

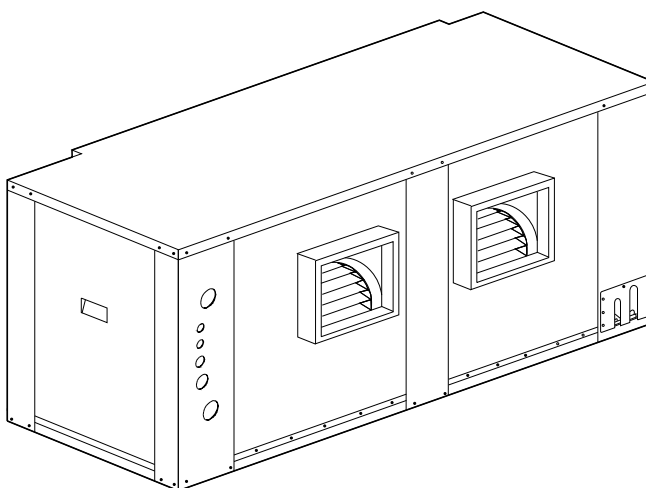

BY JOHNSON CONTROLS

LARGE SPLIT AIR - AIR VITALITY SERIES Air Conditioners VIR 25A to 90A



Quick installation guide

Ref.: N-40310_EN 0411



Index

1	Quick installation guide.....	1
1.1	Safety instructions.....	2
1.2	Icons used in this document.....	2
1.3	Instructions for storage, transport, loading and unloading of the unit.....	3
1.3.1	Inspection.....	3
1.3.2	Disposal of packaging.....	3
1.3.3	Disposal of the unit.....	3
1.3.4	Handling.....	4
1.4	Indoor and outdoor unit combinations.....	5
1.5	Measurements, clearances and accesses.....	6
1.5.1	General dimensions.....	6
1.5.2	Clearances.....	10
1.6	Cooling layout.....	10
1.7	Instructions for installation and connection of the unit.....	10
1.7.1	Characteristics of the location.....	10
1.7.2	Fixture of the indoor unit to the ceiling.....	11
1.7.3	Air ducts.....	12
1.7.4	Drain connections.....	13
1.7.5	Unit interconnection.....	14
1.7.6	Preparation and connecting to the various utilities.....	19
1.7.7	Safety and equipment protection systems.....	24
1.7.8	Instructions for starting up the unit.....	24
1.8	Unit sound power spectrum indication.....	25
2	Unit installation data.....	26
2.1	Unit installation data.....	27
2.2	List of tests for unit start-up.....	27
2.3	Start-up Data.....	28

1

Quick installation guide

1.1 Safety instructions

This document contains the necessary information for the safe and efficient transportation, assembly and installation of the air conditioning unit. This guarantees the condition of the unit and its operating safety.

Only an authorised company may assemble the air conditioning unit.



ATTENTION

Only authorised companies with the appropriate technical resources and suitably trained personnel may install the air conditioning unit.



CAUTION

The specialists responsible for installing the air conditioning unit must make sure they have all of the information and knowledge required to correctly install, test and deliver the unit. Johnson Controls Inc. shall not be considered responsible for any damage caused by installation of the unit that is not consistent with that described in this document or others specifically provided with the unit.

During regular equipment installation, the fitter must pay special attention to certain situations in order to prevent injuries or damage to the unit.

Situations that could jeopardise the safety of the fitter or that of others nearby or that could put the unit itself at risk are clearly indicated in this manual.

A series of special symbols are used to clearly identify these situations.

Pay careful attention to these symbols and to the messages following them, as your safety and the safety of others depends on it.

1.2 Icons used in this document



DANGER

- *The text following this symbol contains information and instructions relating directly to your safety and physical wellbeing.*
- *Not taking these instructions into account could lead to serious, very serious or even fatal injuries to you and others in the proximities of the unit.*

Information can also be found on safe procedures during unit handling. This will help reduce the risk of accidents.



CAUTION

- *The text following this symbol contains information and instructions relating directly to your safety and physical wellbeing.*
- *Not taking these instructions into account could lead to minor injuries to you and others in the proximities of the unit.*
- *Not taking these instructions into account could lead to unit damage.*

Information can also be found on safe procedures during unit handling. This will help reduce the risk of accidents.



NOTE

- *The text following this symbol contains information or instructions that may be of use or that is worthy of a more thorough explanation.*
- *Instructions regarding inspections to be made on unit parts or systems may also be included.*

1.3 Instructions for storage, transport, loading and unloading of the unit



CAUTION

Outdoor units must be moved and stored vertically to prevent oil from leaking from the compressor.

Delivery inspection

The unit should be carefully inspected for visible damage or abnormalities as soon as it is received.

Any abnormalities or damage to the unit should be communicated to both the transportation and insurance company in writing.

Storage instructions

The unit should be stored in a place suitable to the purpose (warehouse or similar), protected from the weather, water, humidity and dust.

Cover the unit with a canvas of a suitable size.

The unit should be appropriately protected from knocks and dust, ensuring the protective parts it was supplied with remain in place. Where these are not in place, establish the necessary protections and/or barriers to keep vehicles or fork-lift trucks away.

Transport, loading and unloading of the unit

The units should only be handled by personnel from the company responsible for their installation.

Transport of the unit should be in such a manner that no damage is caused by faulty or inadequate mooring to the bed or body of the vehicle.

Where necessary, protect all of the edges of the unit against knocks and scratches and moor it to the bed or body of the vehicle using suitable textile belts or slings to keep it perfectly still.

Loading and unloading the unit from a truck or trailer should be on flat, solid ground using an appropriate crane with sufficient capacity.

1.3.1 Inspection

Upon reception, inspect the goods and notify the carrier and the insurance company, in writing, of any possible damage during transportation.

1.3.2 Disposal of packaging

The packaging is recyclable. Dispose of it in the appropriate place or take it to an appropriate collection centre. Respect the regulations in force for this type of waste in the country where the unit is being installed.

Packaging remains must be correctly disposed of. Improper disposal of packaging generates environmental problems that affect human life.

1.3.3 Disposal of the unit

When removing the unit, the components must be ecologically recovered. The cooling circuit is full of coolant that must be extracted and delivered to the gas manufacturer for recycling.



ATTENTION

The refrigerant gas contains greenhouse-effect fluorinated gas covered by the Kyoto protocol.

Please see the specifications plate for type of gas and quantity per system.

GWP (Global Warming Potential): 2088

There will be oil left in the hermetic compressor, therefore it must be delivered with the circuit sealed.

1 Quick installation guide

1.3 Instructions for storage, transport, loading and unloading of the unit

The air conditioner shall be deposited in the area established by local authorities, to facilitate its selective recovery.

1.3.4 Handling

The unit must be moved using the metal rails provided for its installation and transport.

1.4 Indoor and outdoor unit combinations

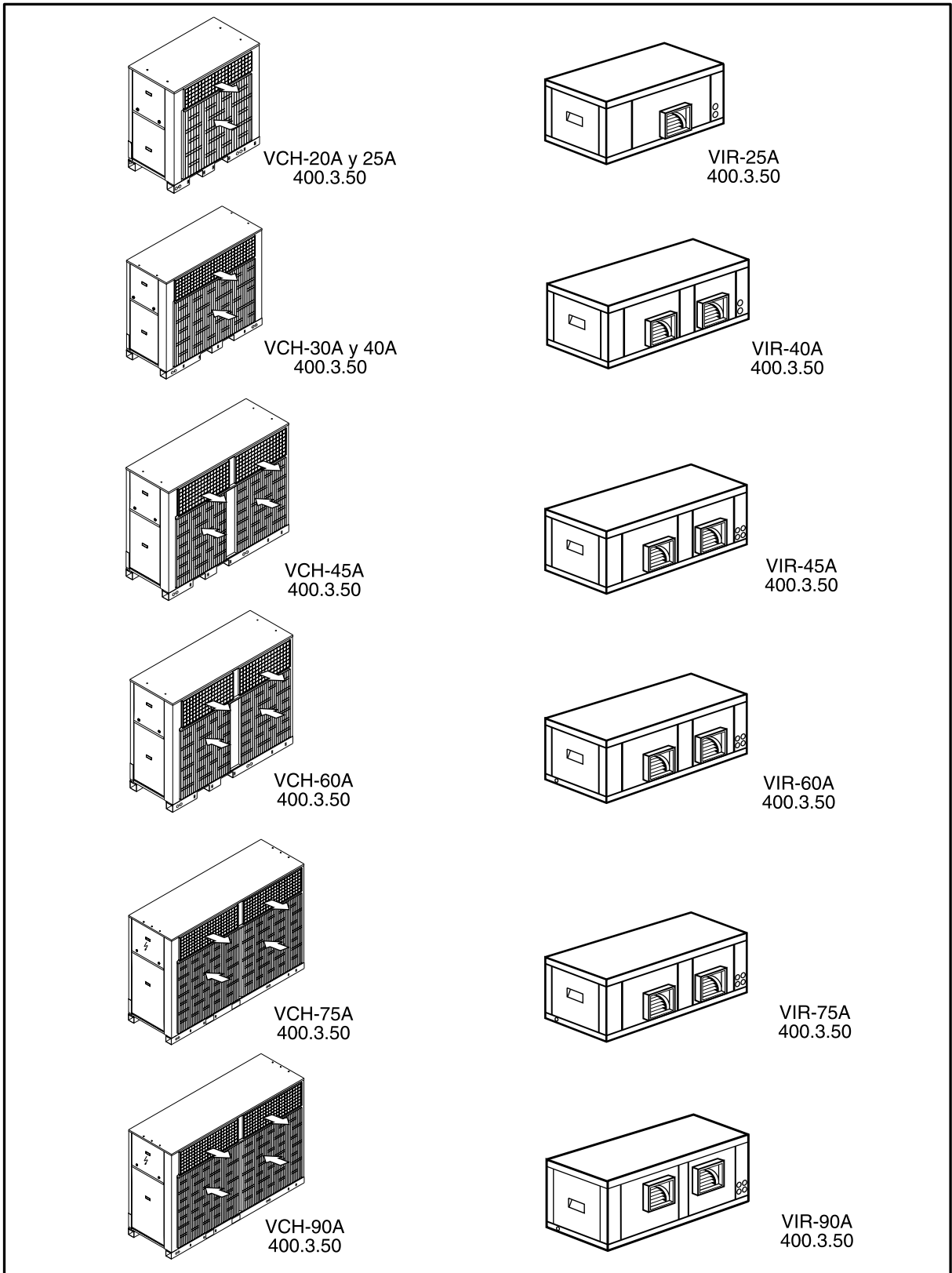

1.5 Measurements, clearances and accesses

1.5.1 General dimensions

General dimensions, VIR 25A

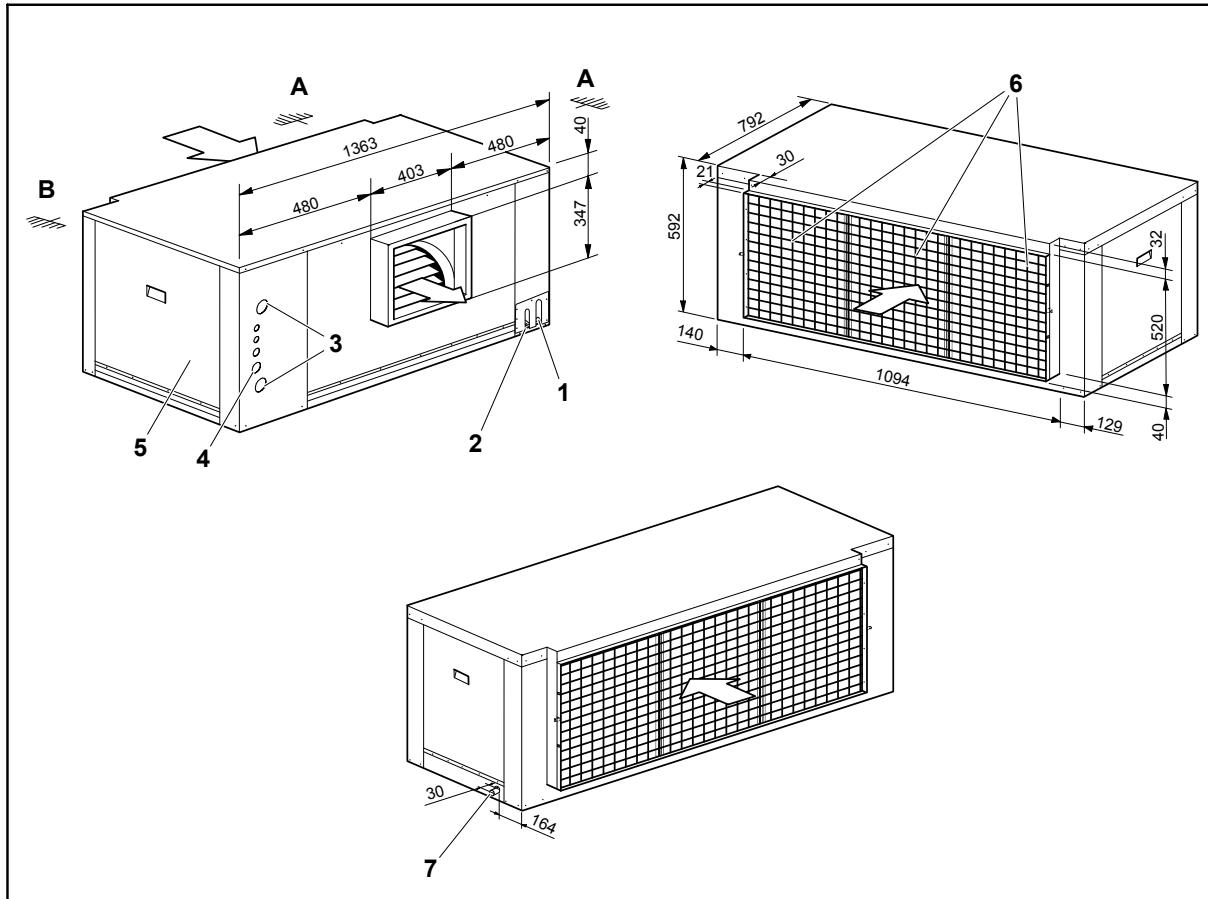

- A. Minimum clearance 600 mm
- B. Minimum clearance 800 mm
- 1. Gas connection 1 1/8"
- 2. Liquid connection 1/2"
- 3. Hot water coil accessory connections
- 4. Electrical connections
- 5. Motor access panel
- 6. Filters
- 7. Drain pipe (outer diameter 28.5 mm)



NOTE

Measurements in mm

General dimensions, VIR 40A

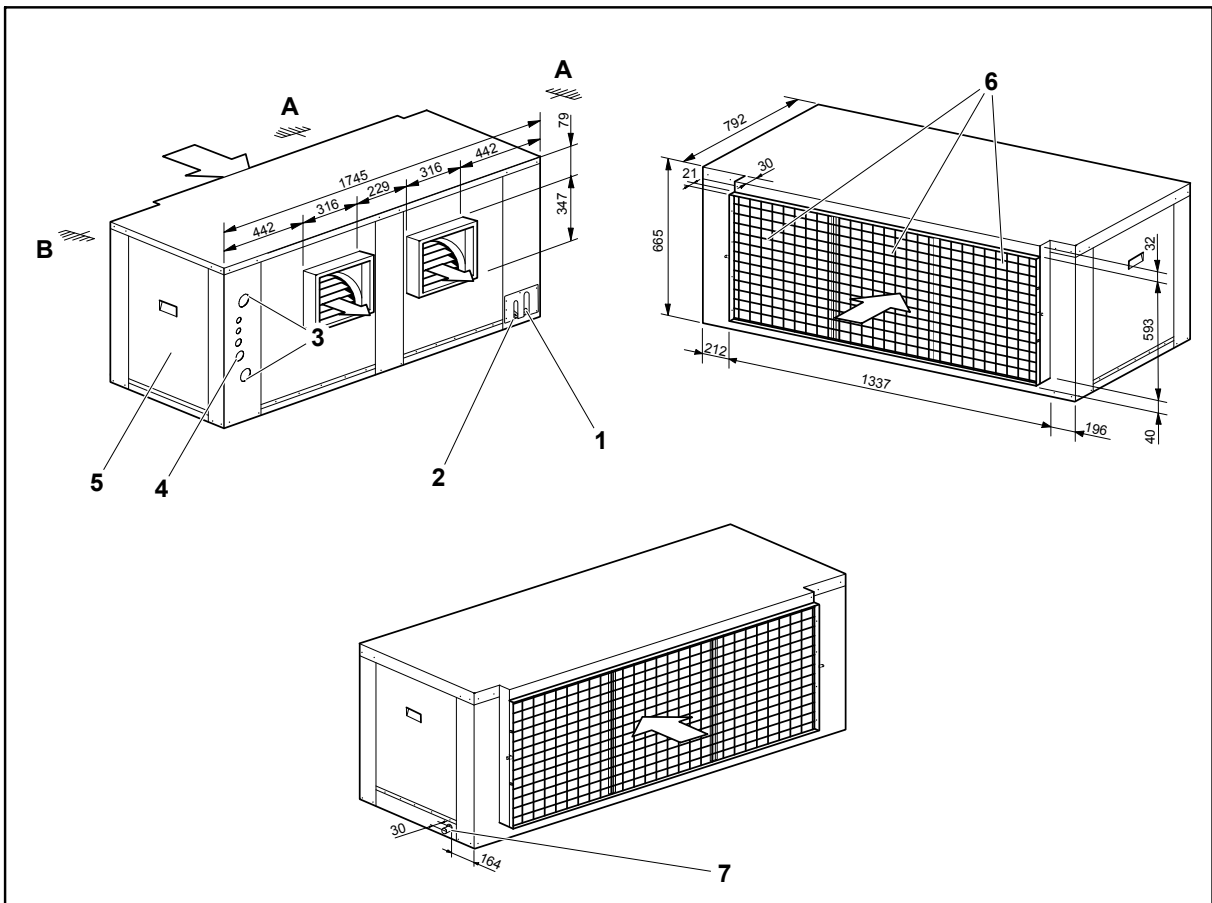

- A. Minimum clearance 600 mm
- B. Minimum clearance 800 mm
- 1. Gas connection 1 1/8"
- 2. Liquid connection 5/8"
- 3. Hot water coil accessory connections
- 4. Electrical connections
- 5. Motor access panel
- 6. Filters
- 7. Drain pipe (outer diameter 28.5 mm)



NOTE
Measurements in mm

General dimensions, VIR 45A and VIR 60A

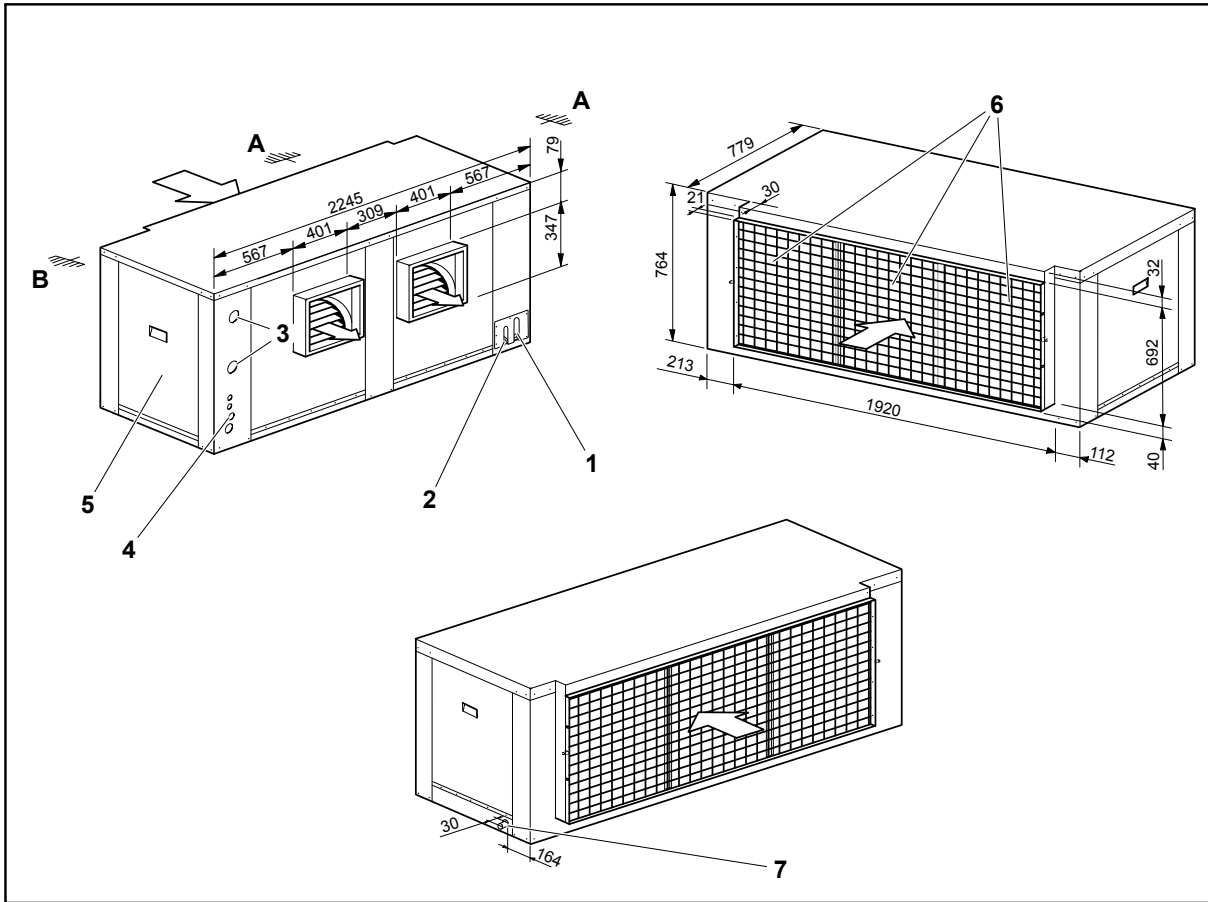

- A. Minimum clearance 600 mm
- B. Minimum clearance 800 mm
- 1. Gas connection 1 1/8" (x2)
- 2. Liquid connection
1/2" (45A) (x2)
5/8" (60A) (x2)
- 3. Hot water coil accessory connections
- 4. Electrical connections
- 5. Motor access panel
- 6. Filters
- 7. Drain pipe (outer diameter 28.5 mm)



NOTE

Measurements in mm

General dimensions, VIR 75A and VIR 90A

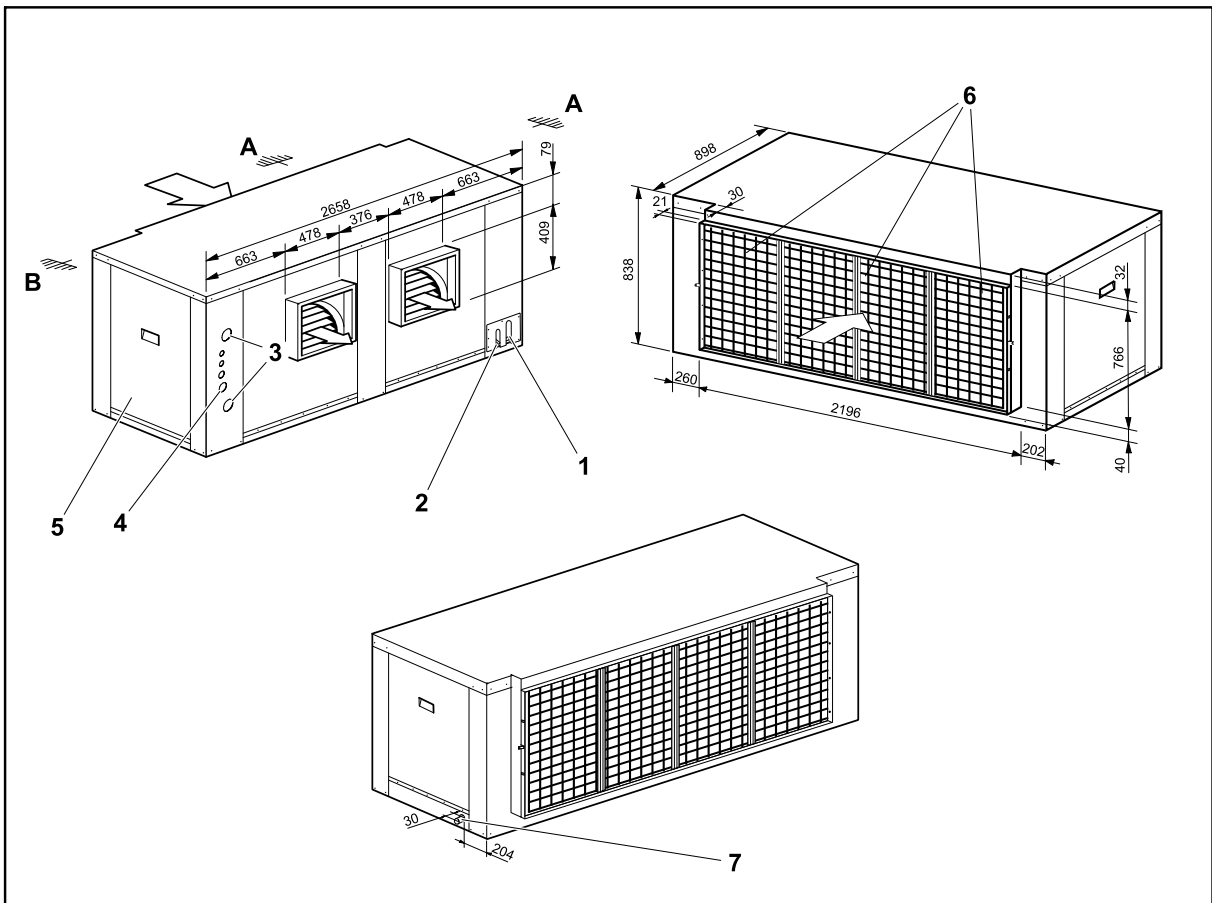

- A. Minimum clearance 600 mm
- B. Minimum clearance 800 mm
- 1. Gas connection 1 1/8" (x2)
- 2. Liquid connection 7/8" (x2)
- 3. Hot water coil accessory connections
- 4. Electrical connections
- 5. Motor access panel
- 6. Filters
- 7. Drain pipe (outer diameter 28.5 mm)



NOTE
Measurements in mm

1.5.2 Clearances

When installing each unit, clearances should be left for:

1. Intake and discharge of air from the outdoor unit.
2. Connection of drain and electricity pipes.
3. Air ducts.
4. Maintenance servicing.
5. Power supply connections.

To operate correctly, all minimum clearances shown on the general dimension diagrams should be respected, with regard to the possible obstruction of air circulation or of the work of an operator.

Minimum technical clearance VIR

A Return air



NOTE

Distances in millimetres

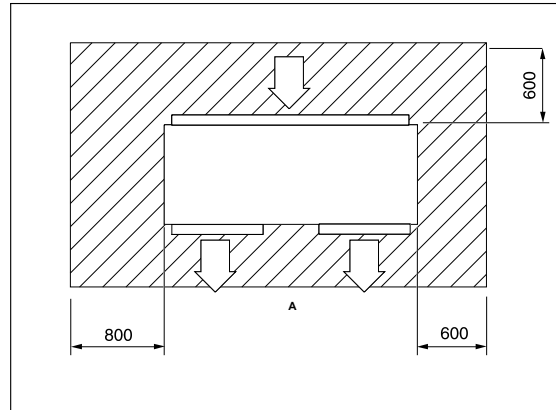

1.6 Cooling layout

The refrigerant pipes must be connected to the units using pipe flaring.

1. Indoor coil
2. Check valve
3. Expansion valve
4. Service valve
5. Suction accumulator
6. Liquid sight glass
7. Expansion valve
8. Check valve
9. Liquid probe
10. Outdoor air probe
11. Outdoor coil
12. 4-way reversing valve.
13. Discharge probe
14. Compressor
15. Suction probe
16. Dehydrator filter

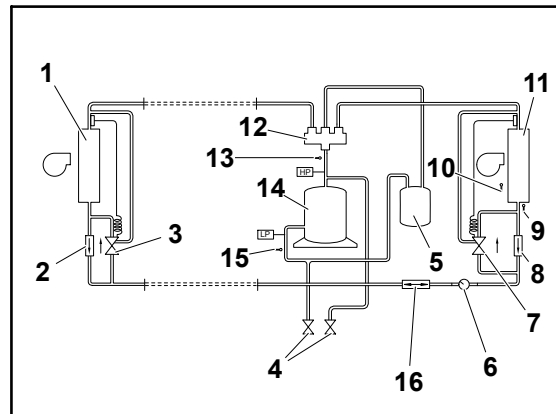

1.7 Instructions for installation and connection of the unit

1.7.1 Characteristics of the location

Location of VIR 25A to 90A indoor units

Locate the indoor unit as close as possible to outdoor walls for easier installation, maintenance and drainage. Make sure the ceiling fastening where the unit is located will withstand its weight.

The unit must be installed completely horizontally or sloping slightly towards the drain side.

Special instructions for locations where there is regular snowfall or with ambient temperatures of close to 0 °C or less

In areas where there is regular or sporadic snowfall, the unit must be elevated above the ground or roof where it is installed. The height should be enough to prevent the unit, the condenser and evaporator air inlets and the access to the unit panels from becoming blocked by accumulated snow.

- A Without anti-snow grilles (low platform)
- B With anti-snow grilles (high platform)

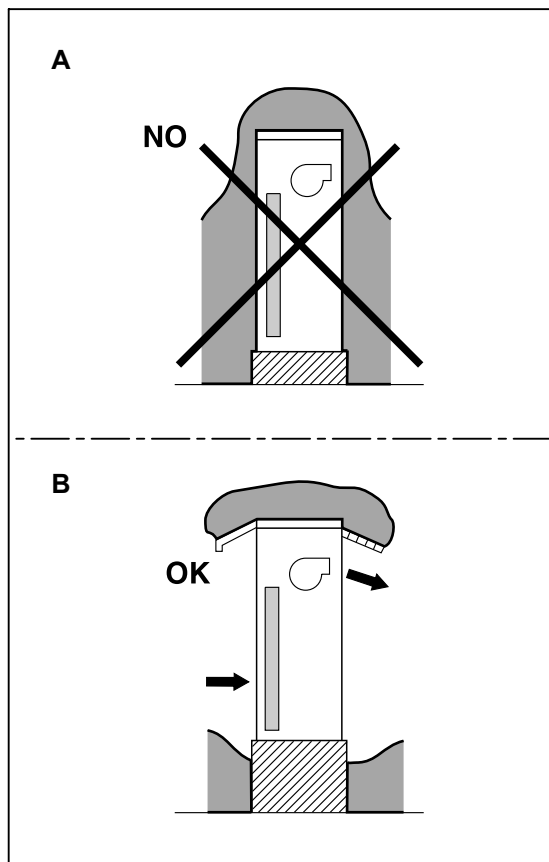

Protection against ice

In areas where the temperature can drop below 0 °C, there must be some kind of additional protection to prevent the water in the condensate drain pipe from freezing.

Use an electric cord resistor in the drain trap as well as in the drain, where applicable.

In heat pumps, also use cord resistors in the outdoor coil tray to prevent any ice from accumulating.

Special instruction for locations with high ambient temperatures

In areas where the ambient temperature is over 43 °C, the unit must not be located in direct sunlight and, therefore a specific cover will be required.

The installation of a special sunshade over the unit must not affect the air flow required by the unit to work correctly. See section *Clearances*, see on page 10.

1.7.2 Fixture of the indoor unit to the ceiling

CAUTION

Make sure the ceiling is strong enough to withstand the weight of the unit.

Before hanging the unit, test the firmness of each suspension bolt installed.

The unit must be attached to the ceiling using the indoor unit supports and the suspension bolts installed.

On attaching it, it must be completely horizontal, leaning slightly towards the drain to avoid any drops of condensation (use a spirit level for levelling).

1.7.3 Air ducts

Characteristics of the facility where the unit will be installed

Air duct installation

The air duct installation where the unit is to be installed must be formed by a closed return duct system. The additional installation of economisers or outdoor air intakes is not excluded.

To reduce operating noise, the supply and return air duct connections on the unit must be made using flexible joints.

The supply and return air duct systems must be designed for the air flow requirements of the installation. The ducts should not be sized based on the supply and return air connection sizes of the unit.

Hatches should be installed on each discharge duct bypass and where access is planned for cleaning and replacement of filters.

Indoor unit air ducts

1. Connect the ducts, isolating them from the appliance using a flexible sleeve preferably made of non-combustible material in order to prevent vibrations from being transmitted from the appliance. Ducts made of flexible materials do not transmit vibrations.
2. A hatch must be located on each discharge duct bypass for correct system balancing.
3. Easy access should be established for cleaning and replacement of the air filters.

1.7.4 Drain connections

Condensates. Insulation and/or protection of ducts

Condensates should be released by means of a specific installation in line with local or national regulations.



NOTE

For further information on this subject, always keep the current regulations for the country where the unit is being installed at hand.

Install a drain trap on the exhaust outlet of the unit -1-. The drain trap must have an access hatch to facilitate emptying and cleaning when necessary.

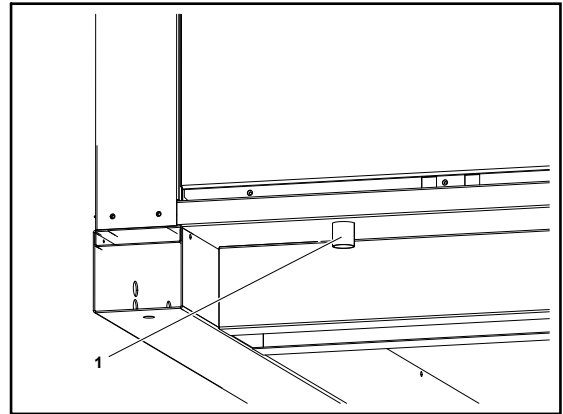

Lay the condensate drain pipe from the connection at the bottom of the unit to a nearby drain.



NOTE

- *The condensate drain pipe should be at a minimum gradient of 2% (2 cm of drop for each metre in length).*
- *The condensate drain pipe must be correctly insulated.*

Drain connections for VIR 25A to 90A indoor units

A pipe must be connected to the indoor unit for condensate drainage. To do so:

- Leave a minimum difference in level of 25 mm between the appliance connection height and the line after the drain trap.

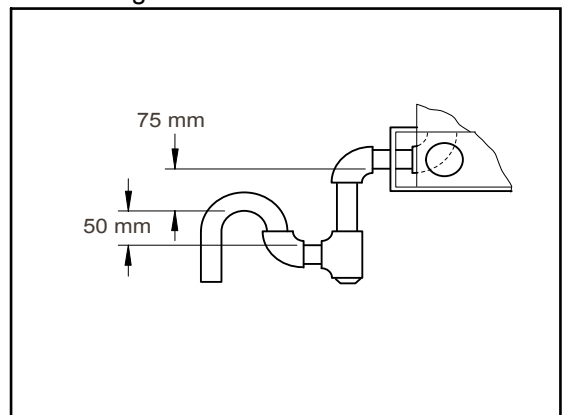

Drain pipe insulation

Insulate the condensate drain pipe to prevent condensation from damaging the surrounding area and the unit.

Check that the water is correctly released.

Protection against ice

In areas where the temperature can reach 0 °C or less, there should be some kind of additional protection to prevent the water contained in the condensate drain pipe from freezing.

An electric heater (wire heater) should be installed in the drain trap and in the condensate drain pipe.

1.7 Instructions for installation and connection of the unit

For units with heat pumps, electric heaters must also be installed in the outdoor coil tray to prevent possible ice accumulation.

1.7.5 Unit interconnection

The installation of the unit includes:

- Unit assembly.
- Refrigerant piping connection.
- Electrical installation of the unit.

In the installation of Split units, the cooling circuit must be completely airtight once assembly is complete to ensure there are no leaks. This provides the maximum performance with the minimum consumption, avoids serious faults in the unit and minimises its effects on the ecosystem.

Unit refrigerant connection

The indoor and outdoor units are connected by refrigerant pipes that form a sealed refrigerant circuit.

The maximum acceptable distances with the standard circuit and tube diameter are those indicated in the graphs and tables of *Refrigerant charge and piping diameter*, see on page 19 (without changing the pipe outlet diameter of the units).

- In the case of horizontal sections measuring over 20 metres in length, the suction line should slant 2% downwards towards the compressor.
- The maximum permitted speed on any section is 15 m/sec.
- With the limitations indicated and where the pipe outlet diameters on the unit are not changed, drain traps are not necessary.
- The liquid must have at least 1 °C subcooling at the expansion valve inlet to avoid the formation of gas in ascending liquid lines before entering the expansion system.
- For connection lines measuring over 25 metres in length, oil must be added (30 g/m of line).

Characteristics of utility provider connections

In general, the different connections required by the unit are made following the shortest route possible. Under no circumstances may any local or national regulations be contravened when performing the preparatory work for service connections.



NOTE

For further information on this subject, always keep the current regulations for the country where the unit is being installed at hand.



CAUTION

- *Before the connection work, possible losses of flow, temperature and voltage drops, etc. that might affect the distances between planned connection points and the unit must be taken into account.*
- *As a result, each connection must be sized accordingly.*

Pipes to be used



CAUTION

Do not leave compressors or dehydrator filters exposed.

Use K or L-type cooling quality copper pipes, S/ASTMB88.

The pipes must be sealed and insulated until they are connected to the units.

Insulation of refrigerant pipes

The pipe insulation must be made of a suitable material with a minimum thickness of 8 mm to avoid condensation and minimum temperature loss due to radiation.

Connection pipe installation



DANGER

Do not carry out work outdoors in the event of adverse weather conditions



CAUTION

Do not use stripping products on Cu - Cu joints.

Use rods with a low melting point and a minimum silver content of 5% when welding the pipes. During this process, there must be a current of dry nitrogen inside the pipe to prevent rust and scale from forming that would damage the welding and, therefore, affect the watertightness of the circuit.



NOTE

- *The connection pipes between units must be as short as possible.*
- *No drain traps are necessary where connecting piping specifications are met.*

Vacuum and dehydrating

The presence of air and dampness in the cooling circuit must be completely eliminated to avoid:

- Damage to the compressor and other parts of the cooling circuit.
- A drop in unit performance.
- Capillary blocking due to freezing.
- Unwanted high pressure increases.
- Increased electricity consumption.

**NOTE**

Prior to the vacuum process, nitrogen gas can be swept through the system to remove most of the dampness and other contaminants in the cooling circuit. The vacuum should be broken on several occasions using nitrogen to ensure dampness is eliminated.

The vacuum is ensure in each cooling circuit as follows:

1. Connect the vacuum pump to the service valves -1- (3/8" taps) on the installation and connect the service manometers to the valve stems (1/4" taps) in the circuit.
2. Open the stopcocks on the service valves and the vacuum pump.
3. Activate the vacuum pump.
4. Vacuum to at least 50 microns.
5. Detect leaks.

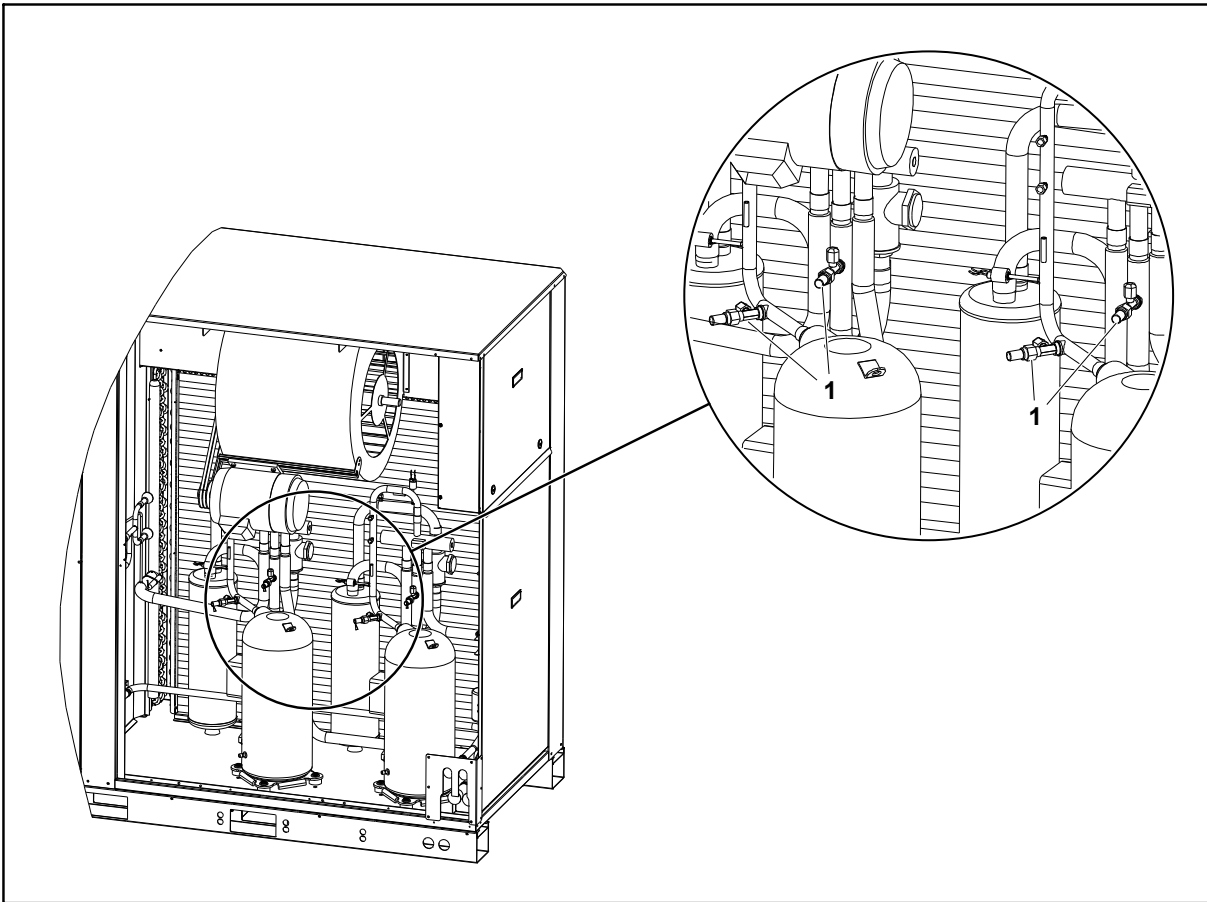
**Refrigerant charge****DANGER**

Due to its characteristics, R-410A refrigerant must only be handled by qualified personnel.

**NOTE**

The unit is not supplied charged

The refrigerant charge is calculated for a 7,5 m length of piping. In installations with longer (or shorter) lengths, add (reduce) refrigerant as indicated in table [Refrigerant charge and piping diameter](#), see on page 19.

In installations with connection piping in excess of 25 m in length, 30 g of oil must be added for every additional metre.

- A Liquid cooling line.
- B Gas cooling line.
- H Vertical distance between units (max. 30 m).
- L Total pipe length (vertical + horizontal sections). Laid and in one direction.
- 1 Outdoor unit.
- 2 Indoor unit.

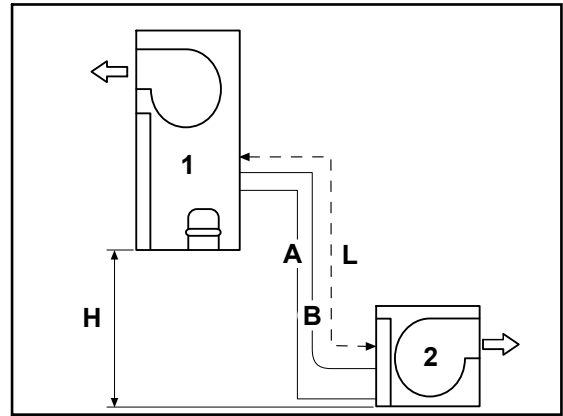

- A Liquid cooling line.
- B Gas cooling line.
- H Vertical distance between units (max. 30 m).
- L Total pipe length (vertical + horizontal sections). Laid and in one direction.
- 1 Outdoor unit.
- 2 Indoor unit.

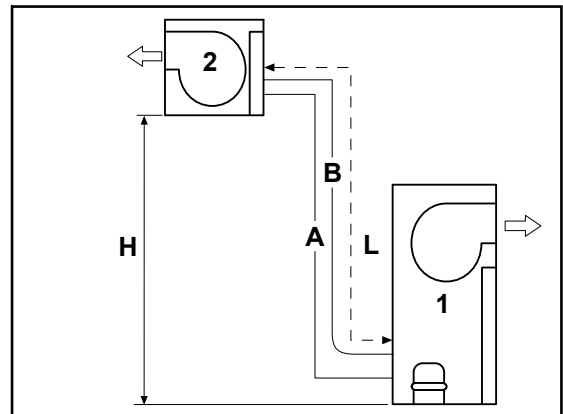

Maximum length L: this is the sum of the lengths of all straight horizontal and vertical sections in one direction, whether they hold liquid or gas.

Maximum equivalent length L_E : this is the sum of the lengths of all straight horizontal and vertical sections in one direction, whether they hold liquid or gas, plus the equivalent length of the accessories, basically elbow joints and bends.

Equivalent length of accessories in metres

Outer pipe diameter	Short elbow joint radius	90° bend (Long radius)
3/8"	0,30	0,20
1/2"	0,40	0,30
5/8"	0,50	0,40
3/4"	0,50	0,40
7/8"	0,60	0,50
1 1/8"	0,70	0,60
1 3/8"	1,00	0,70
1 5/8"	1,20	0,80



NOTE

The 45° elbow joints and bends (used in drain traps, for example) have half the equivalent length of the 90° bends.

Calculation Example

- 1 Outdoor unit.
- 2 Indoor unit.
- 3 1/2" liquid pipe.
- 4 1 1/8" gas pipe.
- A, B, C, D Elbow joints (4)
- E Bends (2)

$$L = 2 + 3 + 3 + 6 + 4 + 7 + 6 = 31$$

31 < 50 is therefore correct

To calculate the equivalent length of the interconnection piping and as for the charge loss calculation, use the data of one of the liquid lines, i.e. 1/2" outer diameter. As can be seen in the diagram, there are four elbow joints with an equivalent length of 0,5 m according to the table and two 0,4 m bends according to the table, to check that the equivalent length of piping does not exceed the accepted maximum:

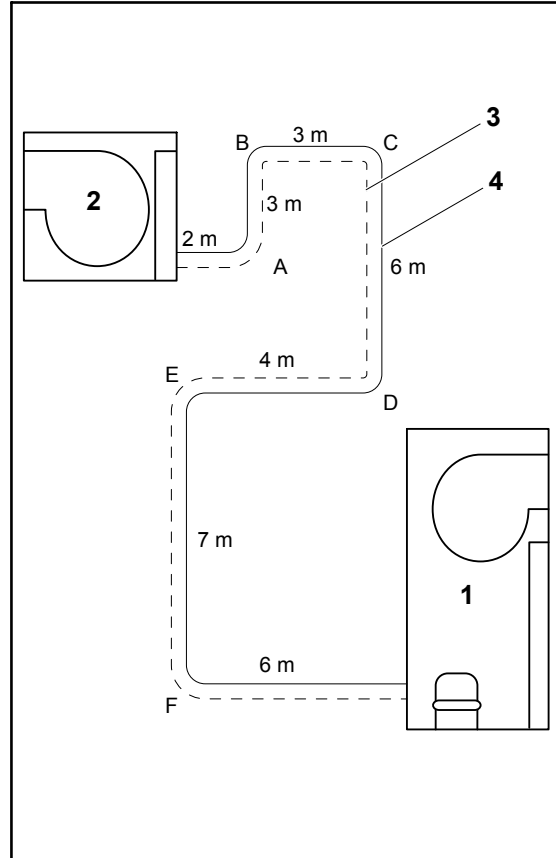

$$L_E = 2 + 3 + 3 + 6 + 4 + 7 + 6 + 4 \cdot (0.5) + 2 \cdot (0.4) = 33.8 \text{ m}$$

33.8 < 60 is therefore correct.

Refrigerant charge and piping diameter

Follow the instructions below to add or charge refrigerant to the cooling pipes:



NOTE

The refrigerant charge must be weight-controlled using scales. The refrigerant must be charged in liquid phase to ensure the components forming it are inserted in the correct proportions.

1. Connect the refrigerant cylinder to the low pressure or gas intake.
2. Open the stopcocks and allow the refrigerant to enter the pipes.



NOTE

Once the refrigerant has been correctly charged, the subcooling temperature (at the expansion valve inlet) must be approximately 1 °C and the overheating temperature between 5 and 10 °C.

Model	Rated charge R-410A (kg)	No. of circuits	Gas line diameter	Liquid line diameter	Additional charge (g/m)	L (m)	L _E (m)
VCH 20A / VIR 25A	8,5	1	1 1/8" (28,5 mm)	1/2" (12,7 mm)	112	50 ¹	60
VCH 25A / VIR 25A	8,5	1	1 1/8" (28,5 mm)	1/2" (12,7 mm)	112	50 ¹	60
VCH 30A / VIR 40A	12	1	1 1/8" (28,5 mm)	5/8" (15,87 mm)	170	50	60
VCH 40A / VIR 40A	12	1	1 1/8" (28,5 mm)	5/8" (15,87 mm)	170	50	60
VCH 45A / VIR 45A	9.5 x 2	2	1 1/8" (28,5 mm)	1/2" (12,7 mm)	112	50	60
VCH 60A / VIR 60A	10.5 x 2	2	1 1/8" (28,5 mm)	5/8" (15,87 mm)	170	50	60
VCH 75A / VIR 75A	15 x 2	2	1 3/8" (35 mm)	7/8" (22 mm)	333	50	60
VCH 90A / VIR 90A	15 x 2	2	1 3/8" (35 mm)	7/8" (22 mm)	333	50	60

L: Maximum length on straight connection pipe sections.

L_E: Maximum equivalent length of unit connection pipes.

¹: As of a total sum of 20 metres in length on straight connection pipe sections (horizontal and vertical) between units, a suction accumulator of at least 7 litres must be fitted on the gas line.

1.7.6 Preparation and connecting to the various utilities

Electricity. Power and control



CAUTION

Loose connection terminals produce overheating of cables and terminals. The unit will work incorrectly and there is a risk of fire.

Power Line

Power must be supplied to the unit through a specific electricity supply line with an exclusive power control and differential breaker, installed in line with national and local regulations.



NOTE

For further information on this subject, always keep the current regulations for the country where the unit is being installed at hand.

Make sure that the electricity supply line has enough capacity to power the unit. Its length, the cable diameter and their protection (cover or jacket) should be appropriate for the unit.

**CAUTION**

The size of the power lines is illustrative and must be corrected based on site conditions and length between units.

Model	Power supply (V.ph.Hz)	Rated power (kW)	Rated current (A)	Start-up current (A)	Power cable cross-section (mm ²)
VIR 25A	400.3.50	0,75	1,8	8	4 x 1.5
VIR 40A	400.3.50	1,5	2,7	17	4 x 1.5
VIR 45A	400.3.50	1,5	3,1	17	4 x 1.5
VIR 60A	400.3.50	2,2	4,6	22	4 x 1.5
VIR 75A	400.3.50	3	4,7	36	4 x 1.5
VIR 90A	400.3.50	4	7	42	4 x 2.5

Use a multimeter to check that the supply voltage remains within the accepted limits.

To install the power cable, loosen the closures -1- by 1/4 turn and remove the electrical board panel.

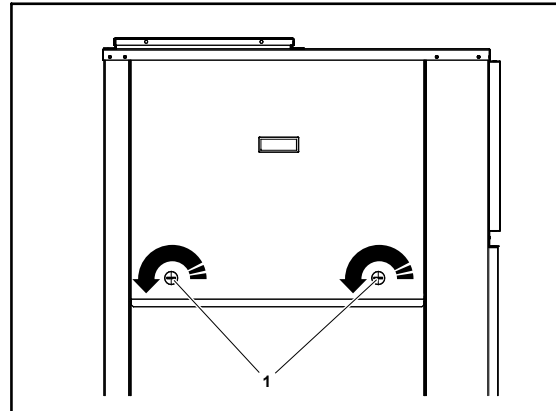

Press the appropriate openings on the edge of the unit -1- until they are released.

Fit packing glands to fit the cable and pull the cable through to the inside of the electrical panel through the grommets in the tray -2-.

Connect the cable to the input connections indicated and firmly tighten the set screws. Also consult the *Wiring diagrams*, see on page 23.



NOTE

The complete wiring diagram for the unit is attached to the inside of the electrical panel.

The electrical panel is fitted with a phase detector to ensure the electrical connection follows the sequence of phases R-S-T. Where the connection does not respect this sequence, the electronic control circuit remains disconnected and the unit will not start.

To correct the phase sequence, change the position of two of the three unit power cables on the input terminals.

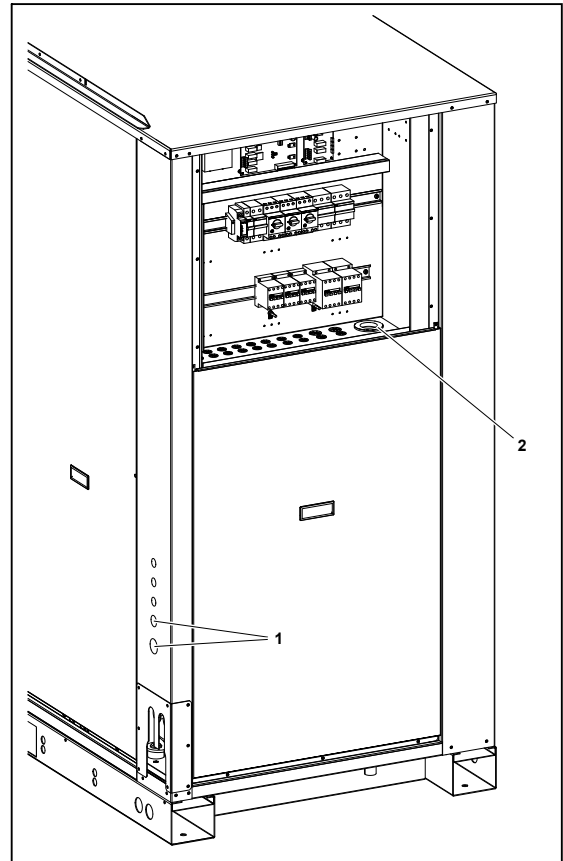

Control Line

Passing the power and control cables through the front of the unit.

Press the appropriate openings on the edge of the unit -1- until they are released.

Fit packing glands to fit the cable and pull the cable through to the inside of the electrical panel through the grommets in the tray -2-.

Connect the cable to the terminals indicated and firmly tighten the set screws. Also consult the wiring diagrams for the unit and *Wiring diagrams*, see on page 23.



NOTE

The complete wiring diagram for the unit is attached to the inside of the electrical panel.

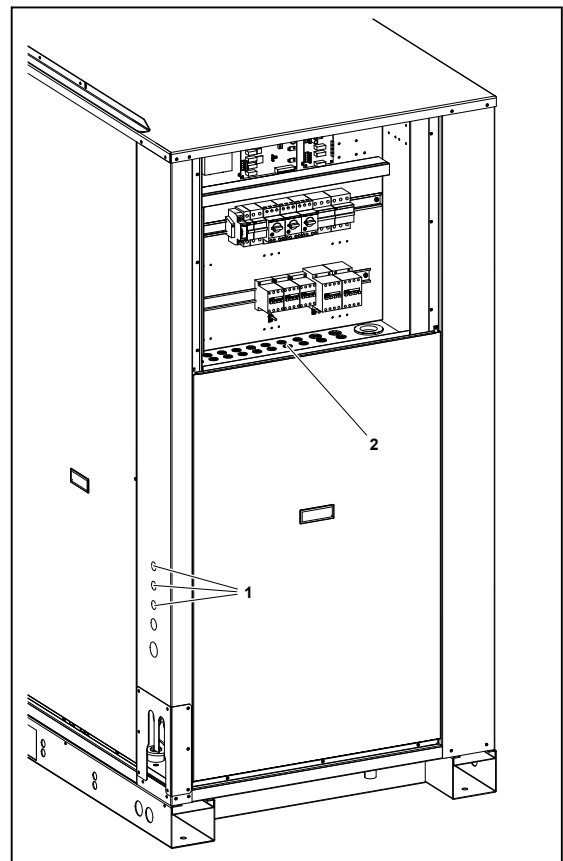

Thermostat Connection

The outdoor unit and the thermostat are connected by means of a 10-pin x 0.22 mm² shielded communication cable. Connect the cable to the terminals indicated and firmly tighten the set screws. Also consult the wiring diagrams for the unit and [Wiring diagrams](#), see on page 23.

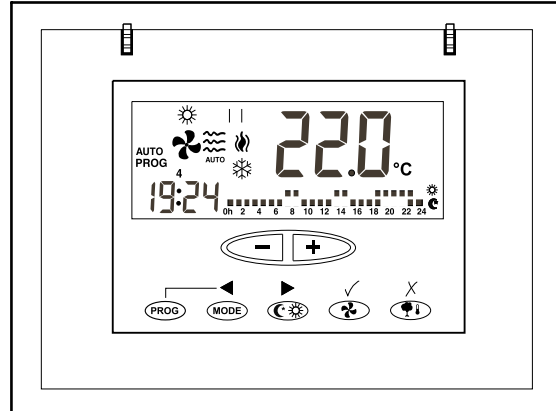

Fan connection for VIR 25A to 90A indoor units

Where the phase sequence is correct (R-S-T) and the fan rotates the wrong way, exchange two phases at the bottom of the fan contactor.

Configuration of the electronic board

The unit is powered for start-up once the accessories have been installed. For the electronic board to respond according to the accessories installed, press the "test" button for around two seconds until the red LED switches off.

Cold only function selection



NOTE

Only use in the event of using the assembly as a cold-only unit with no heat pump

To configure the outdoor unit (VCH) in cold only mode:

- Configure micro-switch (**S1**) no. 5 and no. 4 on the YKN2 Open board to **OFF**.
- Disconnect the power supply to the board to read the new configuration.

Wiring diagrams

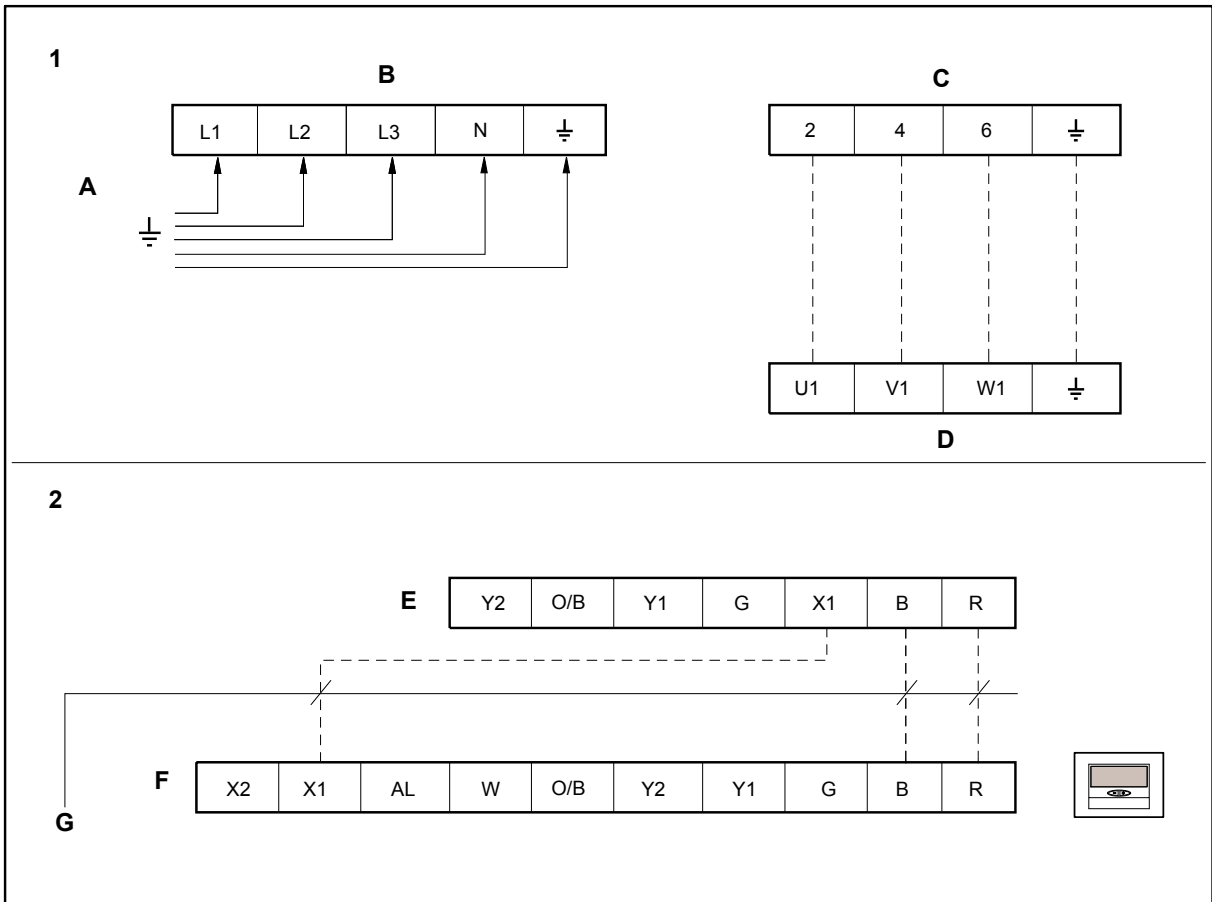

1. Power connection
 2. Thermostat connection
- A. Main power supply (400V / 3 / 50 + N)
- B. Outdoor unit
- C. Contactor
- D. Indoor fan motor (star connection)
- E. Outdoor unit terminal strip (VCH 20A to 90A)
- F. DPC-1 thermostat
- G. 10-pin shielded communications cable x 0.22 mm²

1.7.7 Safety and equipment protection systems

The air conditioning units include an entire series of safety and protection systems intended to provide a high degree of safety for users and maintenance personnel.

Those not expressly authorised to use the air conditioning unit must not handle it or perform repair or maintenance work.

Safety systems

Johnson Controls Inc. manufactures air conditioning units in accordance with EU occupational protection and user safety regulations, provided that the units are used and maintained in line with the instructions and indications given in this document.

Given that the air conditioning unit is installed on the roof of a building or property, users must under no circumstances inspect or adjust the unit themselves. All of inspections or adjustments that may be made by the user are performed using the DPC-1 thermostat.

The air conditioning unit is fitted with electrical protection systems to protect personnel responsible for its regular maintenance and upkeep.

As established by applicable electricity regulations, the electrical system is fitted with electricity surge and current leakage protection system consisting of differential circuit breakers and thermal magnetic switches (not supplied by the manufacturer, must be installed on site).

Under no circumstances is the user of the air conditioning unit exposed to live parts.

Likewise, access to moving parts by unauthorised persons is prevented. This involves placing appropriate safety locks on all of the removable covers on the unit.

Unit protection systems

The refrigerant circuit of the unit is protected against excessively high or low pressure and discharge temperature. It is also protected against repeated cold start-ups caused by the compressor suction probe when the summer cycle is activated.

1.7.8 Instructions for starting up the unit

Electrical checks



DANGER

- *All side panels except for that of the electrical box, must be fitted, closed and secured with their corresponding locks before turning the general switch on the unit.*
- *The unit has a remote control, which means that the fan turbine may start unexpectedly.*



CAUTION

Loose connection terminals produce overheating of cables and terminals. The unit will work incorrectly and there is a risk of fire.

Check that the cables are firmly secured to their connection terminals.



CAUTION

Do not start the unit until all installation work has been completed.

Initial connection of the unit

Once all of the planned accessories are installed, and before starting the unit, its general switch on the installation must be turned on.

Press the "Test" button for two seconds so that the unit recognises the installed accessories. When the recognition process is complete, the red pilot light switches off.

YKN2 Open control board

The unit control software is in the YKN2 Open control board. The control algorithm can be configured or changed by:

- The position of the micro-switches.
- The connection of accessories detected by the board.

The control board indicates the faults detected by means of the red LED V3 on the board or the fault codes indicated on the DPC-1 thermostat.



NOTE

For further information, see the technical information on the YKN2 Open control board.

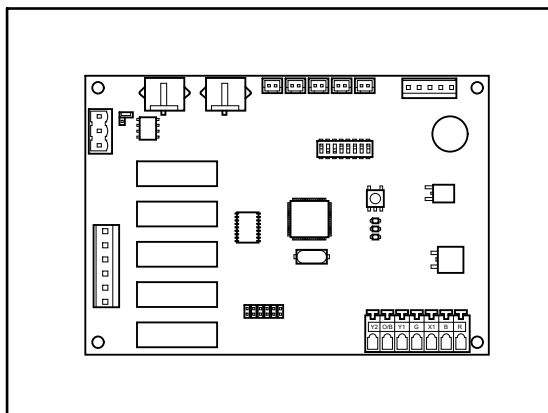

1.8 Unit sound power spectrum indication

Indoor units

Octave band sound spectrum dB(A)	VIR Models					
	25A	40A	45A	60A	75A	90A
125 Hz	63,7	68,6	73,9	75,5	67	68,6
250 Hz	63,7	70,1	73,5	75,1	70	71,6
500 Hz	69,8	73,8	74,5	76,1	73,8	75,4
1000 Hz	70,6	74,8	77,2	78,8	74	75,6
2000 Hz	68,7	75,1	77,1	78,7	74,6	76,2
4000 Hz	64,9	70,5	72,5	74,1	73,7	75,3
8000 Hz	55,8	62,3	65,5	66,6	67,5	69,1
Sound power level dB (A)	75,4	81,3	82,7	84,3	81,5	83,5



NOTE

- *Our reverberating chamber enables us to measure the sound pressure level at 63 Hz and, therefore, the NC (ISO Noise Criteria) will be determined as of 125 Hz.*
- *Where the sound pressure value of 63 Hz is deduced, between 0 and 10 dB will be added to the pressure value at 125 Hz*
- *The data given in this table are sound power values in accordance with ISO EN3743.*

2

Unit installation data

2.1 Unit installation data

Please complete the following data to register the full details of the installation and the start-up inspection.

Complete the blank fields or mark the appropriate box, as applicable.

2.2 List of tests for unit start-up

Please complete the following forms to register the full details of the installation and the start-up inspection.

Complete the blank fields or mark the appropriate box, as applicable.

Company performing installation:

Company performing installation:	
Installing technician:	
Name / project number:	
Location of the unit:	
Address of the unit location:	
Person in charge of the building or property where the unit is installed:	
Installation work start date:	
Unit model number:	
Unit serial number:	
Plate and version:	
Thermostat, model and version:	

General inspection of the unit

	Visual appearance
	Levelling of the unit
	Check the unit for transport, loading and unloading damage
	Unit installed with sufficient clearance
	Check the circuit for the presence of oil (large coolant leaks).
	Terminals and connections correctly secured in the control panel and accessories
	Air filters installed
	Condensate drain pipe and drain trap installed correctly
	Thermostat and connection cabling installed correctly
	Air duct installation complete and correct
	Accessories and planned options installed (if applicable)

Inspection of the air supply fan

	Drive belt and pulleys aligned and correctly fastened
	Drive belt tension correctly adjusted
	Verification of direction of rotation

Inspection of compressors

	Verification that direction of rotation is correct
--	--

2.3 Start-up Data

Electrical data

	Rating plate	Actual
Power supply	Check specifications in the Installation Manual	
Control voltage		
Fan consumption (A)		
Consumption of condenser fan 1 (A)		
Consumption of condenser fan 2 (A)		
Consumption of compressor 1 (A)		
Consumption of compressor 2 (A)		
Consumption of supply fan (A)		
Electric heater 1 (Optional)		
Electric heater 2 (Optional)		

Cool and heat modes

Coolant circuit. Compressor 1		
Mode	Value	
Subcooling (min. 8 K, max. 18 K)	°C	Liquid pressure: ____ bar
		Liquid temperature: ____ °C
Overheating (min. 4 K, max. 10 K)	°C	Suction pressure: ____ bar
		Suction temperature: ____ °C
	Complete liquid line checked in sight glass	
	Correct oil level checked in sight glass	

Coolant circuit. Compressor 2		
Mode	Value	
Subcooling (min. 8 K, max. 18 K)	°C	Liquid pressure: ____ bar
		Liquid temperature: ____ °C
Overheating (min. 4 K, max. 10 K)	°C	Suction pressure: ____ bar
		Suction temperature: ____ °C
	Complete liquid line checked in sight glass	
	Correct oil level checked in sight glass	

Air flow rate values

	m ³ /h
Design	
Measured	

Air temperature

Mode (cool or heat):	Temperature (°C)
Outdoor air:	
Supply air:	
Return air:	
Indoor air mix (if economiser is fitted):	

Options

Heating mode (hot water coil)	
Air temperature	
Capacity: _____ (kW)	Temperature (°C)
Supply air (at 100 %)	
Return air	

Hydraulic circuit		
	Temperature (°C)	Pressure (bar)
Water inlet		
Water outlet		

Others

Outdoor fan 1	Type or model	
		Surge protection adjusted

Outdoor fan 2	Type or model	
		Surge protection adjusted

Indoor fan	Type or model	
		Surge protection adjusted

Belts	Type or model	
Economiser		Minimum outdoor air setting

