

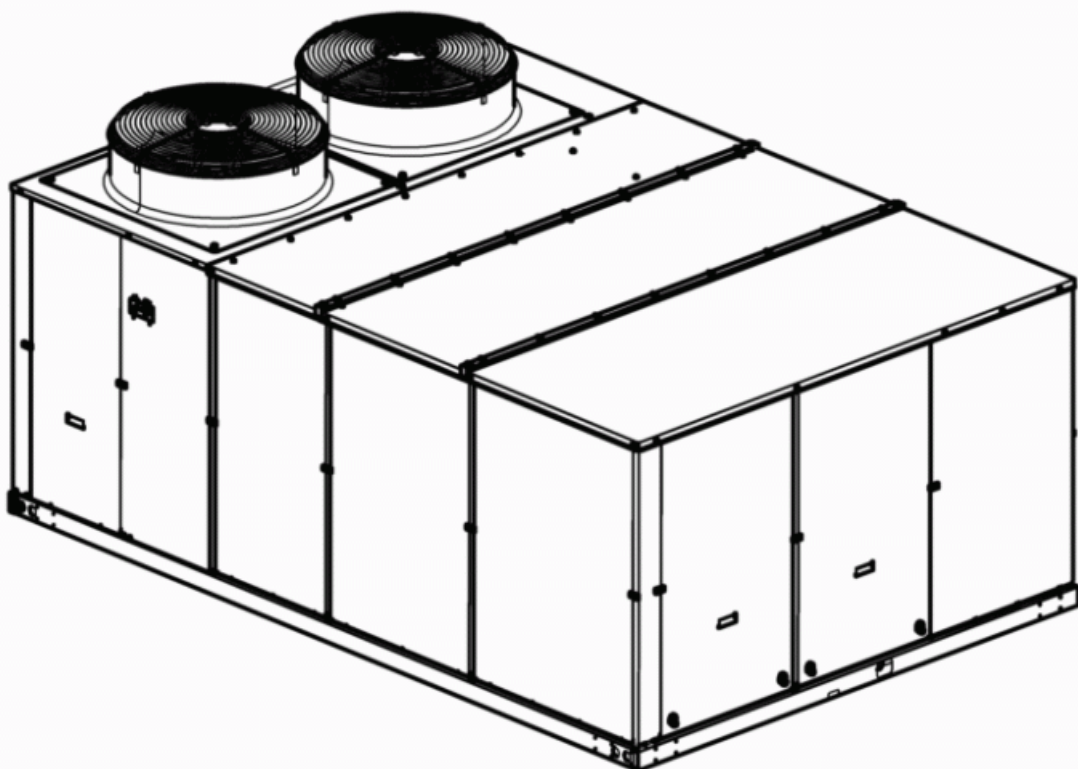

BY JOHNSON CONTROLS

# ACTIVA SERIES ROOF TOP Air Conditioners



**User manual**

**Ref.: N-40318\_EN 0709**



# Index

<b>1</b>	<b>User manual.....</b>	<b>1</b>
<b>1.1</b>	<b>General description of the unit.....</b>	<b>2</b>
1.1.1	Description of the unit.....	2
1.1.2	Service and Maintenance Access.....	4
<b>1.2</b>	<b>Intended use of the unit.....</b>	<b>4</b>
<b>1.3</b>	<b>Description of the unit's main control panel.....</b>	<b>5</b>
<b>1.4</b>	<b>Modes of operation.....</b>	<b>5</b>
1.4.1	ARC Models: air conditioning.....	6
1.4.2	ARG/ARD Models: cooling / heat pump, gas burner heating.....	6
1.4.3	ARG/ARD Models: cooling / heat pump, gas burner heating.....	6
1.4.4	General instructions.....	6
<b>1.5</b>	<b>Operating instructions.....</b>	<b>7</b>
1.5.1	Thermostat connections to the control board.....	7
1.5.2	Thermostat connections.....	8
<b>1.6</b>	<b>Safety and equipment protection systems.....</b>	<b>8</b>
<b>1.7</b>	<b>Placing the unit out of service for a planned stoppage or breakdown.....</b>	<b>9</b>
1.7.1	Placing the unit out of service for planned stoppage.....	9
1.7.2	Placing the unit out of service for seasonal stoppage.....	9
1.7.3	Placing the unit out of service due to a fault.....	9
1.7.4	Fault codes for the air conditioning unit.....	10
1.7.5	Restarting the air conditioning unit in the case of breakdown.....	11
<b>1.8</b>	<b>Regular maintenance activities for which the user is responsible.....</b>	<b>11</b>
1.8.1	Maintenance Schedule.....	11
1.8.2	Maintenance responsibilities of the user.....	11

1

---

# User manual

## 1.1 General description of the unit

### 1.1.1 Description of the unit

The Roof Top ACTIVA model line consists of a series of compact units tested for reliability. Depending on the type of installation, models are available with cooling, heat pump and heating with gas burner. The air intakes and outlets can be configured vertically or horizontally on all models.

Software installed in the YKN2 Open board provides electronic management for the units. The specific configuration of each unit is programmed in this board.

In addition, a wide range of accessories is available to adapt the units to the specific requirements of each application. Roof Top ACTIVA air conditioning units Roof Top ACTIVA series air conditioning units can be used in extreme weather conditions.

The entire range of units uses environment-friendly, recyclable R-410A gas refrigerant.

#### Features of the structure

The structure of the unit is designed to drain rainwater and condensation to its exterior. The roof surface has special contours in the evaporator area to prevent the accumulation of puddles of water. All along its perimeter it also has a drain to prevent the water accumulated on the top panel from flowing down the sides.

#### Construction features and anti-corrosion protection

All metal parts of the structure are made of galvanised aluminium steel plate.

The outdoor parts are treated with an oven-polymerised polyester paint (RAL9002), guaranteeing a quality finish that lasts for many years. (800 H.N.S. in compliance with DIN 50021).

There are options like coils with Blue-Fin type fins or copper fins in order to adapt the product perfectly to its environment.

#### Thermal/Acoustic Insulation

The inside of the evaporator area and the heating supply/accessory area are fully insulated.

The 10 mm thick insulation protects the outside surface with a sheet of reinforced aluminium with M1 fire resistance rating in line with UNE 23727. This aluminium surface keeps friction for air passage to a minimum and is easy to clean.

#### Unit base

The base of the unit is made with fixed beams that provide a solid foundation. Openings on the front of these beams can be used to attach a crane for hoisting the unit into position during the installation process.

The beams also have openings on the bottom to place the unit on dampers, if required.

#### Duct Connection

The entire line of units is prepared for connecting air supply and return ducts for downward or sideways flow.

In the case of units to be installed with sideways ducts, an additional panel kit is required to replace the original supply and return panels.

#### Air flow provided by the unit

In order to meet the precise conditions of flow and static air pressure needed in each installation, all units include air supply fans with belt and adjustable diameter pulleys in the motor.

### **Air filters**

All units have standard filters with metal frame and average filtering of 48 mm available in zig-zag. Gravitometric efficiency is 90%, G4, complying with EN779 and fire resistance is F1 in accordance with DIN 53438.

Optionally, high opacimetric efficiency filters, classes F6 and F7 are available according to EN779. These filters are easily installed behind the standard filters.

### **Cooling circuit**

The Rooftop ACTIVA units have 1 cooling circuit equipped with 2 compressors placed in tandem. This makes for better performance when the unit is not running at full capacity, which is usually the case. It also improves unit operations at extreme temperatures, as it does not jam and continues operating at partial capacity, using the entire surface of the exchangers.

Based on the accumulated operating hours of each compressor, a control circuit determines the order of operation, thus lengthening their working life.

### **Compressors**

Vertical hermetic scroll-type compressor, with internal motor protection and standard outside case resistance.

The compressors have dampers to reduce operating noise and vibrations.

### **Cooling circuit protection**

All cooling circuits are supplied as standard with high and low-pressure switches, dehydrator filter on the liquid line, discharge temperature cut-out switch, liquid sight glasses and temperature sensors for supply air, suction liquid and outdoor air.

### **Service connections**

In order to make the connections with a minimum amount of work, electrical and control cables can be pulled into the unit at the side or through the base.

### **Electrical panel**

The unit's electrical panel meets EN60204-1 and EN60439-1 standards. The main switch with a drive lever is a standard component on all units. The electric motors are protected with specific thermal magnetic switches and motor protection relays.

The unit is fitted with a sequence and phase fault sensor: where a non R-S-T phase sequence is detected or where, once the unit is running, there is a phase fault, the sensor will disconnect the power supply to the main board of the unit, preventing it from starting.

### **YKN2 Open Control Circuit**

This is a 24 V control circuit. It can operate with the optional DPC-1 thermostat (communication) as well as a 24 V thermostat with control signals (Y1, G, O/B, W).

The YKtool system analyser can be used to simplify commissioning and placement and to solve any installation or operational faults.

### **Gas Burner (RAG/RAD Units)**

All of the models that operate with gas have the same two capacity control stages. The burner group consists of an aluminised steel pipe exchanger, adjustable gas valve, electronic starter control, mechanical ventilation and all the safety controls necessary to satisfy EC standards.

The gas supply pipe is directed to the heating compartment through the front panel of the unit. The unit provided is complete and ready to be hooked up to a natural gas connection at 20 mbar (2ND-H, G20). By making certain adjustments, it can also be easily converted to use with the 2ND-L G25 natural gas family. In addition, it is possible to adapt it to operate with LPG (Liquefied Petroleum Gas propane G31) using a specific conversion kit for the adaptation.

### Noise emissions

All units operate with extremely low noise emission levels. The compressors have anti-vibration mounts as well as vertical discharge fans that direct noise upwards, away from surrounding buildings and property.

### 1.1.2 Service and Maintenance Access

The unit access panels have 1/4 turn closures and levers offering fast secure access to all components that require service or maintenance.

Access to the control circuit is independent to the cooling system of the unit.

The unit is fitted with connections for specific manometers for easier reading of cooling circuit pressures. These connections can be accessed from outside and no panel has to be opened or removed for this task.

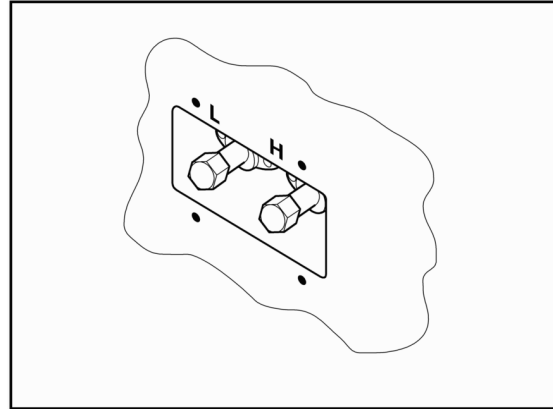

## 1.2 Intended use of the unit

The Roof Top ACTIVA series of units is exclusively designed for the air conditioning of buildings and properties.

The unit uses a cooling system, heat pump, gas burners and/or electrical heat for support, depending on the version of same. It forces air current to circulates through ducts, enabling adjustment of the temperature of the building or property where it is installed. In addition the air conditioning unit has a start and adjustment mechanism (a thermostat or similar) to manage its operations.

The unit should only be used for the purposes for which it was designed and built. Johnson Controls Inc. shall not be considered responsible for any damage caused by inappropriate use or maintenance of the unit, that is anything inconsistent with that described in this document or others specially provided with the unit.

Any use other than air conditioning will be considered inconsistent.

## 1.3 Description of the unit's main control panel

- 1. YKN2 Open circuit board
- 2. Accessory circuit board
- T1. 230 V / 24 V Transformer
- F1. Compressor 1 circuit breaker
- F2. Compressor 2 circuit breaker
- F3. Circuit breaker for supply air fan
- F4. Circuit breaker for outdoor fan
- FC. Sequence and phase fault sensor
- F9. Circuit breaker for compressor case and 230 V transformer heating resistors
- F10. 24 V transformer
- KM1. Compressor 1 motor contactor
- KM2. Compressor 2 motor contactor
- KM3. Supply air draft blower contactor
- KM4. Outdoor draft blower contactor
- Q3. Main switch for the unit

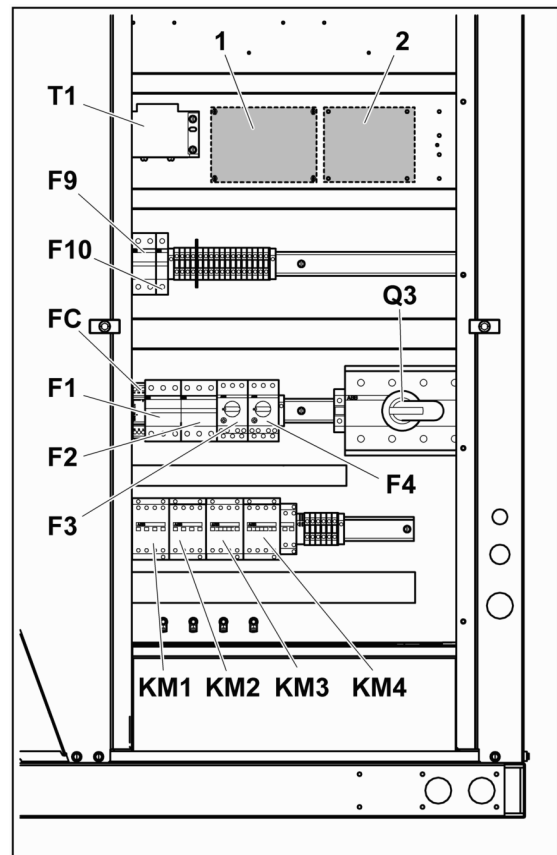

The main control panel is found on the unit itself and is protected from the outside by a removable metal panel.

Given that the air conditioning unit is installed on the roof of a building or property, users must under no circumstances inspect or adjust the unit themselves. All of inspections or adjustments that may be made by the user are performed using the DPC-1 thermostat.

If the air conditioning unit is faulty, its self-diagnostics system will identify the source and the pilot light -1- on the display of the DPC-1 thermostat will switch on. The display will also show a two-digit number on the lower left 2 indicating the effected component. See [Placing the unit out of service for a planned stoppage or breakdown.](#) , see on page 9 .

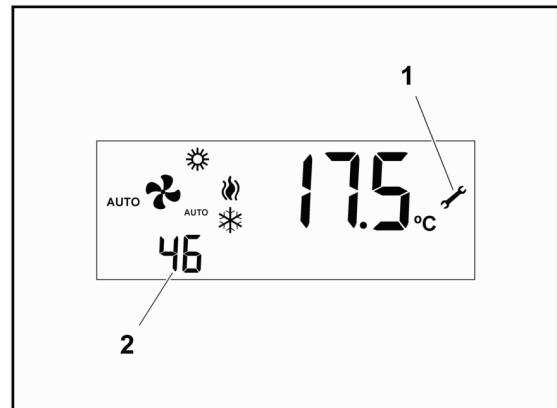

If the thermostat display keeps showing the pilot light -1- and any fault code or if the air conditioner does not start, contact a Johnson Controls Inc. Authorised Technical Assistance Service.

## 1.4 Modes of operation

The Roof Top ACTIVA range of air conditioning units includes different models: the operating mode for each one varies depending on the specific model.

### 1.4.1 ARC Models: air conditioning

The ARC model circulates refrigerant gas (R-410A) through a cooling circuit driven by two compressors mounted in tandem. The propelled gas circulates through an evaporator coil where it absorbs ambient heat and evaporates. To liquefy the evaporated gas, it is then circulated through a condenser coil where it releases the previously absorbed heat into the atmosphere.

To favour the evaporation and condensation of the gas refrigerant, the unit has supply and intake fans that force the air through each of the coils. In the case of the evaporator, the fan pushes air to the inside of the building or property through previously-installed distribution ducts. In the case of the condenser, the fan pushes fresh air through the coil and then sends it back outdoors.

A series of filters remove dust particles and pollen, etc. from the air sent inside the building or property.

### 1.4.2 ARG/ARD Models: cooling / heat pump, gas burner heating

The ARG/ARD models join an additional heating and air supply system to their respective cooling circuits.

In this case, the air inbound to the building or property circulates in a chamber where a tube exchanger is located. High temperature from the gas burner circulates inside the pipes.

### 1.4.3 ARG/ARD Models: cooling / heat pump, gas burner heating

The ARG/ARD models join an additional heating and air supply system to their respective cooling circuits.

In this case, the air inbound to the building or property circulates in a chamber where a tube exchanger is located. High temperature from the gas burner circulates inside the pipes.

### 1.4.4 General instructions



#### CAUTION

- *Always keep the electrical power supply connected to the unit.*
- *Only disconnect the unit if it is not to be used for a long period of time.*
- *When preparing for seasonal use, connect the unit to the electricity supply at least 8 hours before starting it.*

Connect the air conditioning unit to the electricity supply at least 8 hours before starting it. To do so, use the general switch -Q3-.

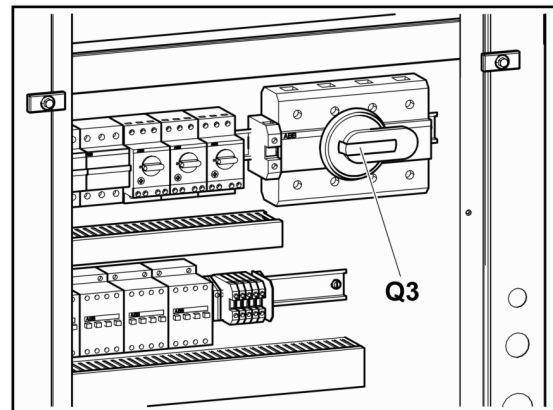



False start the compressors (connect them just long enough to make a few turns). To do so, use contactors -KM1- and -KM2-.

Wait for 5 to 7 minutes and repeat the false start.

Wait another 5 to 7 minutes and perform a last false start.

Then switch the compressors to full working order.

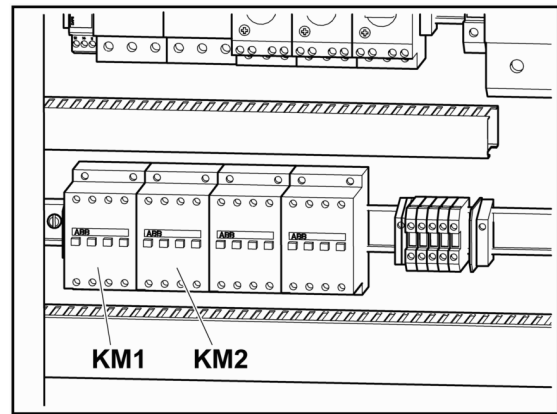

## 1.5 Operating instructions

A thermostat is used for starting and managing the air conditioning unit and for adjusting the temperature of the supply air.

Through this thermostat, the operating programme determines when to automatically start the air conditioning unit. The performance of the different unit components is also determined by the operating programme.

Refer to the documentation for the DPC-1 programmable digital thermostat with communication or the documentation for the thermostat installed with the unit for more detail on start-up and regulation mechanisms.

### 1.5.1 Thermostat connections to the control board

A. Thermostat connection board.

#### Board connection terminals

- X1. To terminal X1 of the DPC-1 thermostat.
- B. White To terminal B of the DPC-1 thermostat.
- R. Red. To terminal R of the DPC-1 thermostat.
- W. —
- O/B —
- Y1 —

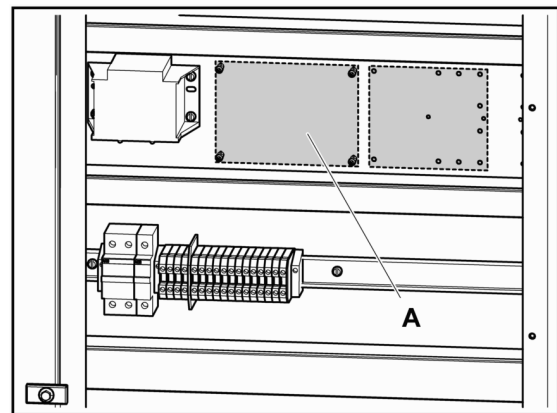

## 1.5.2 Thermostat connections

1. Yellow cable.
  2. Red cable.
  3. White cable.
- A. Shielded cable, 2 x 0,5 mm<sup>2</sup>. Maximum length: 100 m.
  - B. Shielded cable, 10 x 0.22 mm<sup>2</sup>. Maximum length: 100 m.

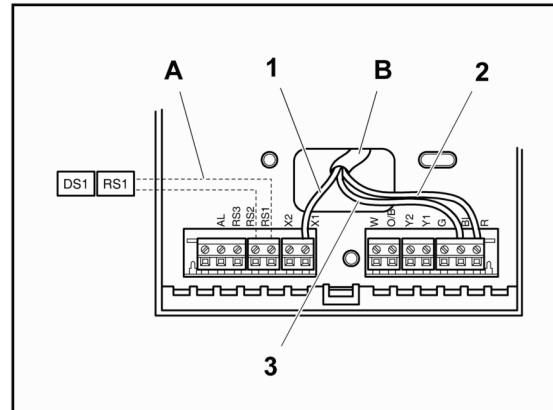

## 1.6 Safety and equipment protection systems

The Roof Top ACTIVA range of air conditioning units includes an entire series of safety and protection systems intended to provide a high degree of safety for users and maintenance personnel.

Those not expressly authorised to use the air conditioning unit must not handle it or perform repair or maintenance work.

### Safety systems

Johnson Controls Inc. manufactures air conditioning units in accordance with EU occupational protection and user safety regulations, provided that the units are used and maintained in line with the instructions and indications given in this document.

Given that the air conditioning unit is installed on the roof of a building or property, users must under no circumstances inspect or adjust the unit themselves. All of inspections or adjustments that may be made by the user are performed using the DPC-1 thermostat.

The air conditioning unit is fitted with electrical protection systems to protect personnel responsible for its regular maintenance and upkeep.

As established by applicable electricity regulations, the electrical system is fitted with electricity surge and current leakage protection system consisting of differential circuit breakers and thermal magnetic switches (not supplied by the manufacturer, must be installed on site).

Under no circumstances is the user of the air conditioning unit exposed to live parts.

Likewise, access to moving parts by unauthorised persons is prevented. This involves placing appropriate safety locks on all of the removable covers on the unit.

### Unit protection systems

The refrigerant circuit of the unit is protected against excessively high or low pressure and discharge temperature. It is also protected against repeated cold start-ups caused by the compressor intake sensor when the summer cycle is activated.

## 1.7 Placing the unit out of service for a planned stoppage or breakdown.

### 1.7.1 Placing the unit out of service for planned stoppage

To stop the air conditioning unit using the DPC-1 thermostat, press the **MODE, -1-** key repeatedly until the following appears: **OFF, -2-**.

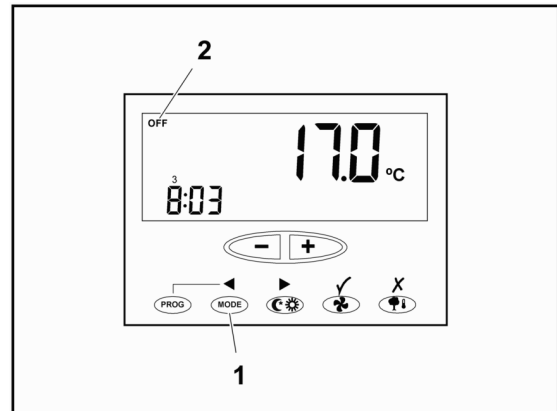

### 1.7.2 Placing the unit out of service for seasonal stoppage

The power supply to the unit must be disconnected when placing the air conditioning unit out of service for long periods of time (seasonal stoppage).

To do so, the differential circuit breaker and thermal magnetic switch on the unit power supply must be disconnected.



#### CAUTION

- *Always keep the electrical power supply connected to the unit.*
- *Only disconnect the unit if it is not to be used for a long period of time.*
- *When preparing for seasonal use, connect the unit to the electricity supply at least 8 hours before starting it.*

### 1.7.3 Placing the unit out of service due to a fault

If the air conditioning unit is faulty, its self-diagnostics system will identify the source and the pilot light -1- on the display of the DPC-1 thermostat will switch on. The display will also show a two-digit number on the lower left -2- indicating the effected component.

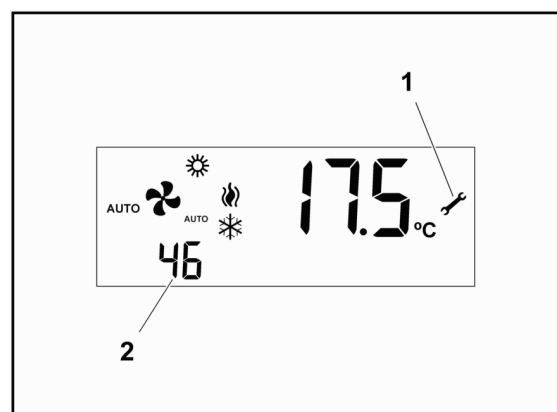

## 1.7 Placing the unit out of service for a planned stoppage or breakdown.

### 1.7.4 Fault codes for the air conditioning unit

Code	Description
11 / 21 / 31	Discharge temperature exceeded
12 / 22 / 32	High-pressure switch, outdoor fan thermal switch or compressor module thermal switch (depending on model)
13 / 23 / 33	Low-pressure switch
14	Indoor fan thermal switch
15 / 25 / 35	Repeated cold start-up or suction temperature < -25 °C
41	Gas control 1 or resistor 1 fault
42	Gas control 2 or resistor 2 fault
43	Resistor stage 3 fault
44	Resistor stage 4 fault
45	Fault in economiser or hot water coil (outdoor supply, water return sensor)
46	Smoke detector, high temperature, or supply temperature >80 °C
91	Ambient sensor open or short circuited
92	Internal sensor not calibrated
93	Communication error
94	fault with AL terminal connected
95	S5 digital sensor not detected
96	S6 digital sensor not detected
97	S7 digital sensor not detected
98	S8 digital sensor not detected
99	Digital outdoor sensor not detected



#### NOTE

- *Indicator 1 blinks if a fault code between 0 and 90 is displayed.*
- *Indicator 1 also blinks if fault code 93 is displayed.*

## 1.7.5 Restarting the air conditioning unit in the case of breakdown

Some of the failure indicators on the screen are false. They are apparent breakdowns caused by something other than operation of the unit; for example, air intake is blocked by an excess of accumulated snow or the presence of refuse (plastic bags, papers, branches, etc.).

In this case, the unit can be restarted by pressing the **MODE** key on the thermostat repeatedly until the display indicates **OFF**.

Then, restart the unit by pressing the **MODE** key and select the required operating mode.

The unit will start up normally if the cause of the fault is no longer present. If the cause persists, it is possible to start the unit a maximum of three times within a 24-hour period.

If the thermostat display keeps showing the pilot light -1- and any fault code or if the air conditioner does not start, contact a Johnson Controls Inc. Authorised Technical Assistance Service.

## 1.8 Regular maintenance activities for which the user is responsible

### 1.8.1 Maintenance Schedule

The air conditioning unit is designed to require as little maintenance as possible. Nevertheless, to ensure smooth operations with a minimal use of electricity, a long working life and compliance with the regulations of each country, regular maintenance inspections must be made.

Johnson Controls Inc. shall not be considered responsible for any damage caused by improper maintenance of the unit, which includes anything inconsistent with that described in this document or others specifically provided with the unit.

To make them easier, maintenance tasks have been grouped by time intervals in a series of tables. [Maintenance responsibilities of the user](#) , see on page 11 .

### 1.8.2 Maintenance responsibilities of the user

Like any other machine, the air conditioning unit requires regular maintenance, as the wear to which some of its parts are subjected can effect its mechanical reliability and the safety of those responsible for its maintenance.

In compliance with current regulations, the unit must be regularly inspected and the results recorded on the forms provided by the Labour and Health Authorities of the country where the air conditioning unit is installed.

As the air conditioner is installed on a roof, it is not possible that the user access it to carry out maintenance and upkeep.

There is no intent for the user to perform any maintenance tasks on the air conditioning unit.



**DANGER**

*It is strictly prohibited for the user to carry out any maintenance or upkeep tasks on the air conditioning unit.*

*Only trained Johnson Controls Inc. personnel with the necessary means and tools may carry out maintenance and upkeep work on the unit.*

*Trained personnel must be aware of the health and safety regulations and procedures applicable to air conditioning units. They should also be aware of general procedures and those applying specifically to this unit.*

*Contact a Johnson Controls Inc. Authorised Technical Assistance Service for scheduled maintenance on this unit.*

To discover the maintenance operations a Johnson Controls Inc. Authorised Technical Assistance Service should regularly perform, see [Maintenance Schedule](#) , see on page 11 .

## PRODUCT DISPOSAL

According to Directive 2002/96/EC of the European Parliament and of the Council of 27 January 2003, the presence of the symbol on the product or in the documents included with the product indicates that this product is classified, according to current law, as an electrical and electronic device and, therefore, this product cannot be dealt with at the end of its working life as domestic or urban waste.

The product must be taken to collection points for the recycling of waste electrical and electronic equipment.

The appropriate management, reuse, assessment and recycling of these products protect human health and the environment.

