

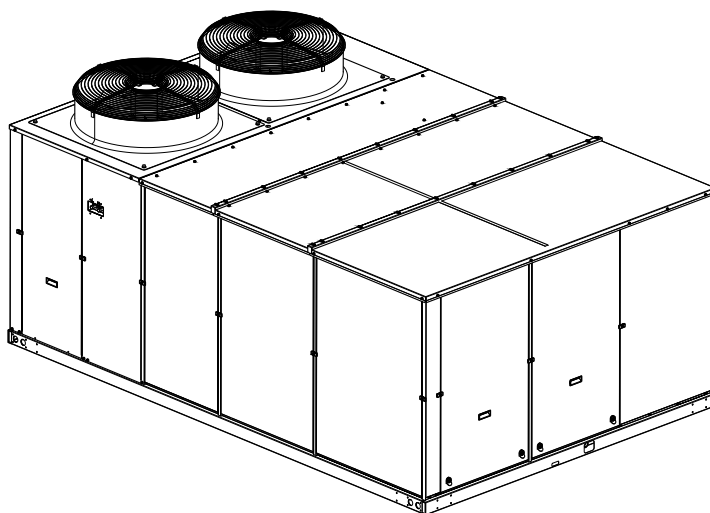

BY JOHNSON CONTROLS

ACTIVA SERIES ROOF TOP Air Conditioners 045/090



Installation manual

Ref.: N-40357_EN 0915



Index

1	Installation manual.....	1
1.1	Safety instructions.....	2
1.2	Icons used in this document.....	2
1.3	Instructions for storage, transport and handling of the unit.....	3
1.3.1	Disposal of packaging.....	3
1.3.2	Hoisting points.....	3
1.4	Technical data.....	5
1.4.1	Technical and physical data for ARC (only cooling) and ARG (only cooling + gas heating)....	5
1.4.2	ARH technical and physical data (heat pump) and ARD (heat pump + gas heating).....	7
1.4.3	Weight options and accessories.....	8
1.5	ARC units with auxiliary heating element.....	8
1.6	ARH units with auxiliary heating element.....	9
1.7	Limits of use.....	9
1.8	Capacities and application data for gas ARG/ARD.....	10
1.9	Hot water coil, optional in ARC/ARH.....	10
1.10	Measurements, clearances and accesses.....	12
1.10.1	Connections for supply and return side ducts.....	12
1.10.2	General dimensions and accesses (models 045/060).....	14
1.10.3	General dimensions and accesses (models 075/090).....	16
1.11	ARC/ARG Performance.....	17
1.11.1	ARC/ARG 045 Cooling capacities.....	17
1.11.2	ARC/ARG 060 Cooling capacities.....	18
1.11.3	ARC/ARG 075 Cooling capacities.....	18
1.11.4	ARC/ARG 090 Cooling capacities.....	19
1.12	ARH/ARD output.....	19
1.12.1	ARH/ARD 045 Cooling capacities.....	19
1.12.2	ARH/ARD 060 Cooling capacities.....	20
1.12.3	ARH/ARD 075 Cooling capacities.....	20
1.12.4	ARH/ARD 090 Cooling capacities.....	21
1.12.5	ARH/ARD 045 Thermodynamic heat capacity.....	21
1.12.6	ARH/ARD 060 Thermodynamic heat capacity.....	22
1.12.7	ARH/ARD 075 Thermodynamic heat capacity.....	22
1.12.8	ARH/ARD 090 Thermodynamic heat capacity.....	23
1.13	Indoor fan.....	23
1.13.1	Features table.....	23
1.13.2	Considerations when consulting the output tables.....	23
1.13.3	Output table for indoor fan, model ARC-045, applications with side ducts, standard drive motor 3 kW.....	24
1.13.4	Output table for indoor fan, model ARC-045, applications with side ducts, optional HPD drive motor 4 kW.....	24
1.13.5	Output table for indoor fan, model ARC-060, applications with side ducts, standard drive motor 4 kW.....	25

1.13.6	Output table for indoor fan, model ARC-060, applications with side ducts, optional HPD drive motor 5.5 kW.....	25
1.13.7	Output table for indoor fan, model ARC-075, applications with side ducts, standard drive motor 5.5 kW.....	25
1.13.8	Output table for indoor fan, model ARC/ARH-075, applications with side ducts, optional HPD drive motor 7.5 kW.....	26
1.13.9	Output table for indoor fan, model ARC/ARH-090, applications with side ducts, standard drive motor 7.5 kW.....	26
1.13.10	Output table for indoor fan, model ARC/ARH-090, applications with side ducts, optional HPD drive motor 11 kW.....	26
1.14	Pressure drop of options/accessories, gas heating and vertical ducts.....	27
1.15	Instructions for installation and connection of the unit.....	27
1.15.1	Characteristics of the location.....	27
1.15.2	Characteristics of the facility where the unit will be installed.....	28
1.15.3	Specifications for the foundation or anchoring of the unit.....	28
1.15.4	Installation on shock absorbers.....	29
1.15.5	Characteristics of utility provider connections.....	29
1.15.6	Connection and preparation of the various connections.....	30
1.16	Instructions for starting up the unit.....	35
1.16.1	Electrical checks.....	35
1.16.2	Starting the gas heating, ARG/ARD.....	35
1.17	Unblocking the unit safely in case of breakdown.....	39
1.18	Regular maintenance tasks performed by specialised personnel.....	39
1.18.1	Planned Maintenance Schedule.....	40
1.18.2	Maintenance tasks performed by specialised personnel.....	40
1.18.3	Gas heating (ARG/ARD Models).....	43
1.19	Unit sound pressure data.....	45
2	Unit installation data.....	46
2.1	List of tests for unit start-up.....	47
2.2	Start-up data.....	48
3	Cooling diagrams.....	52
3.1	ARC/ARG 045/060 Cooling diagrams.....	53
3.2	ARC/ARG 075 Cooling diagrams.....	54
3.3	ARC/ARG 090 Cooling diagrams.....	55
3.4	ARH/ARD 045/060 Cooling diagrams.....	56
3.5	ARH/ARD 075 Cooling diagrams.....	57
3.6	ARH/ARD 090 Cooling diagrams.....	58
4	Wiring diagrams	59
4.1	Micro switch configuration.....	60
4.2	Fault table.....	61
4.3	Incidents.....	62
4.3.1	Test button.....	63
4.4	DPC-1 thermostat.....	63
4.5	Unit wiring diagrams.....	64

1

Installation manual

1.1 Safety instructions

This document contains the necessary information for the safe and efficient transportation, assembly and installation of the air conditioning unit. This guarantees the condition of the unit and its operating safety.

Only an authorised company may assemble the air conditioning unit.



ATTENTION

Only authorised companies with the appropriate technical resources and suitably trained personnel may install the air conditioning unit.



CAUTION

The specialists responsible for installing the air conditioning unit must make sure they have all of the information and knowledge required to correctly install, test and deliver the unit. Johnson Controls Inc. shall not be considered responsible for any damage caused by installation of the unit that is not consistent with that described in this document or others specifically provided with the unit.

During regular equipment installation, the fitter must pay special attention to certain situations in order to prevent injuries or damage to the unit.

Situations that could jeopardise the safety of the fitter or that of others nearby or that could put the unit itself at risk are clearly indicated in this manual.

A series of special symbols are used to clearly identify these situations.

Pay careful attention to these symbols and to the messages following them, as your safety and the safety of others depends on it.

1.2 Icons used in this document



DANGER

- *The text following this symbol contains information and instructions relating directly to your safety and physical wellbeing.*
- *Not taking these instructions into account could lead to serious, very serious or even fatal injuries to you and others in the proximities of the unit.*

Information can also be found on safe procedures during unit handling. This will help reduce the risk of accidents.



CAUTION

- *The text following this symbol contains information and instructions relating directly to your safety and physical wellbeing.*
- *Not taking these instructions into account could lead to minor injuries to you and others in the proximities of the unit.*
- *Not taking these instructions into account could lead to unit damage.*

Information can also be found on safe procedures during unit handling. This will help reduce the risk of accidents.



NOTE

- *The text following this symbol contains information or instructions that may be of use or that is worthy of a more thorough explanation.*
- *Instructions regarding inspections to be made on unit parts or systems may also be included.*

1.3 Instructions for storage, transport and handling of the unit

Delivery inspection

The unit should be carefully inspected for visible damage or abnormalities as soon as it is received.

Any abnormalities or damage to the unit should be communicated to both the transportation and insurance company in writing.

Storage instructions

The unit should be stored in a place suitable to the purpose (warehouse or similar), protected from the weather, water, humidity and dust.

Cover the unit with a canvas of a suitable size.

The unit should be appropriately protected from knocks and dust, ensuring the protective parts it was supplied with remain in place. Where these are not in place, establish the necessary protections and/or barriers to keep vehicles or fork-lift trucks away.

Transport and handling of the unit

The units should only be handled by personnel from the company responsible for their installation.

Transport of the unit should be in such a manner that no damage is caused by faulty or inadequate mooring to the bed or body of the vehicle.

Where necessary, protect all of the edges of the unit against knocks and scratches and moor it to the bed or body of the vehicle using suitable textile belts or slings to keep it perfectly still.

Loading and unloading the unit from a truck or trailer should be on flat, solid ground using an appropriate crane with sufficient capacity.



CAUTION

It is strictly prohibited to use fork lifts to load, unload, or handle the unit.

1.3.1 Disposal of packaging

The packaging is recyclable. Dispose of it in the appropriate place or take it to an appropriate collection centre. Respect the regulations in force for this type of waste in the country where the unit is being installed.

Packaging remains must be correctly disposed of. Improper disposal of packaging generates environmental problems that affect human life.

1.3.2 Hoisting points

The points designed for hoisting the unit are located on the beams on its base -**arrows**-.

Before hoisting the unit, check that the cables or slings are firmly hooked to these points and make sure the crane and the cables or slings are capable of lifting the weight.

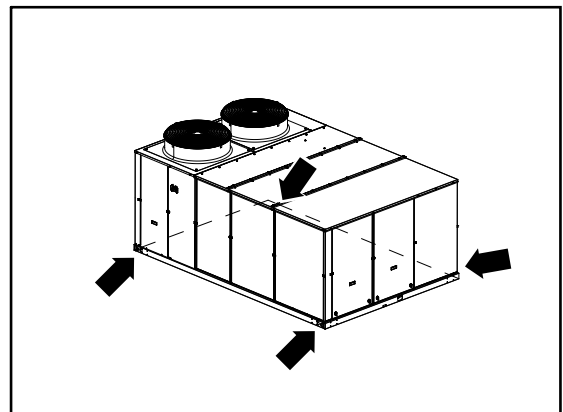

Place spacers -1- at the top of the unit to prevent the cables or slings from touching it.

Attach guide ropes so that the unit does not rotate freely.

The cables or slings should be long enough to form an angle of over 45° to the horizontal plane. Hoist the unit keeping it in a horizontal position.



DANGER

There should not be onlookers within a radius of 10 m of the unit when it is being hoisted.

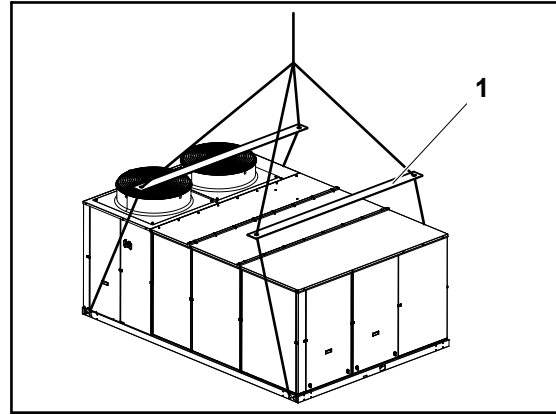

Centre of gravity of the unit

Models	045	060	075	090
A	1180	1180	1135	1080
B	1390	1425	1480	1540
C	3180	3180	3495	3495
D	2337	2337	2337	2337

All measurements in mm.

1. Centre of gravity
2. End of the outdoor coil

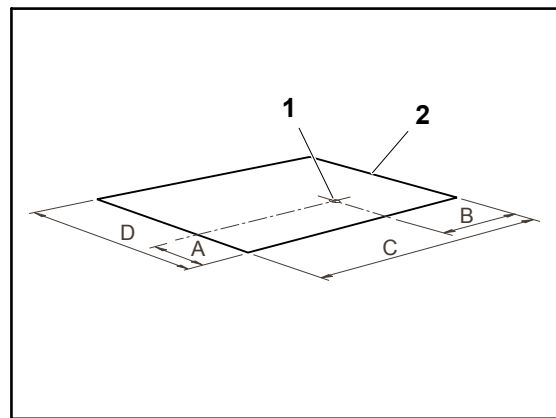

1.4 Technical data

1.4.1 Technical and physical data for ARC (only cooling) and ARG (only cooling + gas heating)

Models		ARC/ARG	045	060	075	090
Cooling capacity (1)	Net cooling capacity	kW	45.1	61	71.5	84
	Rated absorbed power in cool mode	kW	16	23	30	36
Heating (ARC)	Optional electric heater, heating capacity (400 V) (2)	kW	12-25-37-50			
Gas Heating (ARG)	Heat capacity at 100% power (standard)	(LHV) Total kW	85			
		Net (2) kW	76			
	Heat capacity at 100% power, high capacity (optional)	Total kW	100			
		Net (2) kW	90			
	100% gas consumption (2ND-H natural gas, G20 at 20 mbar and 15 °C) (standard)	m ³ /h	8.6			
	100% gas consumption (2ND-H natural gas, G20 at 20 mbar and 15°C) high capacity (optional)	m ³ /h	9.8			
Stages	No.	2				
Compressors	Rated/start-up current	A	2x12/95	2x15/118	2x20/140	2x25/198
	Type and quantity		SCROLL, 1 (TANDEM 50% + 50%)			
	Degree of protection		IP21			
Coolant (R-410A)		kg	10.5	18.2	20.5	29
Power supply		V/ph/Hz	400/3+N/50			
Indoor fan (3)	Rated air flow	m ³ /h	8500	11500	13500	16000
	Maximum static pressure with rated flow (standard)	Pa	182	270	240	368
	Maximum static pressure with rated flow (optional HPD drive)	Pa	368	430	>500	>500
	Maximum flow rate	m ³ /h	10000	13500	16000	18000
	Minimum flow rate	m ³ /h	7000	9500	11500	13000
	IP55 motor (standard)	kW	3	4	5.5	7.5
	Rated current	A	5.5	5.7	7.6	11.7
	IP55 Motor (HPD optional)	kW	4	5.5	7.5	11
	Rated current	A	5.7	7.6	11.7	14/17.4
Indoor coil (evaporator)	Number of elements	No.	2	3	3	4
	Distance between fins	mm	1.81	1.81	1.81	1.81
	Front surface	m ²	1.44	1.58	1.95	1.06 (x 2)
Air filters (G4)	Quantity per unit	No.	6		6	
	Dimensions	mm	470x550x48		565x594x48	
Outdoor fan	Diameter/number	mm	800/1	800/2	800/2	800/2
	Total rated flow	m ³ /h	15000	23000	27000	27000
	Motor (IP54)	kW	1.9	1.9	1.9	1.9
	Rated current	A	3.5	2x3.5	2x3.5	2x3.5
Outdoor coil (condenser)	Number of elements	No.	2	3	2	3
	Distance between fins	mm	1.81	1.81	1.81	1.81
	Front area	m ²	2.27	2.49	2.31 (x2)	2.31 (x2)
Net dimensions (4)	Height	mm	1316		1367	
	Length	mm	3180		3495	
	Width	mm	2337		2337	
Net weight (basic unit without accessories) (4)	ARC	kg	900	945	1118	1142
	ARG	kg	1010	1055	1228	1252

1.4 Technical data

Models		ARC/ARG	045	060	075	090
Electrical features of the unit	Total rated power	kW	16	23	30	36
	Total rated current	A	32	42	54	70
	Total maximum power	kW	23	31	38	45
	Total maximum current	A	42	56	70	83
	Circuit breaker (K curve) (5)	A	50	63	80	100
	Minimum cable section (6)	mm ²	10	16	25	35

(1) Data in accordance with Eurovent conditions, summer: indoor 27 °C DBT / 19 °C WBT - outdoor DBT 35 °C. (DBT Dry-bulb temperature; WBT Wet-bulb temperature).

(2) Add the inside motor consumption to find the total calorific capacity.

(3) See [Indoor fan](#), see on page 23.

(4) Consider the additional weight of options and accessories. To do so, see [Weight options and accessories](#), see on page 8.

LHV: Lower heating value.

(5) and (6) Circuit breaker with K curve, according to DIN, VDE 0660-104. Cable section for the power supply line based on copper conductors, 105 °C. The indicated circuit breaker and the section of power supply cables are guidelines. They should be adjusted based on the requirements of each installation, distance between units, fall in planned voltage and on the application of the current regulations with respect to the country where the unit is being installed.

1.4.2 ARH technical and physical data (heat pump) and ARD (heat pump + gas heating)

Models		ARH/ARD	045	060	075	090
Cooling capacity (1)	Net cooling capacity	kW	47.6	61.9	71.4	83.4
	Rated absorbed power in cool mode	kW	17	20	28	36
Heat capacity	Heat capacity (2)	kW	45.2	58	71.7	86.5
	Rated power absorbed in heat mode	kW	16	19	27	33
	Optional electric heater, heating capacity (400 V) (ARH) (2)	kW	12-25-37-50			
Gas Heating (ARG)	Heat capacity at 100% power (standard)	(LHV) Total kW	85			
		Net (2) kW	76			
	Heat capacity at 100% power, high capacity (optional)	Total kW	100			
		Net (2) kW	90			
	100% gas consumption (2ND-H natural gas, G20 at 20 mbar and 15 °C) (standard)	m ³ /h	8.6			
	100% gas consumption (2ND-H natural gas, G20 at 20 mbar and 15°C) high capacity (optional)	m ³ /h	9.8			
Stages	No.	2				
Compressors	Rated/start-up current	A	2x12/95	2x15/118	2x20/140	2x25/198
	Type and quantity		SCROLL, 1 (TANDEM 50 % + 50 %)			
	Degree of protection		IP21			
Coolant (R-410A)		kg	14.5	19	20.5	29
Power supply		V/ph/Hz	400/3+N/50			
Indoor fan (3)	Rated air flow	m ³ /h	8500	11500	13500	16000
	Maximum static pressure with rated flow (standard drive)	Pa	168	242	240	368
	Maximum static pressure with rated flow (optional HPD drive)	Pa	335	402	>500	>500
	Maximum flow rate	m ³ /h	10000	13500	16000	18000
	Minimum flow rate	m ³ /h	7000	9500	11500	13000
	IP55 motor (standard)	kW	3	4	5.5	7.5
	Rated current	A	5.5	5.7	7.6	11.7
	IP55 Motor (HPD optional)	kW	4	5.5	7.5	11
Indoor coil (evaporator)	Number of elements	No.	3	4	3	4
	Distance between fins	mm	2.11	2.11	1.81	1.81
	Front surface	m ²	1.44	1.58	1.95	1.06 (x 2)
Air filters (G4)	Quantity per unit	No.	6		6	
	Dimensions	mm	470x550x48		565x594x48	
Outdoor fan	Diameter/number	mm	800/1	800/2	800/2	800/2
	Total rated flow	m ³ /h	15000	23000	27000	27000
	Motor (IP54)	kW	1.9	1.9	1.9	1.9
	Rated current	A	3.5	2x3.5	2x3.5	2x3.5
Outdoor coil (condenser)	Number of elements	No.	3	4	2	3
	Distance between fins	mm	2.11	2.54	1.81	1.81
	Front area	m ²	2.27	2.49	2.31 (x2)	2.31 (x2)
Net dimensions (4)	Height	mm	1316		1367	
	Length	mm	3180		3495	
	Width	mm	2337		2337	
Net weight (basic unit without accessories) (4)	ARH	kg	930	985	1145	1220
	ARD	kg	1040	1095	1255	1330

1.5 ARC units with auxiliary heating element

Models		ARH/ARD	045	060	075	090
Electrical features of the unit	Total rated power	kW	17	22	28	36
	Total rated current	A	32	42	54	70
	Total maximum power	kW	23	31	38	45
	Total maximum current	A	42	56	70	83
	Circuit breaker (K curve) (5)	A	50	63	80	100
	Minimum cable section (6)	mm ²	10	16	25	35

(1) Data in accordance with Eurovent conditions, summer: indoor 27 °C DBT / 19 °C WBT - outdoor DBT 35 °C. Winter: Indoor DBT 20 °C, outdoor DBT 7 °C/WBT 6 °C (DBT Dry-bulb temperature; WBT Wet-bulb temperature).

(2) Add the inside motor consumption to find the total calorific capacity.

(3) See *Indoor fan*, see on page 23

(4) Consider the additional weight of options and accessories. To do so, see *Weight options and accessories*, see on page 8.

LHV: Lower heating value.

(5) and (6) Circuit breaker with K curve, according to DIN, VDE 0660-104. Cable section for the power supply line based on copper conductors, 105 °C. The indicated circuit breaker and the section of power supply cables are guidelines. They should be adjusted based on the requirements of each installation, distance between units, fall in planned voltage and on the application of the current regulations with respect to the country where the unit is being installed.

1.4.3 Weight options and accessories

Models		045	060	075	090	
Economiser	kg	65	65	73	73	
Exhaust fan (axial)	kg	54	54	63	63	
Return fan (centrifuge)	kg					
Roof-curb mounting base (fixed/adjustable)	kg	81/157	81/157	85/165	85/165	
ERP adaptor for Roof Curb	kg	177	177	190	190	
Heating element	kg	20	20	20	20	
Hot water coil	kg	60	60	60	60	
Fixed outdoor air intake	kg	9	9	9	9	
Barometric damper	kg	20	20	20	20	
Copper fin coil	ARC/ARG	indoor	19	31	44	64
		outdoor	30	49	70	104
	ARH/ARD	indoor	29	48	44	64
		outdoor	44	64	70	104

1.5 ARC units with auxiliary heating element

ARC Model	Power supply V/Ph/Hz	Heating element			Maximum total current of the unit (A)	Maximum circuit breaker (K Curve) (1)	Minimum cable cross-section (mm ²) (2)
		Power (kW)	Stages (No.)	Current (A)			
045	400/3/50	12	1	18	32	50	10
		25	2	36	38	50	10
		37	2	54	60	80	25
		50	2	72	78	100	35
060	400/3/50	12	1	18	42	50	10
		25	2	36	42	50	10
		37	2	54	60	80	25
		50	2	72	78	100	35
075	400/3/50	12	1	18	54	63	16
		25	2	36	54	63	16
		37	2	54	62	80	25
		50	2	72	80	100	35
090	400/3/50	12	1	18	70	80	25
		25	2	36	70	80	25
		37	2	54	70	80	25
		50	2	72	84	100	35

- (1) K Curve (DIN, VDE 0660-104).
(2) Based on copper conductors 105 °C.

1.6 ARH units with auxiliary heating element

ARC Model	Power supply V/Ph/Hz	Heating element			Maximum total current of the unit (A)	Maximum circuit breaker (K Curve) (1)	Minimum cable cross-section (mm ²) (2)
		Power (kW)	Stages (No.)	Current (A)			
045	400/3/50	12	1	18	50	63	16
		25	2	36	68	80	25
		37	2	54	86	100	35
		50	2	72	104	125	50
060	400/3/50	12	1	18	60	80	25
		25	2	36	78	100	35
		37	2	54	96	125	50
		50	2	72	114	125	50
075	400/3/50	12	1	18	72	80	25
		25	2	36	90	100	35
		37	2	54	108	125	50
		50	2	72	126	160	70
090	400/3/50	12	1	18	88	100	35
		25	2	36	106	125	50
		37	2	54	124	160	70
		50	2	72	142	160	70

- (1) K Curve (DIN, VDE 0660-104).
(2) Based on copper conductors 105 °C.

1.7 Limits of use

Model				045	060	075	090	
Voltage limits				Min./Max V				
				360/440				
ARC/ARG	Temperature of air inlet in indoor coil		WB °C Min./Max.	15/23	15/23	15/23	15/23	
			DB °C Min/Max	20/32	20/32	20/32	20/32	
	Outdoor temperature (without condensation control)		TS °C Min.	7	7	7	7	
	Maximum outdoor temperature (1)	At full load	TS °C	46	46	46	46	
At partial load		TS °C	52	52	52	52		
ARH/ARD	Summer cycle	Temperature of air inlet in indoor coil		WB °C Min./Max.	15/23	15/23	15/23	14/23
				DB °C Min/Max	20/32	20/32	20/32	20/32
		Outdoor temperature (without condensation control)		TS °C Min.	7	7	7	7
		Maximum outdoor temperature (1)	At full load	TS °C	46	46	46	46
	At partial load		TS °C	52	52	52	52	
	Winter cycle	Temperature of air inlet in indoor coil		DB °C Min/Max	10/25	10/25	10/25	10/25
Outdoor temperature		DB °C Min/Max	-10/20	-10/20	-10/20	-10/20		
ARG/ARD (2)	Gas heating	Indoor temperature		TS °C Max	30	30	30	
		Outdoor temperature		DB °C Min/Max	-15/25	-15/25	-15/25	-15/25

- Direct sunlight on the unit should be prevented when temperatures are higher than 43°C. If placed under some kind of protective cover, the cover should not interfere with the flow of outdoor ventilation.
 - The gas heating units (ARG/ARD) are only appropriate for use with gas. In LPG (Liquefied Petroleum Gas, propane) installations, it must be ensured that in no case should gasoline in liquid form reach the gas group.
- DB: Dry-bulb Thermometer; TH: Wet-bulb thermometer.

1.8 Capacities and application data for gas ARG/ARD

1.8 Capacities and application data for gas ARG/ARD

Model	Heat capacity				Gas consumption m ³ /h			Temperature rise in °C at full power (4)	
	Total (LHV) (1) kW		Net kW		Natural gas (2)		L.P.G. propane (3)		
	Standard	High power	Standard	High power	Standard	High power	Optional (only standard)	Min.	Max.
045	85	100	76	90	8,6	9,8	3,6	17	33
060	85	100	76	90	8,6	9,8	3,6	17	33
075	85	100	76	90	8,6	9,8	3,6	17	33
090	85	100	76	90	8,6	9,8	3,6	17	33

(1) LHV: Lower heating value.

(2) Natural gas 2ND-H, G20, at 20 mbar and 15 °C

(3) Propane gas, G31, at 37 mbar and 15 °C.

(4) The air flow should be regulated so as to increase temperature within the specified limits. Units with optional high power burners should have a minimum air flow of 10000 m³/h.

Note: The gas units are shipped ready to operate with natural gas. A conversion kit can be used to convert them to propane gas (L.P.G.).

1.9 Hot water coil, optional in ARC/ARH

ARC/ARH		Data with water, without glycol								
		045			060		075		090	
Water temperature	°C	90 ÷ 70								
Air flow rate	m ³	7000	8500	10000	11500	13500	15000	16000	17000	18000
Heat capacity	kW	71,1	79,5	87,0	93,7	101,7	107,3	111	114,2	117,4
Water flow rate	m ³ /h	3	3,3	3,7	4	4,3	4,5	4,7	4,8	5
Pressure drop	kPa	9,5	11	14	16	19	21	22	23	25
Air temperature rise	K	30	27	25	24	22	21	20	19	18
Water temperature	°C	80 ÷ 60								
Air flow rate	m ³	7000	8500	10000	11500	13500	15000	16000	17000	18000
Heat capacity	kW	58,6	65,4	71,5	77	83,5	88,1	90,8	93,7	96,3
Water flow rate	m ³ /h	2,5	2,8	3	3,3	3,5	3,7	3,9	4	4,1
Pressure drop	kPa	7,5	9	9,5	11	13	14	16	16	18
Air temperature rise	K	24	22	21	20	18	17	17	16	15
Water temperature	°C	70 ÷ 50								
Air flow rate	m ³	7000	8500	10000	11500	13500	15000	16000	17000	18000
Heat capacity	kW	46,0	51,2	55,8	61,1	65,1	68,7	71	73	75
Water flow rate	m ³ /h	1,9	2,2	2,4	2,6	2,8	2,9	3	3,1	3,2
Pressure drop	kPa	4,5	6	6,5	7,5	9	9,5	10,5	11	11
Air temperature rise	K	19	18	16	15	14	13	13	12	12

- Pressure drop of coil + 3-way valve.

- Coil air inlet: 18 °C.

- Total volume of water in circuit 10 l.

- See air pressure drop, *Pressure drop of options/accessories, gas heating and vertical ducts.*, see on page 27.

ARC/ARH		Data with a mix of water and 35% glycol									
							090				
					060		075				
		045									
Water temperature	°C	90 + 70									
Air flow rate	m ³	7000	8500	10000	11500	13500	15000	16000	17000	18000	
Heat capacity	kW	68,5	76,3	83,6	89,8	97,5	102,8	106,3	109,4	112,4	
Water flow rate	m ³ /h	3,2	3,6	4	4,2	4,6	4,8	5	5,1	5,3	
Pressure drop	kPa	12	15	17	20	23	25	27	28	30	
Air temperature rise	K	28	26	24	22	21	20	19	18	17	
Water temperature	°C	80 + 60									
Air flow rate	m ³	7000	8500	10000	11500	13500	15000	16000	17000	18000	
Heat capacity	kW	55,6	62	67,7	72,8	79	83,3	85,9	88,5	91	
Water flow rate	m ³ /h	2,6	2,9	3,2	3,5	3,7	4	4,1	4,2	4,3	
Pressure drop	kPa	9	10	12	14	16	18	19	20	21	
Air temperature rise	K	23	21	20	18	17	16	16	15	14	
Water temperature	°C	70 + 50									
Air flow rate	m ³	7000	8500	10000	11500	13500	15000	16000	1700	18000	
Heat capacity	kW	41,4	46	50,7	54,8	59,6	63,1	65,3	67,3	69,2	
Water flow rate	m ³ /h	2	2,2	2,4	2,6	2,8	3	3,1	3,2	3,3	
Pressure drop	kPa	6	6,5	7	8,5	10	11	12	13	14	
Air temperature rise	K	17	16	15	14	13	12	12	11	11	

- Pressure drop of coil + 3-way valve.
- Coil air inlet: 18 °C.
- Total volume of water in circuit 10 l.
- See air pressure drop, *Pressure drop of options/accessories, gas heating and vertical ducts.*, see on page 27.

1.10 Measurements, clearances and accesses

1.10.1 Connections for supply and return side ducts

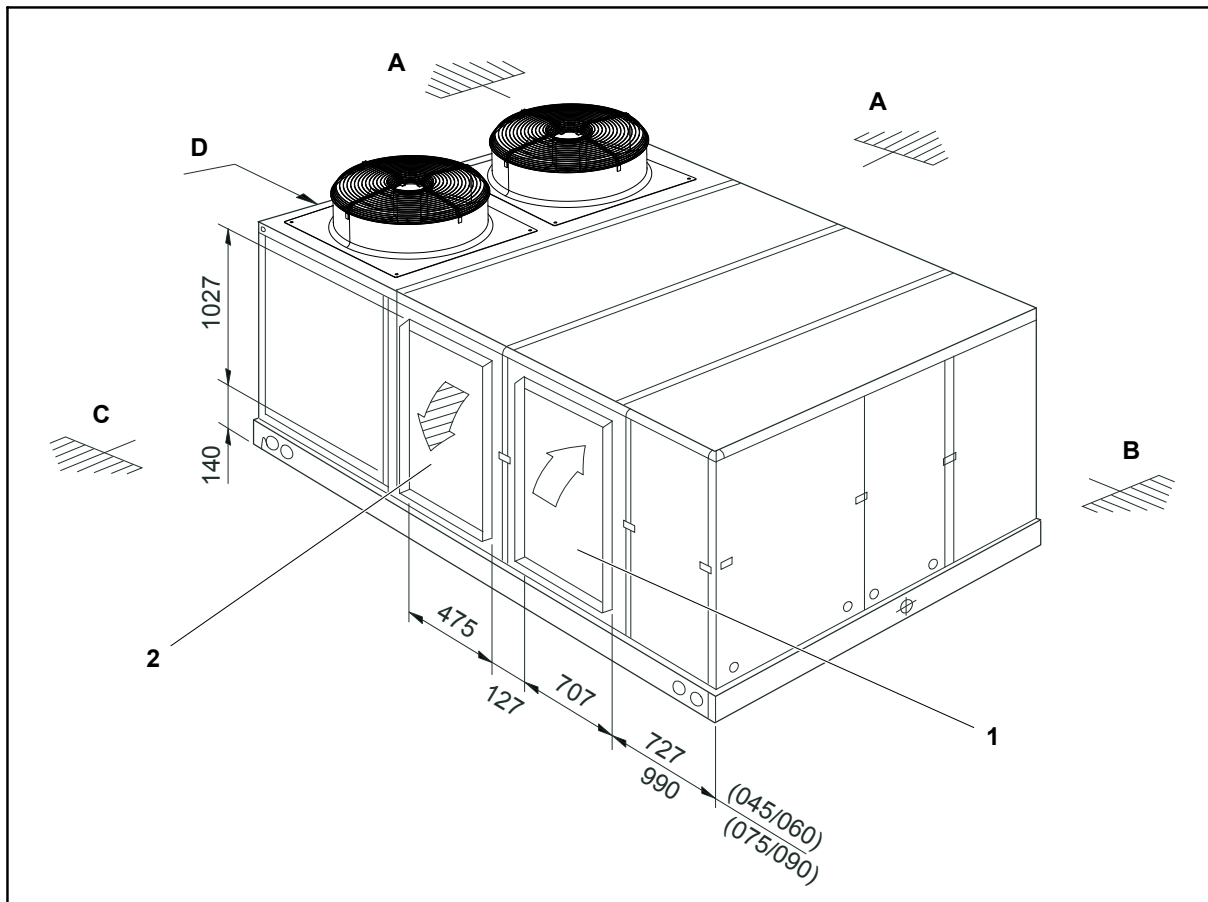

Minimum clearance

- A. Minimum clearance: 900 mm
- B. Minimum clearance: 600 mm (without economiser); 1200 mm (with economiser)
- C. Minimum clearance: 600 mm (without economiser); 1245 mm (with economiser)
- D. Outdoor coil
- 1. Return air
- 2. Supply air

Units are shipped with the lower duct openings covered.

For applications with downward airflow ducts:

1. In order to access the covers of the lower supply and return air ducts, remove the side panels of the supply and return air compartments.
2. Remove and discard the lower duct covers.
3. Replace the side panels of the supply and return air compartments. Make sure that the seal is completely air-tight and check that the bolts that fasten the panel have their corresponding o-rings.

For applications with sideways airflow ducts:

Flanges for connecting the side ducts are included in an accessory kit.

1. Replace the side panels of the supply and return air compartments with the set of accessory panels. Make sure that the seal is air-tight.
2. Connect the duct system to the panel flanges.

Minimum clearance above the unit

The unit is designed to be installed outdoors.

In ground level installations, the building eaves should be at a vertical distance of at least 1830 mm from the top of the unit and should not overhang the unit more than 915 mm.

There are no restrictions regarding the overhang if the eaves are 3000 mm or more above the unit.

1.10.2 General dimensions and accesses (models 045/060)

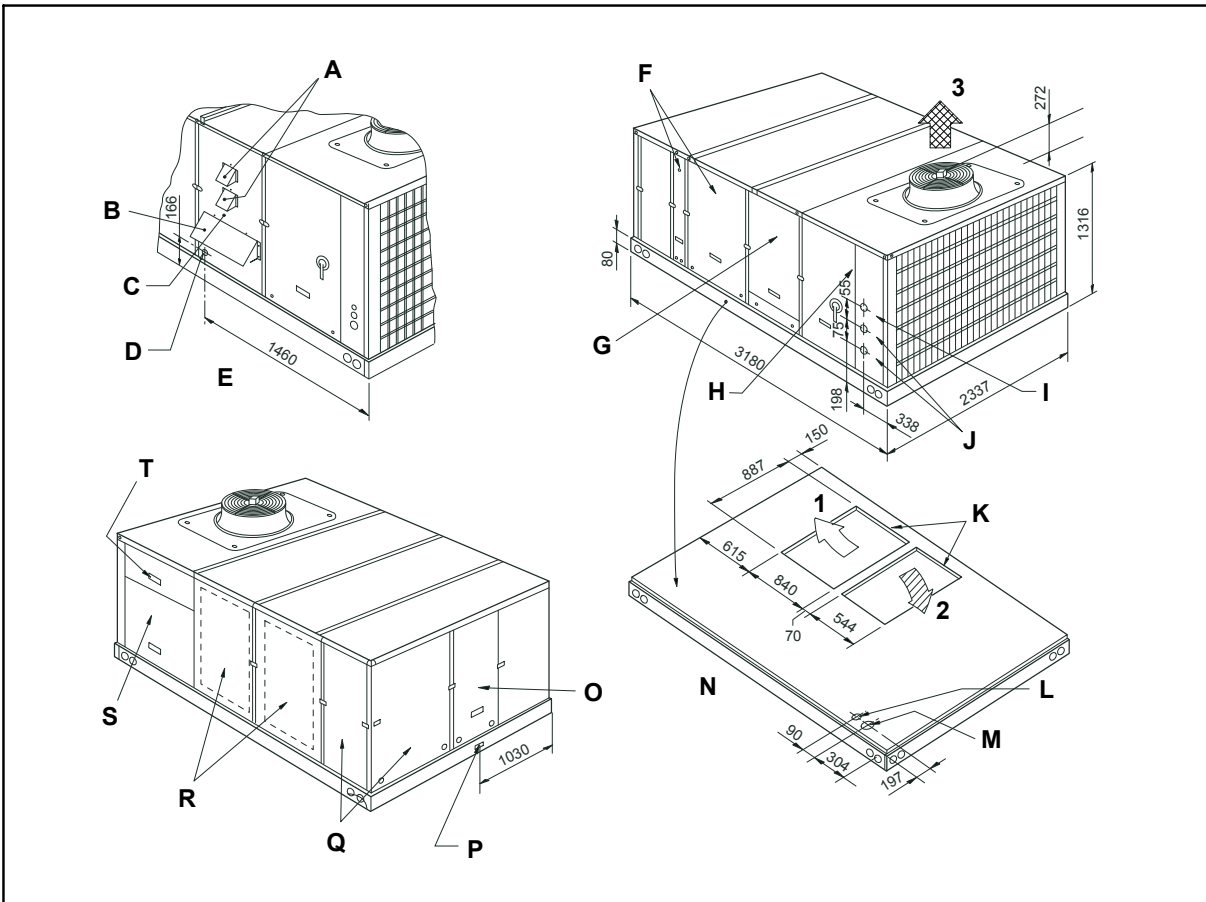

- A. Combustion gas outlet hood
- B. Combustion air input hood
- C. Access to gas heating system
- D. Gas supply intake (Ø 58 mm), with rubber grommet
- E. ARG/ARD unit details
- F. Access to motor, fan and pulleys
- G. Access to heating options
- H. Access to control system
- I. Control cable intake (Ø 23 mm) (side)
- J. Power cable intake (Ø 38 + 29 mm) (side)
- K. Opening for connection of lower supply and return air ducts.
- L. Control cable intake (PG 21 mm) (lower)
- M. Power cable intake (PG 48 mm) (lower)
- N. Close-up of the base, shown separately to be more easily seen
- O. Access to filters and indoor coil
- P. Condensate drain connection (1" BSP Female)
- Q. Access to the outdoor air compartment
- R. Supply and return air compartment side panels See [Connections for supply and return side ducts](#), ver *pág. 12*
- S. Compressor access
- T. Pressure reading connection
 - 1. Return air
 - 2. Supply air
 - 3. Condensation air (Models 045: 1 fan / Models 060: 2 fans)

1.10.3 General dimensions and accesses (models 075/090)

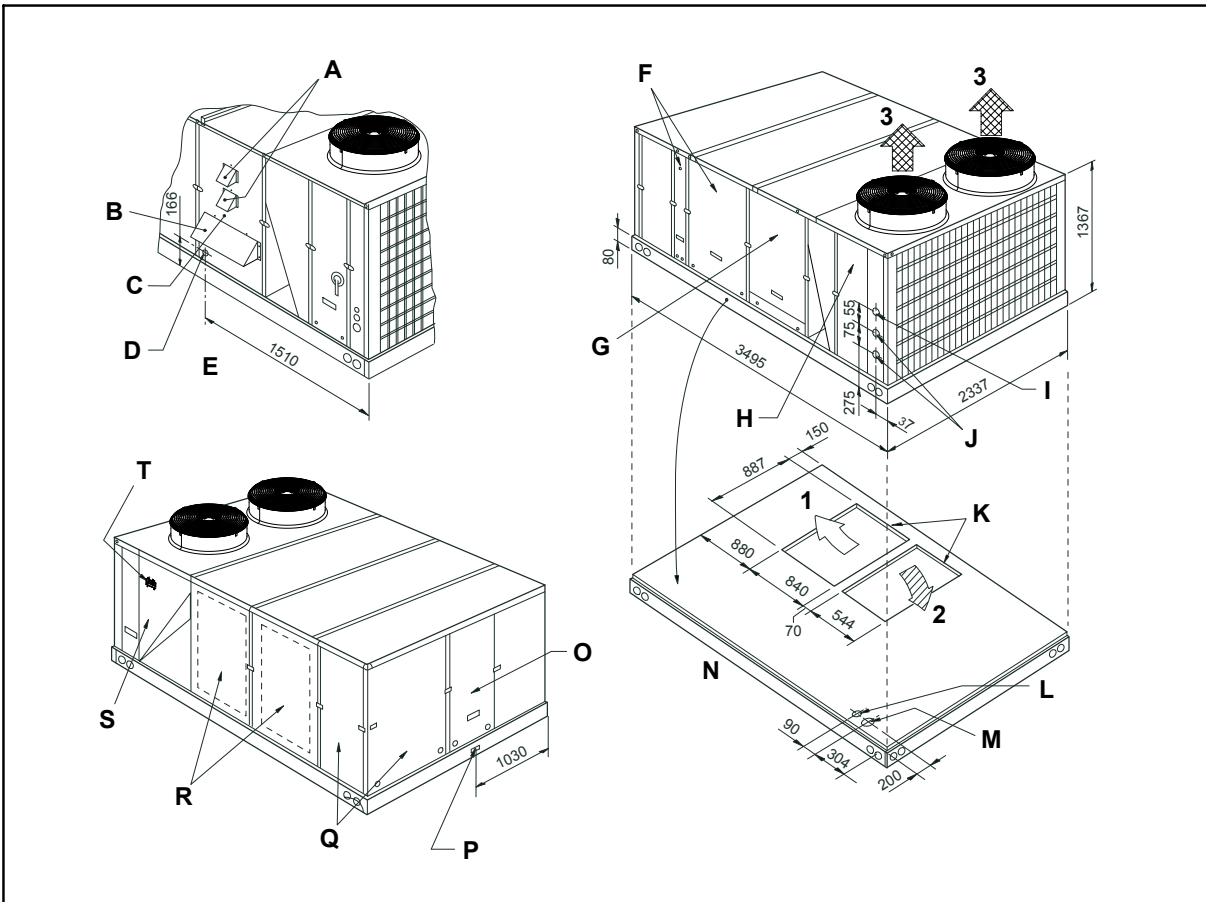

- A. Combustion gas outlet hood
- B. Combustion air input hood
- C. Access to gas heating system
- D. Gas supply intake (Ø 58 mm), with rubber grommet
- E. RAG/RAD unit details
- F. Access to motor, fan and pulleys
- G. Access to heating options
- H. Access to control system
- I. Control cable intake (Ø 23 mm) (side)
- J. Power cable intake (Ø 38 + 29 mm) (side)
- K. Opening for connection of lower supply and return air ducts.
- L. Control cable intake (PG 21 mm) (lower)
- M. Power cable intake (PG 48 mm) (lower)
- N. Close-up of the base, shown separately to be more easily seen
- O. Access to filters and indoor coil
- P. Condensate drain connection (1" BSP Female)
- Q. Access to the outdoor air compartment
- R. Supply and return air compartment side panels See *Connections for supply and return side ducts, ver pág. 12*
- S. Compressor access
- T. Pressure reading connection
 - 1. Return air
 - 2. Supply air
 - 3. Condensate air

1.11 ARC/ARG Performance

1.11.1 ARC/ARG 045 Cooling capacities

Return air		Outdoor coil air temperature (TS)																	
Flow rate m³/h	TH °C	27 °C				35 °C				46 °C									
		PT kW	PC kW	Sensible power kW				PT kW	PC kW	Sensible power kW				PT kW	PC kW	Sensible power kW			
				TS inlet temp. in indoor coil						TS inlet temp. in indoor coil						TS inlet temp. in indoor coil			
		30	27	24	22	30	27	24	22	30	27	24	22	30	27	24	22		
(Mini- mum) 7000	23	50.9	10.9	29.4	23.5	17.6	-	48.3	12	28.5	22.6	16.7	-	43.5	13.2	26.9	21	15.1	-
	19	46.1	10.6	38.3	32.5	26.6	22.7	43.5	11.5	37.3	31.4	25.5	21.6	39.1	12.4	35.6	29.8	23.9	19.9
	17	43.5	10.4	42.7	36.8	30.9	35.6	40	11.4	40	35.1	29.2	30.4	35.7	12.3	35.7	33.4	27.5	23.5
	15	39.1	10.2	39.1	39.1	34.1	30.1	37.4	11.2	37.4	37.4	33.1	29.2	33.5	12.2	33.5	33.5	31.5	27.5
(Nominal) 8500	23	52.8	11.1	32	25.1	18.2	-	50.1	12.2	31.1	24.2	17.3	-	45.1	13.5	29.5	22.6	15.7	-
	19	47.8	10.8	42.4	35.5	28.6	24	45.1*	11.7*	41.3	34.4*	27.5	22.9	40.6	12.6	39.7	32.7	25.8	21.2
	17	45.1	10.5	45.1	40.5	33.6	41.3	41.5	11.6	41.5	38.9	31.9	34	37	12.5	37	37	30.2	25.6
	15	40.6	10.4	40.6	40.6	37.5	32.9	38.8	11.3	38.8	38.8	36.5	31.9	34.7	12.4	34.7	34.7	34.7	30.2
(Maxi- mum) 10000	23	54.1	11.3	34.5	26.6	18.7	-	51.4	12.4	33.5	25.7	17.8	-	46.3	13.7	32	24.1	16.2	-
	19	49.1	10.9	46.2	38.3	30.4	25.2	46.3	11.9	45.1	37.2	29.3	24.1	41.7	12.9	41.7	35.6	27.7	22.4
	17	46.3	10.7	46.3	44	36.2	46.3	42.6	11.8	42.6	42.3	34.4	37.4	38	12.7	38	38	38	27.4
	15	41.7	10.6	41.7	41.6	40.7	35.4	39.8	11.5	39.8	39.8	39.7	34.5	35.7	12.6	35.7	35.7	35.7	32.8

* Data in accordance with Eurovent Rooftop program certification conditions

1.11 ARC/ARG Performance

PT: Total Power; PC: Power absorbed by the compressor
 WB: Wet-bulb temperature; TS: Dry bulb temperature.

1.11.2 ARC/ARG 060 Cooling capacities

Return air		Outdoor coil air temperature (TS)																	
Flow rate m³/h	TH °C	27 °C						35 °C						46 °C					
		PT kW	PC kW	Sensible power kW				PT kW	PC kW	Sensible power kW				PT kW	PC kW	Sensible power kW			
				TS inlet temp. in indoor coil						TS inlet temp. in indoor coil						TS inlet temp. in indoor coil			
		30	27	24	22	30	27	24	22	30	27	24	22						
(Minimum) 9500	23	68.8	14.6	41.3	32.5	23.8	-	65.3	16	40	31.3	22.5	-	58.8	17.7	38	29.2	20.5	-
	19	62.3	14.2	54.5	45.7	36.9	31.1	58.8	15.4	53	44.3	35.5	29.7	52.9	16.6	50.1	42.1	33.3	27.5
	17	58.8	13.9	58.8	52.1	43.3	43.7	54.1	15.2	54.1	49.8	41.1	38.7	48.2	16.5	48.2	47.5	38.8	32.9
	15	52.9	13.7	52.9	52.9	48.2	42.3	50.6	14.9	50.6	50.6	46.9	41.1	45.3	16.3	45.3	45.3	44.7	38.9
(Nominal) 11500	23	71.4	14.9	45.4	35	24.7	-	67.7	16.3	44.2	33.8	23.4	-	61	18.1	42.1	31.7	21.3	-
	19	64.6	14.4	60.8	50.5	40.1	33.1	61*	15.7*	59.4	49*	38.6	31.7	54.9	17	54.9	45.8	36.4	29.5
	17	61	14.1	61	58	47.6	49.8	56.1	15.5	56.1	55.7	45.3	43	50	16.8	50	50	43	36.1
	15	54.9	14	54.9	54.9	53.5	46.6	52.5	15.2	52.5	52.5	52.3	45.3	47	16.6	47	47	47	43.1
(Maximum) 13500	23	73.2	15.1	49.3	37.3	25.4	-	69.5	16.5	48.1	36.1	24.1	-	62.6	18.3	46	34	22.1	-
	19	66.4	14.6	66.4	55	43	35	62.6	15.9	62.6	53.5	41.6	33.6	56.3	17.2	56.3	51.4	39.4	31.4
	17	62.6	14.3	62.6	62.6	51.6	56	57.8	15.7	57.8	57.6	49.4	47.2	51.3	17	51.3	51.3	47	39
	15	56.3	14.2	56.3	56.3	56.3	50.7	53.8	15.4	53.8	53.8	53.8	49.4	48.2	16.9	48.2	48.2	48.2	47.2

* Data in accordance with Eurovent Rooftop program certification conditions

PT: Total Power; PC: Power absorbed by the compressor
 WB: Wet-bulb temperature; TS: Dry bulb temperature.

1.11.3 ARC/ARG 075 Cooling capacities

Return air		Outdoor coil air temperature (TS)																	
Flow rate m³/h	TH °C	27 °C						35 °C						46 °C					
		PT kW	PC kW	Sensible power kW				PT kW	PC kW	Sensible power kW				PT kW	PC kW	Sensible power kW			
				TS inlet temp. in indoor coil						TS inlet temp. in indoor coil						TS inlet temp. in indoor coil			
		30	27	24	22	30	27	24	22	30	27	24	22	30	27	24	22		
(Minimum) 11500	23	81.2	19.5	49.3	38.7	28	-	77	21.3	47.8	37.2	26.6	-	69.4	23.6	45.4	34.8	24.2	-
	19	73.6	18.9	65.2	54.6	44	36.9	69.4	20.5	63.5	52.9	42.3	35.2	62.5	22.1	61	50.4	39.7	32.7
	17	69.4	18.5	69.4	62.6	51.7	52	63.8	20.3	63.8	59.8	49.1	46	56.9	21.9	56.9	56.9	46.4	39.3
	15	62.5	18.2	62.5	62.5	57.6	50.6	59.7	19.9	59.7	59.7	56.1	49.1	53.4	21.7	53.4	53.4	53.4	46.5
(Nominal) 13500	23	83.7	19.9	53.4	41.1	28.9	-	79.4	21.7	51.9	39.7	27.4	-	71.5	24	49.5	37.3	25	-
	19	75.8	19.2	71.6	59.3	47.1	38.9	71.5*	20.9*	70	57.7*	45.4	37.2	64.3	22.6	64.3	55.1	42.8	34.7
	17	71.5	18.8	71.5	68.2	56	58.1	65.8	20.7	65.8	65.6	53.3	50.3	58.6	22.4	58.6	58.6	50.6	42.4
	15	64.3	18.6	64.3	64.3	63	54.9	61.5	20.3	61.5	61.5	61.5	53.4	55	22.2	55	55	55	50.8
(Maximum) 16000	23	86	20.1	58.3	44.1	29.8	-	81.6	22	56.9	42.6	28.3	-	73.5	24.4	63.2	40.2	25.9	-
	19	78	19.5	78	65	50.8	41.3	73.5	21.2	73.5	63.3	49.1	39.6	66.2	22.9	54.4	60.8	46.5	37
	17	73.5	19.1	73.5	73.5	61	65.6	67.6	21	67.6	67.6	58.4	55.5	60.3	22.7	66.2	60.3	55.6	46.1
	15	66.2	18.9	66.2	66.2	66.2	60	63.2	20.6	63.2	63.2	63.2	58.5	56.6	22.5	60.3	56.6	56.6	55.8

* Data in accordance with Eurovent Rooftop program certification conditions

PT: Total Power; PC: Power absorbed by the compressor
 WB: Wet-bulb temperature; TS: Dry bulb temperature.

1.11.4 ARC/ARG 090 Cooling capacities

Return air		Outdoor coil air temperature (TS)																	
Flow rate m³/h	TH °C	27 °C						35 °C						46 °C					
		PT kW	PC kW	Sensible power kW				PT kW	PC kW	Sensible power kW				PT kW	PC kW	Sensible power kW			
				TS inlet temp. in indoor coil						TS inlet temp. in indoor coil						TS inlet temp. in indoor coil			
				30	27	24	22			30	27	24	22			30	27	24	22
(Mini- mum) 13000	23	94.5	19.5	57.8	45.2	32.6	-	89.7	21.3	56.2	43.6	31	-	80.8	23.6	53.4	40.8	28.2	-
	19	85.6	18.9	76.7	64.1	51.5	43.1	80.8	20.5	74.8	62.2	49.6	41.1	72.7	22.1	71.8	59.2	46.6	38.2
	17	80.8	18.5	80.8	73.3	60.7	56.2	74.3	20.3	74.3	70.3	57.7	51.4	66.3	21.9	66.3	66.3	54.5	46.1
	15	72.7	18.2	72.7	72.7	67.8	59.4	69.5	19.9	69.5	69.5	66.1	57.7	62.2	21.7	62.2	62.2	62.2	54.7
(Nominal) 16000	23	98.2	22.8	64.6	49.3	34	-	93.2	25	62.9	47.6	32.3	-	84	27.6	60.1	44.8	29.5	-
	19	89	22.1	87.3	71.9	56.6	46.4	84*	24*	84	70*	54.7	44.5	75.6	25.9	75.6	67	51.7	41.5
	17	84	21.6	84	83	67.7	63.8	77.3	23.8	77.3	77.3	64.6	57.5	68.9	25.7	68.9	68.9	61.4	51.2
	15	75.6	21.4	75.6	75.6	75.6	66.4	72.2	23.3	72.2	72.2	72.2	64.7	64.7	25.4	64.7	64.7	64.7	61.7
(Maxi- mum) 18000	23	100	23.1	68.9	51.8	34.7	-	95	25.3	67.3	50.2	33.1	-	85.6	27.9	64.5	47.4	30.3	-
	19	90.7	22.4	90.7	77	60	48.5	85.6	24.3	85.6	75	57.9	46.5	77	26.2	77	72	54.9	43.5
	17	85.6	21.9	85.6	85.6	72.2	68.9	78.8	24.1	78.8	78.7	69.1	61.4	70.2	26	70.2	70.2	65.9	54.5
	15	77	21.6	77	77	77	71	73.6	23.6	73.6	73.6	73.6	69.2	66	25.8	66	66	66	66

* Data in accordance with Eurovent Rooftop program certification conditions

PT: Total Power; PC: Power absorbed by the compressor
WB: Wet-bulb temperature; TS: Dry bulb temperature.

1.12 ARH/ARD output

1.12.1 ARH/ARD 045 Cooling capacities

Return air		Outdoor coil air temperature (TS)																	
Flow rate m³/h	TH °C	27 °C						35 °C						46 °C					
		PT kW	PC kW	Sensible power kW				PT kW	PC kW	Sensible power kW				PT kW	PC kW	Sensible power kW			
				TS inlet temp. in indoor coil						TS inlet temp. in indoor coil						TS inlet temp. in indoor coil			
				30	27	24	22			30	27	24	22			30	27	24	22
(Mini- mum) 7000	23	53.7	11.1	31.8	25.2	18.6	-	50.9	12.2	30.8	41.3	17.6	-	45.9	13.5	29.2	22.6	16	-
	19	48.6	10.8	41.7	35.1	28.5	24.1	45.9	11.7	40.6	24.2	27.4	23	41.3	12.6	39	32.3	25.7	21.3
	17	45.9	10.5	45.9	40	33.3	32.5	42.2	11.6	42.2	34	31.6	29.2	37.6	12.5	37.6	36.3	29.8	25.4
	15	41.3	10.4	41.3	41.3	36.9	32.5	39.5	11.3	39.5	38.2	36	31.6	35.3	12.4	35.3	35.3	34.2	29.8
(Nominal) 8500	23	55.7	11.3	34.9	27.1	19.2	-	52.8	12.4	33.9	26.1	18.3	-	47.6	13.7	32.3	24.5	16.6	-
	19	50.5	10.9	46.6	38.8	30.9	25.7	47.6*	11.9*	45.5	37.6*	29.8	24.6	42.8	12.9	42.8	35.9	28.1	22.9
	17	47.6	10.7	47.6	44.5	36.6	36.8	43.8	11.8	43.8	42.7	34.9	32.4	39	12.7	39	39	33	27.8
	15	42.8	10.6	42.8	42.8	41.1	35.9	40.9	11.5	40.9	40.9	40.1	34.9	36.7	12.6	36.7	36.7	36.7	33.1
(Maxi- mum) 10000	23	57.25	11.5	37.9	28.9	19.8	-	54.3	12.6	37	27.9	18.8	-	48.9	213.9	35.3	26.3	17.2	-
	19	51.8	11.1	51.3	42.2	33.2	27.2	48.9	12.1	48.9	41.1	32.1	26	44	13.1	44	39.4	30.3	24.3
	17	48.9	10.9	48.9	48.8	39.7	41.3	45	12	45	45	37.9	35.6	40.1	12.9	40.1	40.1	36.1	30
	15	44	10.8	44	44	44	39	42.1	11.7	42.1	42.1	42.1	38	37.6	12.8	37.6	37.6	37.6	36.2

* Data in accordance with Eurovent Rooftop program certification conditions

PT: Total Power; PC: Power absorbed by the compressor
WB: Wet-bulb temperature; TS: Dry bulb temperature.

1.12 ARH/ARD output

1.12.2 ARH/ARD 060 Cooling capacities

Return air		Outdoor coil air temperature (TS)																	
Flow rate m³/h	TH °C	27 °C						35 °C						46 °C					
		PT kW	PC kW	Sensible power kW				PT kW	PC kW	Sensible power kW				PT kW	PC kW	Sensible power kW			
				TS inlet temp. in indoor coil						TS inlet temp. in indoor coil						TS inlet temp. in indoor coil			
				30	27	24	22			30	27	24	22			30	27	24	22
(Minimum) 9500	23	69.8	14.2	42.2	33.1	24.1	-	66.3	15.5	40.9	31.9	22.8	-	59.7	17.1	38.8	29.8	20.7	-
	19	63.2	13.7	55.7	46.7	37.7	31.6	59.7	14.9	54.3	45.2	36.3	30.2	53.7	16.1	52.1	43	34	28
	17	59.7	13.4	59.7	53.3	44.3	42.5	54.9	14.8	54.9	51	42	38.3	48.9	15.9	49	48.7	36.7	33.6
	15	53.7	13.3	53.7	53.7	49.3	43.3	51.3	14.5	51.3	51.3	48	42	46	15.8	46	46	45.8	39.8
(Nominal) 11500	23	72.4	14.4	46.5	35.8	25	-	68.7	15.8	45.2	34.5	23.8	-	61.9	17.5	43.2	32.4	21.7	-
	19	65.6	14	62.4	51.7	41	33.8	61.9*	15.2*	61	50.3*	39.5	32.4	55.7	16.4	55.7	48	37.3	30.1
	17	61.9	13.7	61.9	59.5	48.7	48.1	56.9	15	56.9	56.9	46.5	42.5	50.8	16.3	50.8	50.8	44.1	36.9
	15	55.7	13.5	55.7	55.7	55	47.8	53.2	14.7	53.2	53.2	53.2	46.5	47.7	16.1	47.7	47.7	47.7	44.2
(Maximum) 13500	23	74.4	14.6	50.7	38.2	25.8	-	70.6	16	49.4	37	24.6	-	63.6	17.7	47.3	34.9	22.5	-
	19	67.4	14.2	67.4	56.5	44.1	35.8	63.6	15.4	63.6	55.1	42.6	34.3	57.2	16.6	57.2	52.8	40.2	32.1
	17	63.6	13.9	63.6	63.6	53	53	58.5	15.2	58.5	58.5	50.8	46.6	52.1	16.5	52.1	52.1	48.3	40
	15	57.2	13.7	57.2	57.2	57.2	52.1	54.7	14.9	54.7	54.7	54.7	50.8	49	16.3	49	49	49	48.6

* Data in accordance with Eurovent Rooftop program certification conditions

PT: Total Power; PC: Power absorbed by the compressor
 WB: Wet-bulb temperature; TS: Dry bulb temperature.

1.12.3 ARH/ARD 075 Cooling capacities

Return air		Outdoor coil air temperature (TS)																	
Flow rate m³/h	TH °C	27 °C						35 °C						46 °C					
		PT kW	PC kW	Sensible power kW				PT kW	PC kW	Sensible power kW				PT kW	PC kW	Sensible power kW			
				TS inlet temp. in indoor coil						TS inlet temp. in indoor coil						TS inlet temp. in indoor coil			
				30	27	24	22			30	27	24	22			30	27	24	22
(Minimum) 11500	23	81.1	19.6	49.2	38.6	28	-	76.9	21.4	47.8	37.2	26.6	-	69.3	23.7	45.4	34.8	24.1	-
	19	73.5	19	65.2	54.6	43.9	36.8	69.3	20.6	63.5	52.9	42.3	35.2	62.4	22.2	61	50.3	39.7	32.6
	17	69.3	18.5	69.3	62.2	51.7	52	63.8	20.4	63.8	59.7	49.1	46	56.8	22	56.8	56.8	46.3	39.3
	15	62.4	18.3	62.4	62.4	57.6	50.5	59.6	20	59.6	59.6	53.1	49.1	53.3	21.8	53.3	53.3	53.3	46.5
(Nominal) 13500	23	83.5	19.9	53.3	41.1	28.9	-	79.3	21.7	51.9	39.6	27.4	-	71.4	24	49.5	37.2	25	-
	19	75.7	19.2	71.6	59.3	47.1	38.9	71.4*	20.9*	69.9	57.6*	45.4	37.2	64.3	22.6	64.3	55.1	42.8	34.7
	17	71.4	18.8	71.4	68.2	55.9	58	65.7	20.7	65.7	65.5	53.3	50.3	58.5	22.4	58.5	58.5	50.6	42.4
	15	64.2	18.6	64.2	64.2	63	54.8	61.4	20.3	61.4	61.4	61.4	53.3	55	22.2	55	55	55	50.7
(Maximum) 16000	23	85.9	20.1	58.3	44	29.8	-	81.5	22	56.8	42.6	28.3	-	73.4	24.4	54.4	40.2	25.9	-
	19	77.8	19.5	77.8	65	50.7	41.3	73.4	21.2	73.4	63.3	49	39.6	66.1	22.9	66.1	60.7	46.5	37
	17	73.4	19.1	73.4	73.4	61	60.6	67.5	21	67.5	67.5	58.4	55.5	60.2	22.7	60.2	60.2	55.6	46.1
	15	66.1	18.9	66.1	66.1	66.1	60	63.1	20.6	63.1	63.1	63.1	58.4	56.5	22.5	56.5	56.5	56.5	55.8

* Data in accordance with Eurovent Rooftop program certification conditions

PT: Total Power; PC: Power absorbed by the compressor
 WB: Wet-bulb temperature; TS: Dry bulb temperature.

1.12.4 ARH/ARD 090 Cooling capacities

Return air		Outdoor coil air temperature (TS)																	
Flow rate m³/h	TH °C	27 °C								35 °C				46 °C					
		PT kW	PC kW	Sensible power kW				PT kW	PC kW	Sensible power kW				PT kW	PC kW	Sensible power kW			
				TS inlet temp. in indoor coil						TS inlet temp. in indoor coil						TS inlet temp. in indoor coil			
				30	27	24	22			30	27	24	22			30	27	24	22
(Minimum) 13000	23	93.8	22.9	57.6	45	32.4	-	89	25.1	55.9	43.3	30.7	-	80.2	27.7	53.2	40.5	28	-
	19	85	22.2	76.5	63.9	51.3	42.9	80.2	24.1	74.5	61.9	49.4	41	72.2	26	71.6	59	46.4	38
	17	80.2	21.7	80.2	73	60.4	56	73.8	23.9	73.8	70	57.4	51.1	65.8	25.8	65.8	65.8	54.3	46
	15	72.2	21.4	72.2	72.2	67.5	59.1	69	23.4	69	69	65.8	57.4	61.7	25.5	61.7	61.7	61.7	54.5
(Nominal) 16000	23	97.6	23.4	64.4	49.1	33.8	-	92.6	25.6	62.7	47.4	32.1	-	83.4	28.3	60	44.6	29.3	-
	19	88.4	22.6	87	71.7	56.4	46.2	83.4*	24.6*	83.4	69.7*	54.5	44.2	75.1	26.6	75.1	66.8	51.5	41.3
	17	83.4	22.1	83.4	82.7	67.4	63.6	76.7	24.4	76.7	76.7	64.4	57.3	68.4	26.3	68.4	68.4	61.2	51
	15	75.1	21.9	75.1	75.1	75.1	66.2	71.7	23.9	71.7	71.7	71.7	64.5	64.2	26.1	64.2	64.2	64.2	61.5
(Maximum) 18000	23	99.5	23.7	68.7	51.6	34.5	-	94.3	25.9	67	50	32.9	-	85	28.6	64.2	47.2	30.1	-
	19	90.1	22.9	90.1	76.7	59.6	48.2	85	24.9	85	74.8	57.7	46.3	76.5	26.9	76.5	71.8	54.7	43.3
	17	85	22.4	85	85	71.9	68.6	78.2	24.7	78.2	78.2	68.9	61.2	69.7	26.6	69.7	69.7	65.7	54.3
	15	76.5	22.2	76.5	76.5	76.5	70.7	73.1	24.2	73.1	73.1	73.1	68.8	65.5	26.4	65.5	65.5	65.5	65.5

* Data in accordance with Eurovent Rooftop program certification conditions

PT: Total Power; PC: Power absorbed by the compressor

WB: Wet-bulb temperature; TS: Dry bulb temperature.

1.12.5 ARH/ARD 045 Thermodynamic heat capacity

Flow rate m³/h	Return air DB °C	Outdoor air temperature TS °C															
		-10		-5		0		5		7		10		15		20	
		PT	PC	PT	PC	PT	PC	PT	PC	PT	PC	PT	PC	PT	PC	PT	PC
(Minimum) 7000	14	30.2	10.2	34.1	10.7	38.6	11.1	43.5	11.4	45.6	11.9	48.9	12.3	54.8	13.2	61.1	13.7
	17	29.8	11.1	33.7	11.6	38.1	12.1	43	12.3	45.1	12.9	48.3	13.4	54.2	14.3	60.4	14.9
	20	29.5	11.4	33.3	11.8	37.7	12.3	42.5	12.6	44.6	13.2	47.8	13.7	53.6	14.7	59.7	15.2
	23	29.1	12.1	32.9	12.6	37.2	13.2	42	13.5	44	14.1	47.2	14.6	52.9	15.7	59	16.2
	25	28.9	12.5	32.7	13	37	13.6	41.7	13.9	43.7	14.5	46.9	15	52.6	16.1	58.6	16.7
(Nominal) 8500	14	30.6	9.9	34.6	10.3	39.2	10.8	44.2	11	46.3	11.6	49.6	12	55.6	12.8	62	13.3
	17	30.2	10.8	34.2	11.2	38.7	11.7	43.6	12	45.7	12.5	49	13	55	13.9	61.3	14.4
	20	29.9	11	33.8	11.5	38.2	12	43.1	12.2	45.2*	12.8*	48.4	13.2	54.3	14.21	60.6	14.7
	23	29.5	11.8	33.3	12.3	37.7	12.8	42.6	13.1	44.6	13.7	47.8	14.2	53.6	15.2	59.8	15.8
	25	29.3	12.1	33.1	12.6	37.5	13.2	42.3	13.4	44.3	14.1	47.5	14.6	53.3	15.6	59.4	16.2
(Maximum) 10000	14	30.9	9.7	34.9	10.1	39.5	10.5	44.6	10.7	46.7	11.3	50.1	11.6	56.2	12.5	62.6	12.9
	17	30.5	10.5	34.5	10.9	39.1	11.4	44.1	11.6	46.2	12.2	49.5	12.6	55.5	13.5	61.9	14
	20	30.2	10.7	34.1	11.2	38.6	11.7	43.5	11.9	45.6	12.5	49	12.9	54.9	13.8	61.2	14.3
	23	29.8	11.5	33.7	11.9	38.1	12.5	43	12.7	45.1	13.3	48.3	13.8	54.2	14.8	60.3	15.3
	25	29.6	11.8	33.4	12.3	37.9	12.8	42.7	13.1	44.8	13.7	48	14.2	53.8	15.2	60	15.8

* Data in accordance with Eurovent Rooftop program certification conditions

PT: Total Power; PC: Power absorbed by the compressor

WB: Wet-bulb temperature; TS: Dry bulb temperature.

1.12 ARH/ARD output

1.12.6 ARH/ARD 060 Thermodynamic heat capacity

Flow rate m³/h	Return air DB °C	Outdoor air temperature TS °C															
		-10		-5		0		5		7		10		15		20	
		PT	PC	PT	PC	PT	PC	PT	PC	PT	PC	PT	PC	PT	PC	PT	PC
(Minimum) 9500	14	38.7	11.4	43.7	11.8	49.5	12.4	55.9	12.6	58.6	13.2	62.8	13.7	70.4	14.7	78.5	15.2
	17	38.2	12.3	43.2	12.8	49	13.4	55.25	13.7	57.9	14.3	62	14.8	69.6	15.9	77.6	16.5
	20	37.8	12.6	42.7	13.1	48.4	13.7	54.6	14	57.2	14.7	61.3	15.2	68.7	16.3	76.6	16.9
	23	37.3	13.5	42.2	14	47.8	14.7	53.8	15	56.4	15.7	60.5	16.2	67.8	17.4	75.6	18
	25	37.1	13.9	41.9	14.4	47.5	15.1	53.5	15.4	56.1	16.1	60.1	16.7	67.4	17.9	75.2	18.5
(Nominal) 11500	14	39.3	11	44.4	11.5	50.2	12	56.7	12.2	59.4	12.8	63.7	13.3	71.4	14.2	79.6	14.7
	17	38.8	11.9	43.8	12.4	49.7	13	56	13.3	58.7	13.9	63	14.4	70.6	15.4	78.7	16
	20	38.3	12.2	43.2	12.7	49.1	13.3	55.3	13.6	58*	14.2*	62.2	14.7	69.7	15.8	77.7	16.3
	23	37.8	13.1	42.8	13.6	48.4	14.2	54.6	14.5	57.2	15.2	61.4	15.7	68.8	16.9	76.7	17.5
	25	37.6	13.4	42.5	14	48.1	14.6	54.3	14.9	56.9	15.6	61	16.2	68.4	17.3	76.2	18
(Maximum) 13500	14	39.7	10.7	44.8	11.2	50.7	11.7	57.2	11.9	60	12.5	64.3	12.9	72.1	13.9	80.4	14.4
	17	39.2	11.6	44.3	12.1	50.2	12.6	56.6	12.9	59.3	13.5	63.6	14	71.3	15	79.4	15.6
	20	38.7	11.9	43.8	12.4	49.6	12.9	55.9	13.2	58.6	13.8	62.8	14.3	70.4	15.3	78.5	15.9
	23	38.2	12.7	43.2	13.2	48.9	13.8	55.2	14.1	57.8	14.8	62	15.3	69.5	16.4	77.5	17
	25	38	13.1	43	13.6	48.6	14.2	54.8	14.5	57.5	15.2	61.6	15.7	69.1	16.9	77	17.5

* Data in accordance with Eurovent Rooftop program certification conditions

PT: Total Power; PC: Power absorbed by the compressor
 WB: Wet-bulb temperature; TS: Dry bulb temperature.

1.12.7 ARH/ARD 075 Thermodynamic heat capacity

Flow rate m³/h	Return air DB °C	Outdoor air temperature TS °C															
		-10		-5		0		5		7		10		15		20	
		PT	PC	PT	PC	PT	PC	PT	PC	PT	PC	PT	PC	PT	PC	PT	PC
(Minimum) 11500	14	47.9	15.9	54.1	16.5	61.2	17.2	69.1	17.6	72.4	18.4	77.6	19.1	87	20.5	97	21.2
	17	47.3	17.2	53.4	17.9	60.5	18.7	68.3	19.1	71.5	20	76.7	20.7	86	22.2	95.9	23
	20	46.7	17.5	52.8	18.3	59.8	19.1	67.4	19.5	70.7	20.4	75.8	21.1	85	22.7	94.7	23.5
	23	46.1	18.8	52.1	19.6	59	20.4	66.6	20.9	69.8	21.8	74.8	22.6	83.9	24.3	93.5	25.1
	25	45.8	19.3	51.8	20.1	58.7	21	66.2	21.5	69.3	22.5	74.3	23.3	83.4	24.9	93	25.8
(Nominal) 13500	14	48.5	15.4	54.8	16	62.1	16.7	70	17.1	73.4	17.9	78.7	18.5	88.3	19.8	98.4	20.6
	17	48	16.6	54.2	17.3	61.4	18.1	69.2	18.5	72.6	19.4	77.8	20	87.2	21.5	97.2	22.2
	20	47.4	17	53.6	17.7	60.6	18.5	68.4	18.9	71.7*	19.8*	76.9	20.5	86.25	22	96.1	22.8
	23	46.8	18.2	52.9	19	60	19.8	67.5	20.2	70.8	21.2	75.9	21.9	85.1	23.5	95	24.4
	25	46.5	18.7	52.5	19.5	59.5	20.4	67.1	20.8	70.3	21.8	75.4	22.5	84.5	24.1	94.2	25
(Maximum) 16000	14	49	15	55.4	15.6	62.7	16.3	70.7	16.6	74.2	17.4	79.5	18	89.1	19.3	99.4	20
	17	48.4	16.2	54.7	16.9	62	17.6	69.9	18	73.3	18.9	78.6	19.5	88.1	20.9	98.2	21.7
	20	47.9	16.6	54.1	17.3	62.3	18	69.1	18.4	72.4	19.3	77.6	20	87	21.4	97	22.2
	23	47.2	17.7	53.4	18.5	60.5	19.3	68.2	19.7	71.5	20.6	76.6	21.4	85.9	22.9	95.8	23.7
	25	47	18.2	53.1	19	60.1	19.8	67.8	20.3	71	21.2	76.2	22	85.4	23.5	95.2	24.4

* Data in accordance with Eurovent Rooftop program certification conditions

PT: Total Power; PC: Power absorbed by the compressor
 WB: Wet-bulb temperature; TS: Dry bulb temperature.

1.12.8 ARH/ARD 090 Thermodynamic heat capacity

Flow rate m ³ /h	Return air DB °C	Outdoor air temperature TS °C															
		-10		-5		0		5		7		10		15		20	
		PT	PC	PT	PC	PT	PC	PT	PC	PT	PC	PT	PC	PT	PC	PT	PC
(Minimum) 13000	14	57.7	18.4	65.2	19.2	73.9	20	83.3	20.5	87.3	21.4	93.6	22.2	105	23.8	117	24.6
	17	57.1	20	64.5	20.8	73	21.7	82.3	22.2	86.3	23.2	92.5	24	103.7	25.8	115.7	27
	20	56.4	20.4	63.7	21.2	72.1	22.2	81.4	22.7	85.3	23.7	91.4	24.6	102.5	26.3	114.3	27.3
	23	55.6	21.8	62.9	22.7	71.2	23.7	80.3	24.3	84.2	25.4	90.2	26.3	101.2	28.2	112.8	29.2
	25	55.3	22.5	62.5	23.4	70.8	24.4	79.8	24.9	83.7	26.1	89.7	27	100.6	29	112.1	30
(Nominal) 16000	14	58.5	17.9	66.2	18.6	74.9	19.4	84.5	19.8	88.6	20.8	95	21.5	106.5	23	118.7	23.9
	17	57.9	19.3	65.4	20.1	74	21	83.5	21.5	87.5	22.5	93.8	23.3	105.2	25	117.3	25.9
	20	57.2	19.8	64.6	20.6	73.2	21.5	82.5	22	86.5*	23*	92.7	23.8	104	25.5	116	26.4
	23	56.4	21.2	63.8	22	72.2	23	81.4	23.5	85.4	24.6	91.5	25.5	102.6	27.3	114.4	28.3
	25	56.1	21.8	63.4	22.6	71.8	23.7	81	24.2	84.9	25.3	91	26.2	102	28.1	113.7	29.1
(Maximum) 18000	14	59.1	17.4	66.8	18.1	75.7	18.9	85.3	19.3	89.5	20.2	96	20.9	107.5	22.4	119.9	23.3
	17	58.4	18.8	66	19.6	74.8	20.5	88.4	20.9	88.4	21.9	94.8	22.7	106.3	24.3	118.5	25.2
	20	57.7	19.3	65.3	20	73.9	20.9	83.3	21.4	87.4	22.4	93.7	23.2	105	24.8	117	25.8
	23	57	20.6	64.4	21.4	73	22.4	82.3	22.9	86.2	24	92.4	24.8	103.6	26.6	115.5	27.6
	25	56.7	21.2	64	22	72.5	23	81.8	23.5	85.7	24.6	91.9	25.5	103	27.3	114.8	28.3

* Data in accordance with Eurovent Rooftop program certification conditions

PT: Total Power; PC: Power absorbed by the compressor

WB: Wet-bulb temperature; TS: Dry bulb temperature.

1.13 Indoor fan

1.13.1 Features table

Model	Fan kit	Motor (1)		Motor pulley (adjustable)		Fan pulley (fixed)		Belt		
		kW	Type of casing	∅ pulley (mm)	∅ shaft (mm)	∅ pulley (mm)	∅ shaft (mm)	Length (mm)	Ref.	Qty.
045	Standard	3	100	109-135	28	236	25	1840	BX71	1
	Option HPD 4 kW	4	112	109-135	28	190	25	1740	BX67	1
060	Standard	4	112	124-150	28	236	25	2040	BX79	1
	Option HPD 5.5 kW	5.5	132	147-178	38	236	25	2040	BX79	1
075	Standard	5.5	132	124-150	38	236	25	2040	BX79	1
	Option HPD 7.5 kW	7.5	132	147-178	38	236	25	2123	BX82	1
090	Standard	7.5	132	139-173	38	250	35	2040	BX79	2
	Option HPD 11 kW	11	160	152-190	42	250	35	2400	BX93	2

(1) Motor with IP55 protection rating, Class F insulation and IE3 efficiency class (IEC 60034-30-1).

Inside fan output tables for determining the motor pulley adjustment and the type of drive needed for the installation.

1.13.2 Considerations when consulting the output tables

Indoor fan output tables

For units with 0% outdoor air and 100% return air, dry indoor coil, and standard G4 filters.

1.13 Indoor fan

**CAUTION**

Before consulting the tables, add secure drops to the pressure required for the installation due to:

- heat pump (models ARH/ARD-045 and 060)
- Gas heating (ARG/ARD Models)
- vertical supply and return and
- accessories included in the unit, when appropriate. See [Pressure drop of options/accessories, gas heating and vertical ducts.](#), see on page 27.

The motor pulleys come adjusted to an opening of 4 turns. See [Maintenance tasks performed by specialised personnel](#), see on page 40 for the belt adjustment and tightening procedure.

**CAUTION**

- Before commissioning the installation, but after balancing the air distribution in the building, the supply air flow should be checked.
- With clean filters the indoor fan should not exceed a vacuum of -200 Pa in suction.

1.13.3 Output table for indoor fan, model ARC-045, applications with side ducts, standard drive motor 3 kW

Motor pulley opening adjustment (no. of turns)	Air flow rate m ³ /h									
	7000		8000		8500		9000		10000	
	SPA	kW	SPA	kW	SPA	kW	SPA	kW	SPA	kW
0	244	1,9	203	2,1	182	2,2	160	2,4	114	2,7
1	220	1,8	185	2,0	155	2,1	134	2,3	85	2,6
2	194	1,7	167	1,9	130	2	106	2,1	53	2,4
3	174	1,6	138	1,8	106	1,9	80	2	-	-
4	152	1,4	108	1,6	82	1,8	54	1,9	-	-
5	122	1,3	80	1,5	52	1,6	-	-	-	-
6	94	1,1	52	1,4	-	-	-	-	-	-

SPA: Static pressure available (Pa).

1.13.4 Output table for indoor fan, model ARC-045, applications with side ducts, optional HPD drive motor 4 kW

Motor pulley opening adjustment (no. of turns)	Air flow rate m ³ /h									
	7000		8000		8500		9000		10000	
	SPA	kW	SPA	kW	SPA	kW	SPA	kW	SPA	kW
0	425	2,8	392	3,2	368	3,3	346	3,5	298	3,9
1	380	2,8	342	3,1	320	3,3	297	3,5	244	3,8
2	338	2,7	294	3,0	268	3,2	247	3,4	187	3,7
3	310	2,6	270	2,9	246	3,0	225	3,2	168	3,5
4	280	2,4	248	2,7	224	2,8	202	3,0	147	3,3
5	245	2,3	212	2,6	188	2,7	165	2,9	110	3,2
6	212	2,2	175	2,5	150	2,6	126	2,7	70	3,0

SPA: Static pressure available (Pa).

1.13.5 Output table for indoor fan, model ARC-060, applications with side ducts, standard drive motor 4 kW

Motor pulley opening adjustment (no. of turns)	Air flow rate m ³ /h									
	9500		10500		11500		12500		13500	
	SPA	kW	SPA	kW	SPA	kW	SPA	kW	SPA	kW
0	340	3,2	308	3,5	270	3,9	230*	4,3*	176*	4,5*
1	310	3,1	277	3,4	240	3,7	197*	4,1*	146*	4,4*
2	280	2,9	248	3,2	210	3,5	163	3,9	115*	4,3*
3	250	2,7	220	3,0	180	3,3	147	3,7	88*	4,1*
4	218	2,5	188	2,8	152	3,1	130	3,5	60	3,9
5	190	2,3	162	2,6	123	3,0	90	3,4	30	3,7
6	160	2,1	134	2,4	92	2,8	50	3,2	-	-

SPA: Static pressure available (Pa).

* Zone outside of range

1.13.6 Output table for indoor fan, model ARC-060, applications with side ducts, optional HPD drive motor 5.5 kW

Motor pulley opening adjustment (no. of turns)	Air flow rate m ³ /h									
	9500		10500		11500		12500		13500	
	SPA	kW	SPA	kW	SPA	kW	SPA	kW	SPA	kW
0	505	3,7	472	4,1	430	4,6	390	5,0	347*	5,7*
1	475	3,5	440	3,9	400	4,3	357	4,8	310	5,5
2	447	3,4	410	3,5	370	4,2	323	4,6	273	5,2
3	418	3,2	380	3,4	340	3,9	292	4,4	245	4,9
4	387	3,0	350	3,2	307	3,7	260	4,1	215	4,5
5	340	2,9	306	3,1	267	3,5	223	3,9	178	4,3
6	295	2,7	262	3,0	227	3,3	185	3,7	140	4,1

SPA: Static pressure available (Pa).

* Zone outside of range

1.13.7 Output table for indoor fan, model ARC-075, applications with side ducts, standard drive motor 5.5 kW

Motor pulley opening adjustment (no. of turns)	Air flow rate m ³ /h											
	11500		12500		13500		14500		15000		16000	
	SPA	kW	SPA	kW	SPA	kW	SPA	kW	SPA	kW	SPA	kW
0	335	3,9	294	4,3	240	4,7	195	5,1	143	5,4	105*	5,8*
1	280	3,6	240	4,0	190	4,4	140	4,8	108	5,1	45	5,5
2	226	3,3	187	3,8	140	4,1	85	4,5	50	4,8	-	-
3	190	3,1	148	3,5	104	3,8	25	4,2	-	-	-	-
4	155	2,9	116	3,2	43	3,6	-	-	-	-	-	-
5	124	2,8	78	3,1	-	-	-	-	-	-	-	-
6	97	2,7	40	3,0	-	-	-	-	-	-	-	-

SPA: Static pressure available (Pa).

* Zone outside of range

1.13 Indoor fan

1.13.8 Output table for indoor fan, model ARC/ARH-075, applications with side ducts, optional HPD drive motor 7.5 kW

Motor pulley opening adjustment (no. of turns)	Air flow rate m³/h											
	11500		12500		13500		14500		15000		16000	
	SPA	KW	SPA	KW	SPA	KW	SPA	KW	SPA	KW	SPA	KW
0	-*	-*	-*	-*	-*	-*	-*	-*	625*	8,2*	540*	8,8*
1	-*	-*	-*	-*	-*	-*	595	7,4	564*	8,0*	508*	8,6*
2	660	5,1	630	5,9	588	6,5	540	7,2	512*	7,7*	460*	8,4*
3	610	4,9	565	5,5	524	6,1	478	6,8	450	7,3	400*	7,9*
4	550	4,7	510	5,2	465	5,8	420	6,5	394	6,9	338	7,5
5	495	4,5	450	5,0	408	5,5	362	6,1	330	6,5	277	7,0
6	440	4,3	400	4,8	352	5,3	305	5,8	273	6,1	220	6,6

* Zone outside of range

1.13.9 Output table for indoor fan, model ARC/ARH-090, applications with side ducts, standard drive motor 7.5 kW

Motor pulley opening adjustment (no. of turns)	Airflow rate m³/h											
	13000		14000		15000		16000		17000		18000	
	SPA	KW	SPA	KW	SPA	KW	SPA	KW	SPA	KW	SPA	KW
0	480	6,9	420	7,5	368	7,9	314**	8,3**	250**	9,1**	180*	9,8*
1	435	6,5	380	7,1	322	7,5	265**	8,0**	205**	8,7**	136*	9,5*
2	390	6,1	335	6,6	276	7,0	218**	7,7**	160**	8,3**	93**	9,1**
3	352	5,6	298	6,1	245	6,5	184	7,1	120**	7,8**	55**	8,5**
4	316	5,1	262	5,5	212	6,0	150	6,6	78	7,3	-	-
5	270	4,9	215	5,3	167	5,8	105	6,4	35	7,0	-	-
6	225	4,7	172	5,1	120	5,7	60	6,2	-	-	-	-

SPA: Static pressure available (Pa).

* Zone out of range (see HPD option 11 kW)

1.13.10 Output table for indoor fan, model ARC/ARH-090, applications with side ducts, optional HPD drive motor 11 kW

Motor pulley opening adjustment (no. of turns)	Air flow rate m³/h											
	13000		14000		15000		16000		17000		18000	
	SPA	KW	SPA	KW	SPA	KW	SPA	KW	SPA	KW	SPA	KW
0	-*	-*	-*	-*	535	8,4	465	9,0	398	9,7	330	10,5
1	610	7,5	550	7,9	472	8,3	408	8,9	343	9,6	275	10,4
2	540	7,3	474	7,7	412	8,1	352	8,7	288	9,4	220	10,2
3	494	6,9	434	7,4	375	7,9	315	8,4	254	9,1	185	9,9
4	447	6,5	395	7,0	338	7,6	278	8,1	220	8,8	150	9,6
5	396	6,2	344	6,7	285	7,2	227	7,8	168	8,4	98	9,2
6	345	5,9	292	6,3	236	6,8	176	7,4	115	8,0	45	8,7

SPA: Static pressure available (Pa).

* Zone outside of range

1.14 Pressure drop of options/accessories, gas heating and vertical ducts.

Model	m ³ /h (x 1000)	Pressure drop (Pa)												
		7	8	9	10	11	12	13	14	15	16	17	18	
Gas heating	ARG/ARD	18	20	24	30	37	45	53	60	70	80	90	100	
Heat pump	ARH/ARD 045	8	13	14	17									
	ARH/ARD 060			18	22	26	30	34	36					
Vertical supply	045/060	28	32	38	45	56	70	82	93					
	075/090					28	30	35	45	57	85	125	165	
Vertical return		12	12	12	12	12	12	12	12	12	12	12	12	
Option or accessory	Economiser/Motorised damper	7	9	11	13	16	19	22	25	29	33	37	43	
	Heating element kW	12-25	20	28	36	44	56	68	80	92	110	125	144	170
		37	28	37	46	56	70	85	100	114	130	150	172	194
		50	45	60	75	92	110	130	155	180	210	240	274	310
	Water coil		35	43	52	63	76	90	104	119	133	147	163	190
	Air filters F6	045/060	50	55	65	70	75	87	100	114				
		075					55	65	68	70	82	87		
		090							78	80	92	97	110	118
	Air filters F7	045/060	67	75	85	95	105	115	125	135				
		075					75	85	90	95	107	115		
090								100	105	117	125	135	145	

1.15 Instructions for installation and connection of the unit

1.15.1 Characteristics of the location

The location of the unit must be studied to ensure a completely satisfactory installation. To do so, the environmental conditions of the area where the unit is to be installed must be taken into account.

Furthermore, the normal weather conditions should be instrumental in determining the best position of the unit and the hoods, screens or covers required to ensure its correct working order.

If possible, in warm zones like the southern Europe, the unit should be located on the north or east side of the building or property.

The location chosen for the unit must provide the condenser with an unlimited air supply.

As well as the technical data given in this document and any others that are applicable, please bear in mind that the unit has been designed for outdoors installation only.

Where the unit is to be installed at ground level, refer to section [Specifications for the foundation or anchoring of the unit](#), see on page 28.

Where the unit is to be installed on the roof of a building or property, make sure that the roof structure can support the weight of the unit plus that of any optional equipment and/or accessories to be fitted.

The unit must be installed on a specific mounting base or on a frame of appropriate steel angles. There are optional mounting bases available (Roof-curb).

Regardless, keep the level tolerance at maximum 10 mm all along the length and width of the unit.

If the unit is to be installed on a base or on a special angle frame that is not the standard Roof-curb, gaskets should be applied to all surfaces that are touching the bottom of the unit.

If it is preferred to place the unit on shock absorbers, this should be done as described in [Installation on shock absorbers](#), see on page 29.

Special instructions for locations where there is regular snowfall or with ambient temperatures of close to 0°C or less

In areas where there is regular or sporadic snow, the unit should be elevated above the ground or roof where it is installed. The height should be enough to prevent the unit, the condenser and evaporator air inlets and the access to the unit panels from becoming blocked by accumulated snow.

1.15 Instructions for installation and connection of the unit

Protection against ice

In areas where the temperature can be 0°C or less, there should be some kind of additional protection to prevent the water contained in the condensate drain pipe from freezing.

Use a wire heating element in the drain trap as well as in the drain, where applicable.

In heat pumps, also use cord resistors in the outdoor coil tray to prevent any ice from accumulating.

Special instruction for locations with high ambient temperatures

In areas where the ambient temperature is over 43°C, the unit must not be located in direct sunlight and, therefore a specific sunshade will be required.

The installation of a special sunshade over the unit must not affect the air flow required by the unit to work correctly. Check the minimum clearance required *Connections for supply and return side ducts*, see on page 12.

1.15.2 Characteristics of the facility where the unit will be installed

The air duct installation where the unit is to be installed must be formed by a closed return duct system. The additional installation of economisers or outdoor air intakes is not excluded.

To reduce operating noise, the supply and return air duct connections on the unit must be made using flexible joints.

The supply and return air duct systems must be designed for the air flow requirements of the installation. The ducts should not be sized based on the supply and return air connection sizes of the unit.

Duct covers

Units are shipped with side and lower duct openings covered. See section *Connections for supply and return side ducts*, see on page 12.

1.15.3 Specifications for the foundation or anchoring of the unit

Where the unit is to be installed at ground level, the characteristics of the ground it will sit on must be taken into account.

Characteristics, such as acceptable surface firmness, must be suitable for the foundation the unit requires.

The unit should be placed on a level concrete slab at least 100 mm thick.

The length and width of the slab must be at least 150 mm more than the base rails on the unit.



CAUTION

Do not attach the unit to the foundations of the building.

1.15.4 Installation on shock absorbers

The beams on the base of the unit have drill holes in order to mount shock absorber supports, distributed according to the figure.

The kit is supplied with the eight shock absorbers and the necessary bolts for mounting, for the installation of the unit in its location.

With this weight distribution and type of shock absorber a 91% insulation level is achieved, according to the measurements taken in vibration testing.

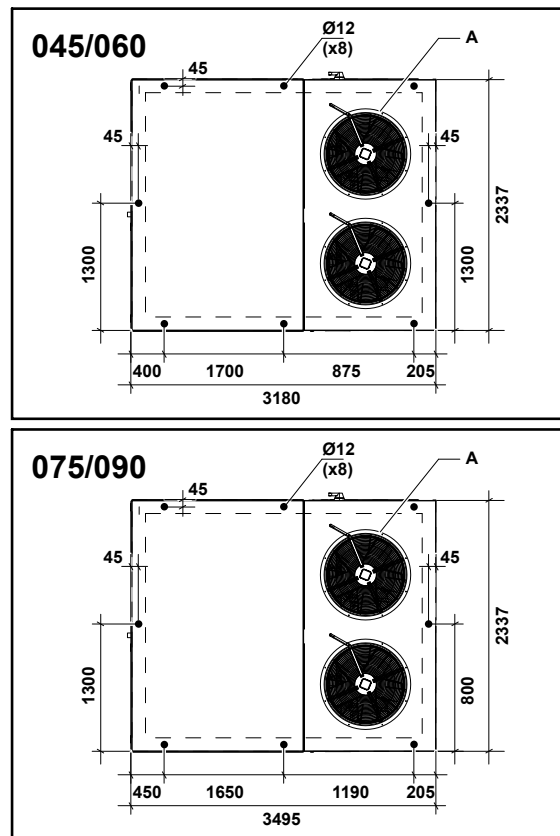

The location of the support points has been studied in order to achieve an equal distribution of weight in each shock absorber, as shown in the table:

	Approximate weight on each support point [kg] (units without options or accessories)			
Model	045	060	075	090
ARC	113	118	140	143
ARH	117	123	143	153
ARG	126	132	154	157
ARD	130	137	157	167

1.15.5 Characteristics of utility provider connections

In general, the different connections required by the unit are made following the shortest route possible. Under no circumstances may any local or national regulations be contravened when performing the preparatory work for service connections.



NOTE

For further information on this subject, always keep the current regulations for the country where the unit is being installed at hand.



CAUTION

- *Before the connection work, possible losses of flow, temperature and voltage drops, etc. that might affect the distances between planned connection points and the unit must be taken into account.*
- *As a result, each connection must be sized accordingly.*

1.15 Instructions for installation and connection of the unit

Additional specifications for the gas connection (for ARG/ARD models only)

To correctly size the gas supply pipe, keep in mind the flow required, the specific density of the gas and the length of the stretch.

The fact that the heating value of the gas can vary from town to town should also be kept in mind. The heating value of the gas should be checked with the utility company.

1.15.6 Connection and preparation of the various connections**Gas**

A specific line should be used for gas supply. Its installation must comply with country and local safety regulations.

**NOTE**

For further information on this subject, always keep the current regulations for the country where the unit is being installed at hand.

Access for the gas supply pipe connection

Access for the gas supply pipe connection is through the opening on the front panel of the unit -1-.

A special grommet, kept in fan compartment, is provided for the gas supply pipe. This grommet should be placed in the panel at the front of the unit at the time the gas supply pipe is installed.

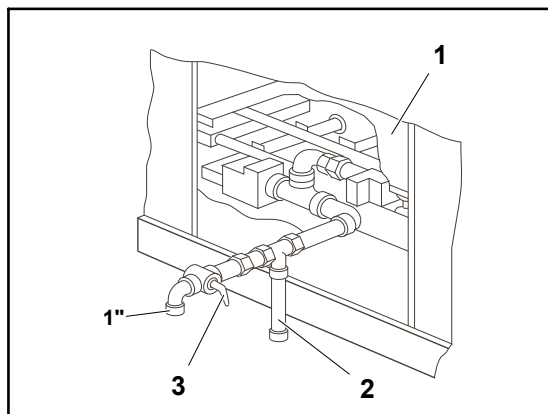
**Important recommendations for the installation of the gas supply pipe**

1. If the supply line needs to carry gas when there is condensation, then a device for its collection and discharge should be installed -2-.
2. Install a manual gas supply shut-off valve -3- if required by the current regulations in the country the unit is being installed in.
3. Install a ground in the gas supply line.
4. Use a wrought iron or steel pipe for the installation of the gas supply line.
5. Before installing the pipe hit the outside with a hammer to get rid of any dirt or scale it might have inside. Use compressed air to expel any residue and particles that might be there.
6. Apply a moderate amount of sealing paste to the threads of the male part of the joint.

**DANGER**

- *Natural gas may contain a small quantity of propane, which is an efficient solvent of lead carbonate and most common commercial compounds.*
- *In installations involving wrought iron or steel, a specialised putty should be used to seal them.*
- *Sealing material that complies with the BS6956 standards, part 5 or equivalent may be used.*

7. Purge the air from the gas supply line of the unit before using it.
8. Open the unit's main gas supply valve.
9. Apply a soapy water solution to all joints to test for any leaks.

**DANGER**

- *DANGER OF EXPLOSION. Never use a flame to verify the absence of leaks in the installation joints.*
- *During gas supply line pressure tests with pressures greater than 0.5 PSI (3.5 kPa), the burner and its manual shut-off valve must be disconnected from the system of gas supply pipes.*

Gas. Modification for service with LPG (Liquefied Petroleum Gas, propane gas)

All units with gas heating are specially manufactured to operate with natural gas. The unit can be modified to operate with LPG (Liquefied Petroleum Gas, propane gas) if necessary. This involves a conversion kit that is assembled during the installation work.

A specific line should be used for gas supply. Its installation must comply with country and local safety regulations.

The LPG propane pressure must be at 37 mbar with the unit at full load for it to operate correctly.

Three main factors must be taken into consideration in order to keep the gas pressure values correct:

1. Speed of gas evaporation, which depends on:
 - a. the temperature of the liquid and
 - b. the size of the "wet surface" of the container or containers.
2. Correct pressure regulation.
3. Pressure drop in the supply lines between the regulators and the unit. The diameter of the pipe depends on its length and the total load of all units.



NOTE

LPG propane gas tank and component manufacturers, as well as their suppliers, can provide complete information about the sizing of the tank in regards to evaporation, pipes, and recommended regulator adjustments.

Important recommendations for the installation of the gas supply pipe: [Gas](#), see on page 30.

Electricity. Power and control

POWER LINE

Power must be supplied to the unit through a specific power supply line with an exclusive power control and differential breaker, installed in line with national and local regulations.



NOTE

For further information on this subject, always keep the current regulations for the country where the unit is being installed at hand.

Make sure that the electricity supply line has enough capacity to power the unit. Its length, the cable diameter and their protection (cover or jacket) should be appropriate for the unit.

Use a multimeter to check that the supply voltage stays within the accepted limits, [Technical and physical data for ARC \(only cooling\) and ARG \(only cooling + gas heating\)](#), see on page 5, or [ARH technical and physical data \(heat pump\) and ARD \(heat pump + gas heating\)](#), see on page 7.

To install the power cable, loosen the closures -1- by 1/4 turn and remove the electrical board panel.

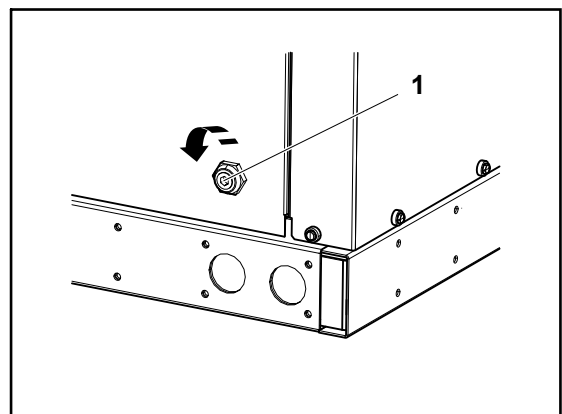

1.15 Instructions for installation and connection of the unit

Bringing the power and control cables directly from the Roof-curb

Remove the protective plate -1-.

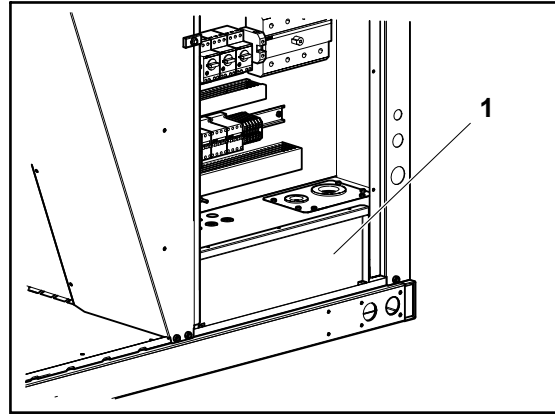

Pull the cables through the gland at the base of the unit -1- and -5-.

Pull the cables towards the electrical panel through the grommets -2- and -4-.

Seal the glands with silicone to ensure they are leak-proof.

Replace the protective plate.

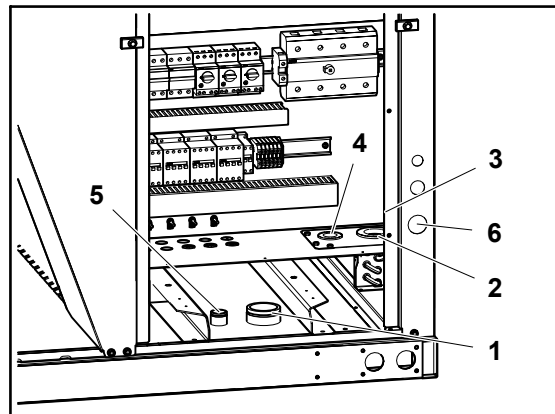
**Passing the power and control cables through the front of the unit.**

Exchange the position of the side cover -3- and the plate that has the grommets -2- and -4-.

Press the appropriate openings on the edge of the unit -6- until they are released.

Place gland that fits the cable and pull the cable towards the electrical panel through the grommet -2-.

Connect the cable to the input connections indicated and firmly tighten the securing bolts. Also consult the Wiring Diagrams.

**NOTE**

The complete wiring diagram for the unit is attached to the inside of the electrical panel.

The electrical panel is fitted with a phase detector to ensure the electrical connection follows the sequence of phases R-S-T. Where the connection does not respect this sequence, the electronic control circuit remains disconnected and the unit will not start.

To correct the phase sequence, change the position of two of the three unit power cables on the input terminals.

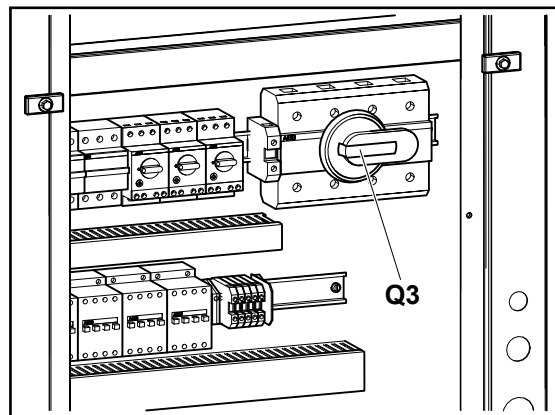

CONTROL LINE

Bringing the power and control cables directly from the Roof-curb

Remove the protective plate -1-.

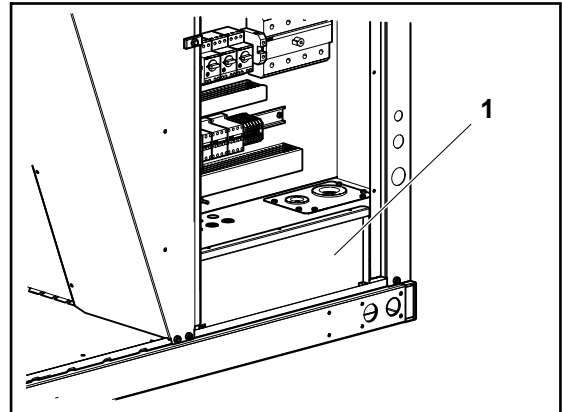

Pull the cables through the gland at the base of the unit -1- and -5-.

Pull the cables towards the electrical panel through the grommets -2- and -4-.

Seal the glands with silicone to ensure they are leak-proof.

Replace the protective plate.

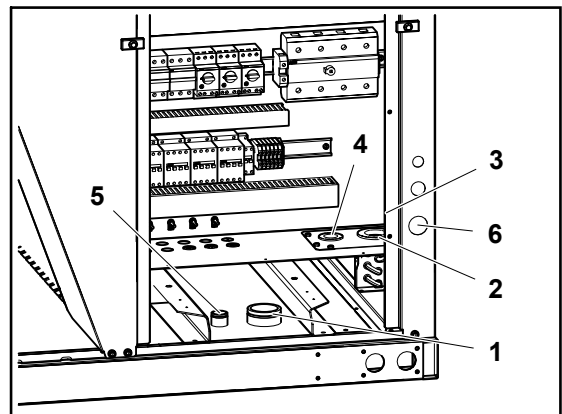

Passing the power and control cables through the front of the unit.

Exchange the position of the side cover -3- and the plate that has the grommets -2- and -4-.

Press the appropriate openings on the edge of the unit -6- until they are released.

Place gland that fits the cable and pull the cable towards the electrical panel through the grommet -2-.

Connect the cable to the terminals indicated and firmly tighten the securing bolts. Also consult the Wiring Diagrams.



NOTE

The complete wiring diagram for the unit is attached to the inside of the electrical panel.

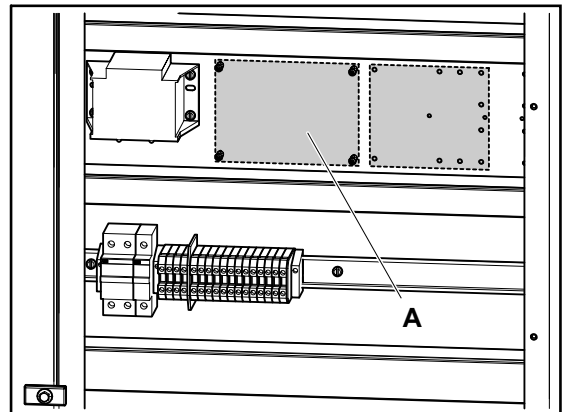

Condensates. Insulation and/or protection of ducts

Condensates should be released by means of a specific installation in line with local or national regulations.

**NOTE**

For further information on this subject, always keep the current regulations for the country where the unit is being installed at hand.

Condensate drain pipes are connected using a female thread 1" BSP through an opening -1- situated on the base of the unit.

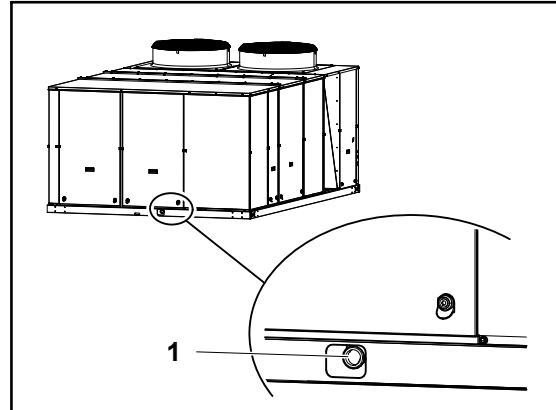

Install a drain trap on the exhaust outlet of the unit. The drain trap must have an access register -1- to facilitate emptying and cleaning when necessary.

Apply a moderate amount of sealing paste to the threads of the male part of the joint.

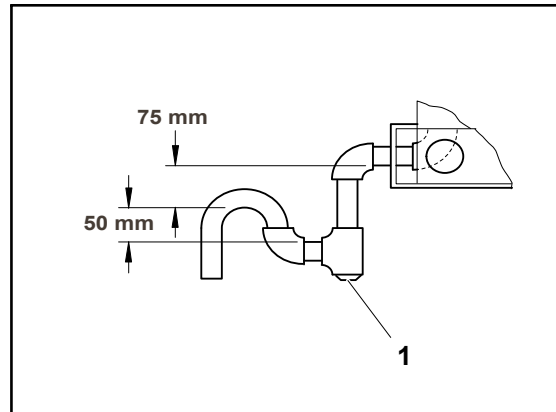

Lay the condensate drain pipe from the female connection on the bottom of the unit to a nearby drain.

**NOTE**

The condensate drain pipe should be at a minimum gradient of 2% (2 cm of drop for each metre in length).

Protection against ice

In areas where the temperature can be 0°C or less, there should be some kind of additional protection to prevent the water contained in the condensate drain pipe from freezing.

An heating element (wire heater) should be installed in the drain trap and in the condensate drain pipe.

For units with heat pumps, heating elements must also be installed in the outdoor coil tray to prevent possible ice accumulation.

1.16 Instructions for starting up the unit

1.16.1 Electrical checks

DANGER

- *All side panels except for that of the electrical box, must be fitted, closed and secured with their corresponding locks before turning the general switch on the unit.*
- *The unit has a remote control, which means that the fan turbine may start unexpectedly.*

CAUTION

Loose connection terminals produce overheating of cables and terminals. The unit will work incorrectly and there is a risk of fire.

Check that the cables are firmly secured to their connection terminals.

CAUTION

Do not turn on the general switch on the unit or start the unit until all installation work has been completed.

Initial connection of the unit

The general switch on the unit -Q3- must be turned on once all of the planned accessories are installed and before starting the unit.

Press the "Test" button for two seconds so that the unit recognises the installed accessories. When the recognition process is complete, the red pilot light switches off.

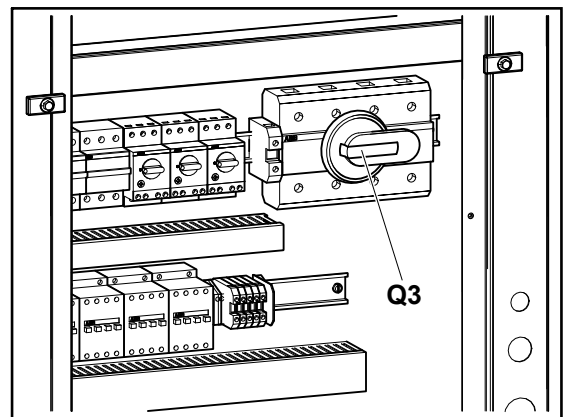

Rotating direction of the Scroll compressors

The scroll compressors and the fans only operate correctly if they rotate in the correct direction. All of the motors and compressors in the unit are connected so that they rotate correctly.

If the compressors are not connected correctly and are rotating in the wrong direction:

- The compressor will not compress.
- Operating noise will be abnormal.
- Electricity consumption (A) will be low.
- They overheat.

1.16.2 Starting the gas heating, ARG/ARD

DANGER

- *In order to prevent damage to the gas valves, the burner group should be disconnected from the gas pipe system during the pressure test.*
- *Only an Authorised Technical Assistance Service for Johnson Controls Inc. with the appropriate technical resources and adequately trained personnel may perform the start-up tasks for gas heating on the unit.*

Prior checks

1. Check that the type of gas to be used is the same as that specified on the ticket situated to the left of the gas section access panel.

1.16 Instructions for starting up the unit

2. Check that the covers for the gas outlets and the combustion air intake have been correctly installed. See *General dimensions and accesses (models 045/060)*, see on page 14, or *General dimensions and accesses (models 075/090)*, see on page 16.
3. Check that the combustion air inlet is free of obstruction from dirt, snow, branches, dry leaves, residue or other objects.
4. Make sure the gas supply line complies with safety regulations, that it is able to supply an adequate flow and pressure of gas, and that it has been purged of air. See *Gas*, see on page 30, or *Gas. Modification for service with LPG (Liquefied Petroleum Gas, propane gas)*, see on page 31.

On

The burner is equipped with an automatic lighting system.

**DANGER**

Do not try to start the burner manually.

Start-up without the portable YKTOOL test device (accessory)

1. Connect the electrical supply to the unit.
2. Open the unit's gas supply valve.
3. Place the ambient thermostat in the maximum heat.
4. The burner group should light (it might take a few minutes depending on the mode established in the thermostat)

Post start-up checks

Once the entire control circuit is activated and the heating section is operating, the following checks should be made:

1. Make sure there are no gas leaks either in the unit's pipes or in the supply pipes.

**DANGER**

Never use a flame to verify the absence of leaks in the installation joints. DANGER OF EXPLOSION.

2. Check that the pressure of the supply gas is within the limits designated on the rating plate.
3. The supply pressure at full output should be checked for all gas appliances in the building.
4. Pressure in the gas supply line should never exceed 25 mbar. In units powered by natural gas, the operating pressure should never fall below 12.5 mbar.

**NOTE**

If the gas supply is outside these limits, contact the gas utility company or your local representative for corrective measures.

5. Check that gas pressure in the manifold is correct. See *Adjust gas valves / thermal breaker*, see on page 37.

6. Check that the flame in the burners is completely blue.

- A. Burner
- B. Heat exchanger tube
- C. Burner flame
- D. Pilot tube
- E. Supply manifold

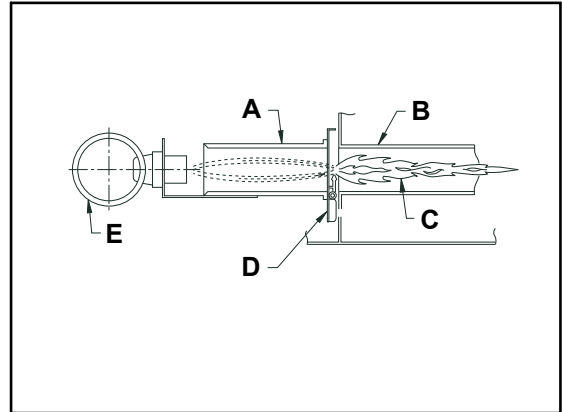

7. After 15 minutes of operation, and using a gas combustion analyser, check the CO, CO₂ and Nox content if possible, in the smoke duct outlet. With both stages of heat operating, the carbon monoxide (CO) content should be less than 0.1 % (1000 ppm). The CO/CO₂ ratio should be less than 0.02.

Adjust gas valves / thermal breaker

ARD/ARG Models:		045, 060, 075, 090	
Burner model	N320		
Heating capacity (kW)	Total (LHV)	Standard	85
		Optional high power	100
	Net	Standard	76
		Optional high power	90
Gas family	2ND-H/E (G20)	2ND-L (G25)	
Gas valve adjustment (mbar)	Main regulator	10,5	15,2
	Second stage regulator	–	–
	Stage regulator	9,9	14,6
Thermal breaker limits (°C)	Automatic reset	82	
	Manual reset	93	

LHV: Lower heating value.

- A. Main regulator adjustment
- B. Connection flange
- C. Spigot for reading inlet pressure

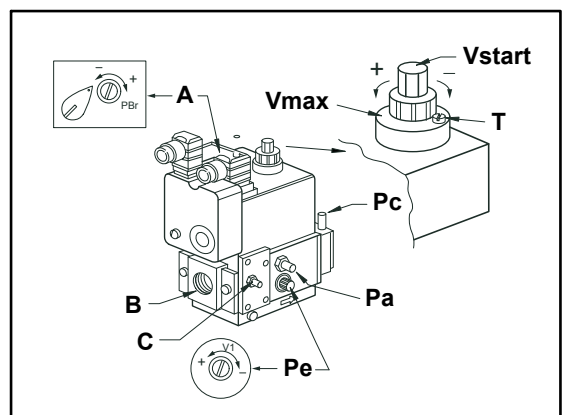

Gas pressure regulation in the burner supply manifold

The units are manufactured and regulated for the 2ND-H (G-20) natural gas family.

Gas is regulated depending on the type of gas used, follow the steps below and adjust the two valves according the values specified in [Adjust gas valves / thermal breaker](#), see on page 37.



CAUTION

The gas valve in units converted to LPG (Liquid Petroleum Gas, propane) should be regulated according to the technical instructions included in the conversion kit.

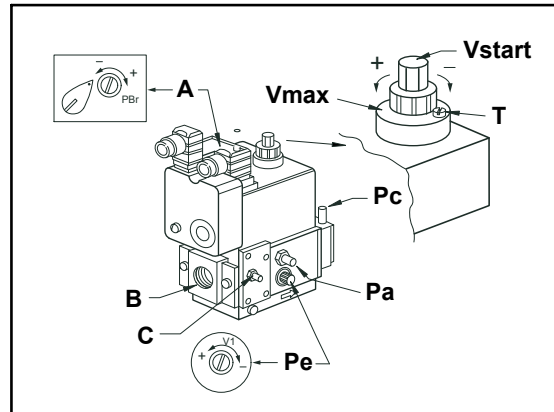

1. Tasks to do first:

- Regulation of the inside pilot **-Pe-**. The regulator screw is under the plastic cap. Starting at the “completely closed (-)” position, make five complete anti-clockwise turns **-V1-** using a flat tipped screw driver.
- Quick partial opening regulation **-Vstart-**. The regulator screw is under the plastic cap. Starting at the “completely closed (-)” position, make a complete anti-clockwise turn **-Vstart-** using the cap itself.



CAUTION

- *Do not use a screwdriver to make a quick partial opening regulation **-Vstart-**.*
- *Never move the screw resealed in red.*

2. Regulating the GV1 valve with a heat stage operating.

- Adjust the main regulator (reading pressure Pa).
- Adjust the gas stage regulation fly wheel **-Vmax-**. To do so, loosen the first cylindrical head screw **-T-** next to the symbol **-**.
- Check the pressure reading in the manifold valve outlet **-Pc-**.
- Once adjusted, tighten the screw **-T-**.

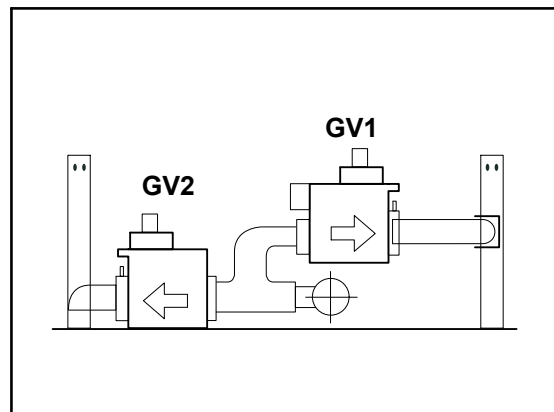

CAUTION

Never move the resealed blue screw next to the (+) symbol.

3. Regulating the GV2 valve with two heat stages operating.

- Adjust the main regulator and the gas stage following the same procedures as described for valve GV1.
- After fifteen minutes of operation with the 2 heat stages, check the content of CO and CO₂, according to [Post start-up checks](#), see on page 36.

Temperature rise regulation

The temperature rise (or difference in temperature between the return air and the hot supply air) should be within the specified limits. [Capacities and application data for gas ARG/ARD](#), see on page 10.

Once the temperature rise has been determined, the flow may be calculated as follows:

$$m^3/s = \frac{0.9 \times \text{kW gas input (*)}}{1.2072 \times \text{°C Temperature rise}}$$

(*) Based on 90% rated output and on the net heating value of the gas.

Find the temperature rise after 15 minutes operating. So as not to be affected by radiant heat from the exchanger, the reading for hot air should be taken in the supply duct at a minimum of 2 metres from the unit connection.

Increase the air flow of the fan to **reduce** the temperature rise; **reduce** the air flow of the fan to **increase** the temperature rise.

1.17 Unblocking the unit safely in case of breakdown

DANGER

- *All side panels except for that of the electrical box, must be fitted, closed and secured with their corresponding locks before turning the general switch on the unit.*
- *The unit has a remote control, which means that the fan turbine may start unexpectedly.*

To unlock the unit, see "Restarting the HVAC unit in case of fault" in the User Manual.

If the thermostat display keeps showing the pilot light -1- and any fault code or if the HVAC unit does not start, contact a Johnson Controls Inc. Authorised Technical Assistance Service.

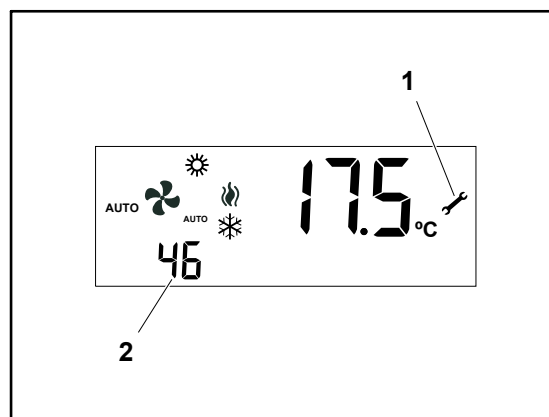

1.18 Regular maintenance tasks performed by specialised personnel

Like any other machine, the unit requires regular maintenance, as the wear to which some of its parts are subjected can affect its mechanical reliability, electrical consumption and working life.

In order to keep the unit in similar working order to when it was installed and commissioned, a series of maintenance tasks must be performed every so often.

Furthermore, all maintenance and servicing tasks required by local and national regulations must be carried out.

DANGER

Only a Johnson Controls Inc. Authorised Technical Assistance Service with the appropriate technical resources and suitably trained personnel may perform the unit maintenance tasks.

CAUTION

Johnson Controls Inc. shall not be considered responsible for any damage caused by inappropriate use or maintenance of the unit that is in any way inconsistent with that described in this document or others specifically provided with the platform.

1.18 Regular maintenance tasks performed by specialised personnel

1.18.1 Planned Maintenance Schedule

The following table shows the recommended frequency for regular maintenance tasks. Depending on the environmental and working conditions where the unit is installed, maintenance tasks may be carried out more or less frequently. The units must undergo all planned maintenance, without exception.

The person responsible for the building or property where the unit is installed must ensure that these inspections are performed at the appropriate time. Likewise, this person should keep and maintain a log book reflecting both planned and unplanned work by the Johnson Controls Inc. Authorised Technical Assistance Service.

Task	Frequency			
	1 month	2 months	6 months	Annual
Belts (indoor fan)		X		
Air filters	X			
Indoor coil (evaporator)		X		
Condensate tray and drain trap		X		
Outdoor coil (condenser)		X		
Outdoor air intake (accessory)	X			
Coolant circuit			X	
Electrical and mechanical operation			X	
Integrity of the unit structure and components				X
Hot water coil (accessory)				X
Gas heating (ARG/ARD Models)				X

1.18.2 Maintenance tasks performed by specialised personnel



DANGER

- *The unit has a remote control, which means that the fan turbine may start unexpectedly.*
- *Disconnect the general switch on the unit before removing any of its side panels.*

Belts (indoor fan)

Check their condition and correct tensioning.

If it is necessary to replace the belts, they should be the same type and size as the originals.

Tensioning of the belts and adjusting the pulley

All units incorporate single speed motors with belt transmission for indoor ventilation.

1. Loosen the nuts **-A-**. Never loosen the nuts **-C-**.
2. Tighten the belts by turning the screw **-B-** until the belt moves: 20...23 mm.
3. Tighten the nuts **-A-**.
4. Check the tension of the belts twice during the first 24 hours of unit operations.



NOTE

The fan motor variable diameter pulley can be regulated in order to obtain the supply air flow desired.

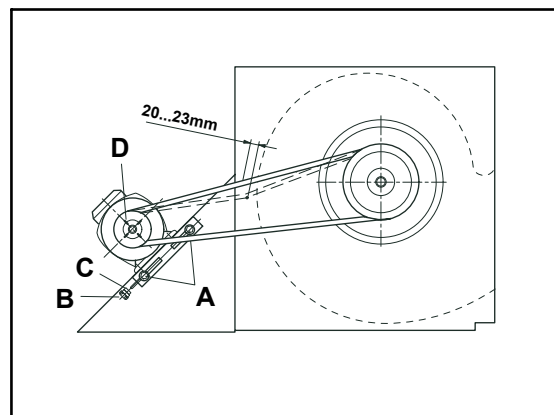

Pulley adjustment (models 045/060/075: 1 groove; models 090: 2 grooves)

Loosen the nuts **-A-**. Never loosen the nuts **-C-**.

Loosen the belts by turning the screw **-B-**.

Loosen the set bolts **-D-** to release the mobile rim **-E-**.

To increase or decrease the opening of the pulley, turn the mobile rim **-E-** on the thread of the fixed core of the pulley in the appropriate direction.

Apply sealant to the threads of the set bolts **-D-** and fully tighten, checking that they match up to their housing in the fixed core of the pulley.

1. Pulley completely closed (maximum diameter). Maximum air flow.
2. Pulley completely open (minimum diameter). Minimum air flow.

DP Pulley diameter

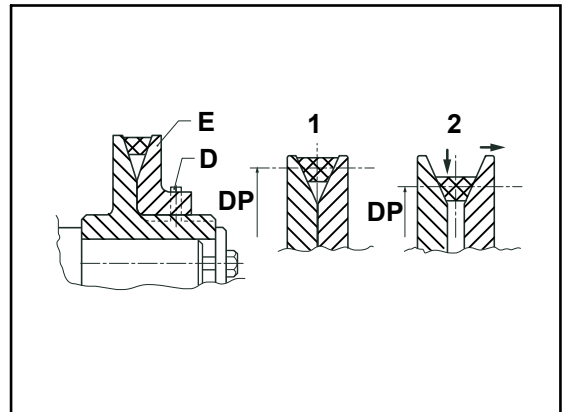

CAUTION

In the case of model 090, both of the pulley grooves should be at the same distance from the fixed core of the pulley (same number of open or close turns).

1. Pulley completely closed (maximum diameter). Maximum air flow.
2. Pulley completely open (minimum diameter). Minimum air flow.

DP Pulley diameter

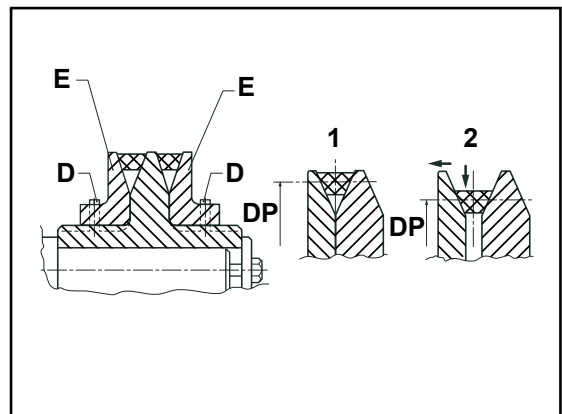

Air filters

The air filters should be replaced by new ones of the same type and size, as required.

Slide the unit filters out on their guides to replace them.



INFORMATION

If the unit has an energy recovery system (accessory), it is important to follow the planned maintenance frequency for air filters.

Indoor coil

Visually inspect the indoor coil when performing air filter maintenance.

The complete surface of the fins must be kept clean. If they need to be cleaned, use a soft brush or a vacuum cleaner, taking special care not to damage the fins.



DANGER

Never use a water hose to clean the indoor coil compartment.

Condensate tray and drain trap

Remove all dirt and residue accumulated in the condensate tray.

Check that neither the condensation outlet nor the drain trap is blocked.

Check that the condensate (water) has been correctly released to the outside.

Fill the drain trap with water if required (prime it).

1.18 Regular maintenance tasks performed by specialised personnel

Outdoor coils

The complete surface of the fins must be kept clean. If they need to be cleaned, use a soft brush or a vacuum cleaner, taking special care not to damage the fins.

Given that they are exposed to the outdoors, the fins can accumulate a lot of dirt and grime (dust, soot, sand, etc.). To clean the fins more thoroughly, use water with a neutral detergent (e.g. washing-up liquid). Clean from the inside out and from top to bottom.

Outdoor air intake (accessory)

If the system has an economiser, motorised damper or energy recuperation system, maintenance work should be performed for the air filters included on the inside of the rain hood.

Check that the aluminium mesh and the filter frames are in good condition.

If necessary, clean the filters more completely using water with a neutral detergent (for example household dish soap).



CAUTION

The filters have an arrow indicating airflow direction stamped on the frame, the arrow should point to the inside of the unit.

Coolant circuit

Before the start of each season when the unit is in use, a thorough check of the coolant circuit must be made, including operating pressures, controls and temperature rises, etc.

Electrical and mechanical operation

Before the start of each season when the unit is in use, check the consumption (in amps) of all motors, the condition of the electrical connections and the correct working order of the safety and protection systems.

The motor bearings for both the indoor and outdoor fans are permanently lubricated and do not need additional lubricant during maintenance.

If the unit has an economiser, motorised damper or barometric relief damper (accessory):

Check that the air dampers and their drive motors work correctly.

If the unit has an axial exhaust fan (accessory):

Check the condition of the fan and the operating control.

Condition of the unit structure and components

Check the correct condition of the unit structure and outdoor components for knocks, dents, scratched paint or rust. Check that bolts are properly secured and the condition of leak-proof seals and panel locks and make sure they close properly.

Hot water coil (accessory)

Before the start of each season of operation of the unit, check the level of water in the system, that air has been purged from the coils, and the operation of control components.

Depending on the climate where the unit is installed, the mix of antifreeze and water must be checked.

1.18.3 Gas heating (ARG/ARD Models)

Gas valve filter



DANGER

Close the unit's gas supply valve before accessing the valve filter.

The gas filter **-B-** of the valve is located under a cover **-A-**, on the side face of the valve.

Check the condition of the gas filter in both valves. Clean and replace it if necessary.

In order to mount the filter, place it in the appropriate position **-D-** and attach the cover, tightening the four securing bolts **-C-** correctly and uniformly in order to ensure they are air tight.

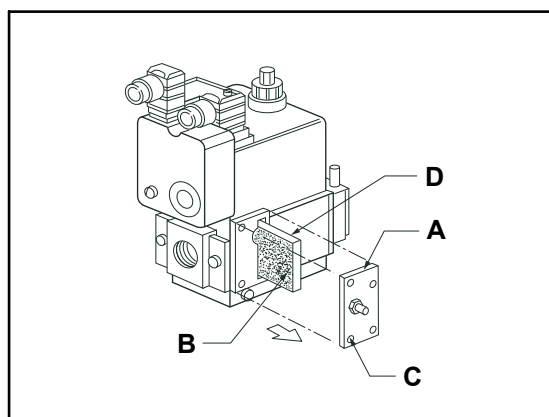

Burners

Check how the flame in the burners looks.

If it does not look right, the burners may need cleaning. To do so, remove the burner group as specified in *Instructions for burner and injector inspection*, see on page 43.

Gas injectors

Visually check that the injector calibrated holes are not partially obstructed. Clean them if necessary as described in *Instructions for burner and injector inspection*, see on page 43.

Combustion air inlet

Check that the combustion air inlet is free of obstruction from dirt, snow, branches, dry leaves, residue or other objects.

Discharge of combustion gases

Check that the combustion gasses discharge is free of obstruction from dirt, snow, branches, dry leaves, residue or other objects.

Check that there is no accumulation of soot on the panels around the exhaust tubes. If there is soot accumulated, it could be that combustion is incomplete. If that is the case, make the checks indicated in *Post start-up checks*, see on page 36.

Instructions for burner and injector inspection



DANGER

Close the gas supply valve and shut off the electrical power to the unit before inspecting the burners and injectors.

1. Disconnect the gas supply pipe from the unit.
2. Remove the upper and lower panels **-A-** and **-B-**, to access the gas selection.
3. Disconnect the gas valves, the ignition electrodes, the flame sensors, and the temperature sensors.

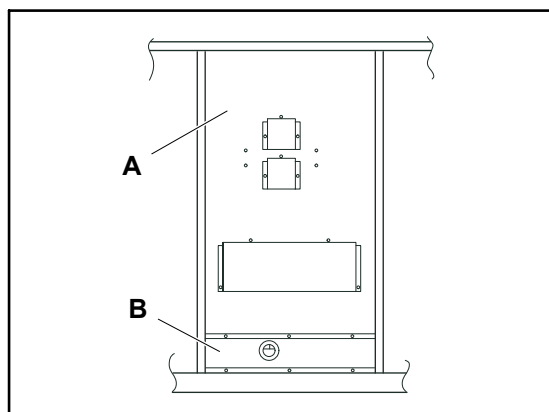

1.18 Regular maintenance tasks performed by specialised personnel

4. Loosen and remove the 4 bolts -T- that fasten the burner group to its support.

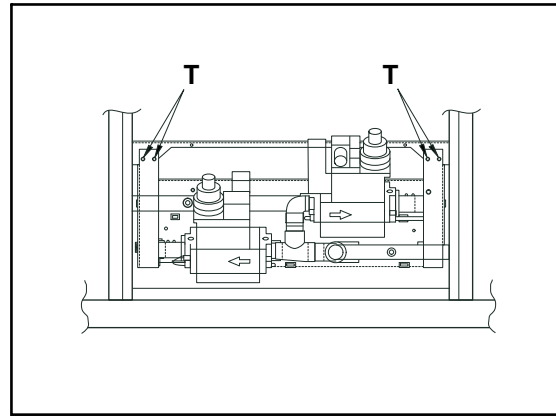

5. Remove the burner group, pulling it up and out. The burners and injectors can now be accessed for inspection and cleaning.

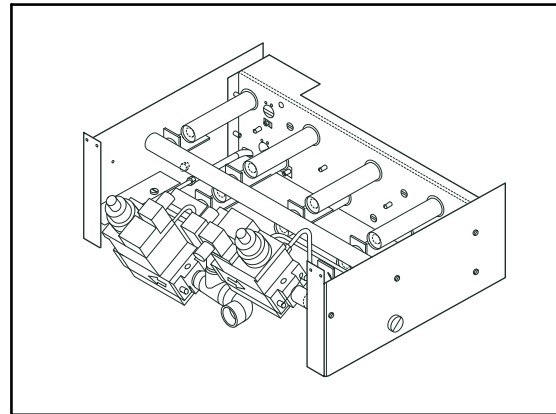

6. Before returning the burner group to its place, check that the separation between the ignition electrode and the far burner is between 2 and 3 mm.

- A. Gas flow
- B. Burners
- C. Connector
- D. Teflon support
- E. Electrode

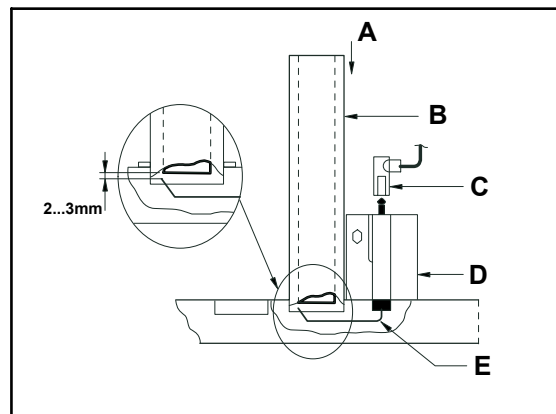

Cleaning the flue passages and heat exchanger

As long as combustion regulation is adequate, it is rare that the heat exchanger needs to be cleaned. If the heat exchanger becomes sooty, it may be cleaned in the following manner:

1. Remove the burner group according to [Instructions for burner and injector inspection](#), see on page 43.
2. Remove the bolts from the upper part of the casing and from the top turbine of the combustion gas draft blower.
3. Remove the bolts that hold the upper part of the flue box without tearing the insulation beside it. Afterwards, remove the central plate dividing the upper and lower flue boxes.

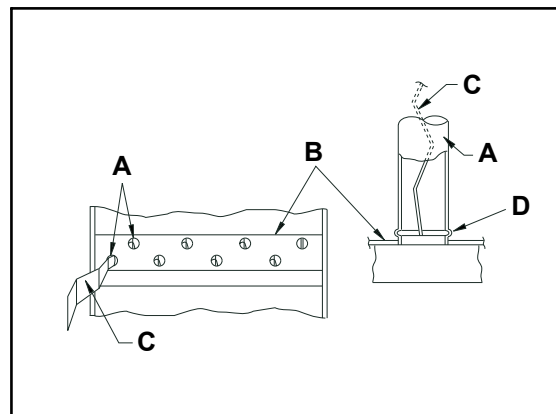

4. Inside the flue box, remove the flue baffles **-C-** from inside the heat exchanger pipes **-B-**. Ensure that the last curve in the baffle fits tightly in the pipe **-A-**, requiring the end of the baffle to be well secured to the pipe collar **-D-**. To take it out, move the end of the baffle towards the centre of the tube, freeing it from the tube collar and then pulling out in a straight line.
5. Using a metal brush with a flexible rod, brush the interior of each of the tubes, brushing to the outside and getting to the very end in the flue box as well as at the beginning at the burners.
6. Also brush all of the inside of the flue box and the baffles.
7. Run the brush over the exhaust hoods, from the side of the flue box downward.
8. If there is a large accumulation of soot, take the draft blower out and clean the turbine and casing.
9. Once the brushing is finished, carefully clean the residue using compressed air. If necessary use a vacuum cleaner.
10. Put the parts back in the reverse order from which they were removed.
11. When remounting the central and upper parts of the flue box, be careful not to tear the insulation beside it.
12. Make sure that all of the joints on the side with the combustion system ventilation are air tight. Apply high temperature (260 °C) sealing putty to do it.

1.19 Unit sound pressure data

Octave band sound spectrum dB(A), outdoor

Models	045	060	075	090
125 Hz	82,4	79,4	80,3	80,7
250 Hz	82,1	77,8	78,7	79,1
500 Hz	79	77,3	78,2	78,6
1000 Hz	76	78,2	79,1	79,5
2000 Hz	72,7	73,8	74,7	75,1
4000 Hz	66,2	66,6	67,5	67,9
8000 Hz	60,1	63,1	64	64,4
Sound power level dB (A)	80,8	86,6	87,5	87,9
Sound pressure level at 5 m dB (A)	56,1	61,9	62,8	63,2
Sound pressure level at 10 m dB (A)	50	55,8	56,7	57,1

Octave band sound spectrum dB(A), indoor

Models	045	060	075	090
125 Hz	73,7	75,1	76,7	78,2
250 Hz	71,6	73	74,6	76,1
500 Hz	67	68,4	70	71,5
1000 Hz	61,8	63,2	64,8	66,3
2000 Hz	58,8	60,2	61,8	63,3
4000 Hz	48,9	50,3	51,9	53,4
8000 Hz	47,5	48,9	50,5	52
Sound power level dB (A)	73,2	74,6	76,2	77,7

2

Unit installation data

Please complete the following data to register the full details of the installation and the start-up inspection.
Complete the blank fields or mark the appropriate box, as applicable.

2.1 List of tests for unit start-up

Please complete the following forms to register the full details of the installation and the start-up inspection.

Complete the blank fields or mark the appropriate box, as applicable.

Company performing installation:	
Installing technician:	
Name / project number:	
Location of the unit:	
Address of the unit location:	
Person in charge of the building or property where the unit is installed:	
Installation work start date:	
Unit model number:	
Unit serial number:	
Plate and version:	
Thermostat, model and version:	

General inspection of the unit	
	Visual appearance
	Levelling of the unit
	Check the unit for transport, loading and unloading damage
	Unit installed with sufficient clearance
	Check the circuit for the presence of oil (large coolant leaks).
	Terminals and connections correctly secured in the control panel and accessories
	Air filters installed
	Condensate drain pipe and drain trap installed correctly
	Thermostat and connection cabling installed correctly
	Air duct installation complete and correct
	Accessories and planned options installed (if applicable)

Inspection of the air supply fan	
	Drive belt and pulleys aligned and correctly fastened
	Drive belt tension correctly adjusted
	Verification of direction of rotation

2.2 Start-up data

Inspection of the gas heating section (models ARG/ARD)	
	Verification of the kind of gas supplied to the unit
	Combustion air input hood installed
	Exhaust hoods installed

Inspection of compressors	
	Verification that direction of rotation is correct

2.2 Start-up data

Electrical data

	Rating plate	Actual
Power supply	Check specifications in the Installation Manual	
Control voltage		
Fan consumption (A)		
Consumption of condenser fan 1 (A)		
Consumption of condenser fan 2 (A)		
Consumption of compressor 1 (A)		
Consumption of compressor 2 (A)		
Consumption of supply fan (A)		
Heating element 1 (Optional)		
Heating element 2 (Optional)		

Cool and heat modes

Coolant circuit. Compressor 1		
Mode	Value	
Subcooling (min. 8 K, max. 18 K)	°C	Liquid pressure: ____ bar
		Liquid temperature: ____ °C
Superheat (min. 4 K, max. 10 K)	°C	Suction pressure: ____ bar
		Suction temperature: ____ °C
	Complete liquid line checked in sight glass	
	Correct oil level checked in sight glass	

Coolant circuit. Compressor 2		
Mode	Value	
Subcooling (min. 8 K, max. 18 K)	°C	Liquid pressure: ____ bar
		Liquid temperature: ____ °C
Superheat (min. 4 K, max. 10 K)	°C	Suction pressure: ____ bar
		Suction temperature: ____ °C
	Complete liquid line checked in sight glass	
	Correct oil level checked in sight glass	

Air flow rate values

	m ³ /h
Design	
Measured	

Air temperature

Mode (cool or heat):	Temperature (°C)
Outdoor air:	
Supply air:	
Return air:	
Indoor air mix (if economiser is fitted):	

OPTIONS
Heating mode (hot water coil)

Air temperature	
Capacity: _____ (kW)	Temperature (°C)
Supply air (at 100 %)	
Return air	

Hydraulic circuit		
	Temperature (°C)	Pressure (bar)
Water inlet		
Water outlet		

Heating mode (gas burner) (ARG/ARD models)

Air temperature	
Capacity: _____ (kW)	Temperature (°C)
Supply air (at 100 %)	
Return air	

Gas circuit (Natural gas)			
Gas family		G20	Pressure (mbar)
		G25	
Supply line		Min 12.5 / Max 25 mbar	
Gas valve adjustments	Main regulator (PBr)		
	Stage regulator (V _{max})		
Gas consumption m ₃ /h			

2.2 Start-up data

Propane gas conversion, G31, if applicable		
Supply line	37 mbar	Pressure mbar

Gas valve adjustments	Main regulator	
	Stage regulator	
	Gas consumption m ₃ /h	

Combustion analyser	
Outdoor ambient temperature	___ °C
Smoke temperature	___ °C
Carbon monoxide CO content	___ ppm or ___ %
Carbon dioxide content CO ₂	___ %
Nitrogen oxide content NO	___ ppm

Others

Outdoor fan 1	Type or model
	Surge protection adjusted

Outdoor fan 2	Type or model
	Surge protection adjusted

Indoor fan	Type or model
	Surge protection adjusted

Belts	Type or model
Economiser	Minimum outdoor air setting

3

Cooling diagrams

3.1 ARC/ARG 045/060 Cooling diagrams

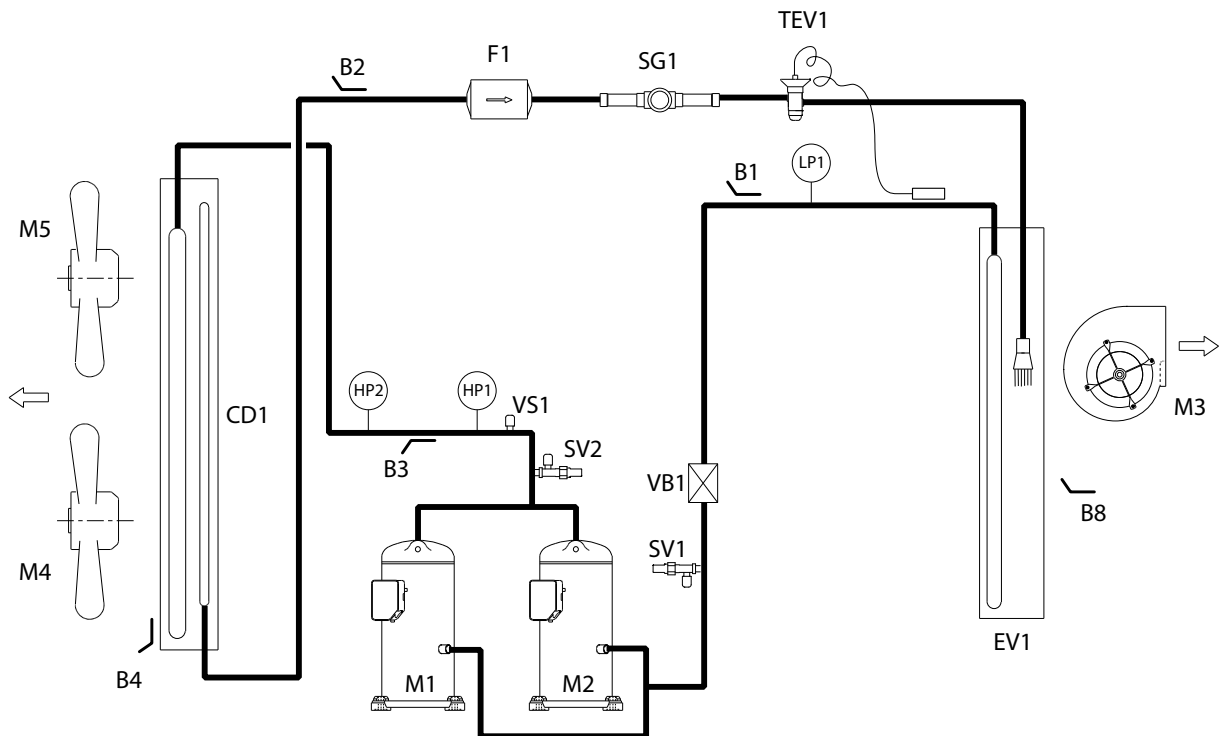

B1	Suction temperature sensor	LP1	Low-pressure switch
B2	Liquid temperature sensor	M1/2	Compressor
B3	Discharge temperature sensor	M3	Supply fan (centrifugal)
B4	Outdoor air temperature sensor	M4/5	Outdoor fan (045: M4 and 060/090:M4/M5)
B8	Supply air temperature sensor	SV1/2	Service valve
CD1	Outdoor coil	TEV1	Expansion valve
EV1	Indoor coil	VB1	Ball valve
F1	Dehydrator filter	VS1	Schrader connection
HP1	High-pressure switch	SG1	Liquid sight glass
HP2	Low ambient switch		

3.2 ARC/ARG 075 Cooling diagrams

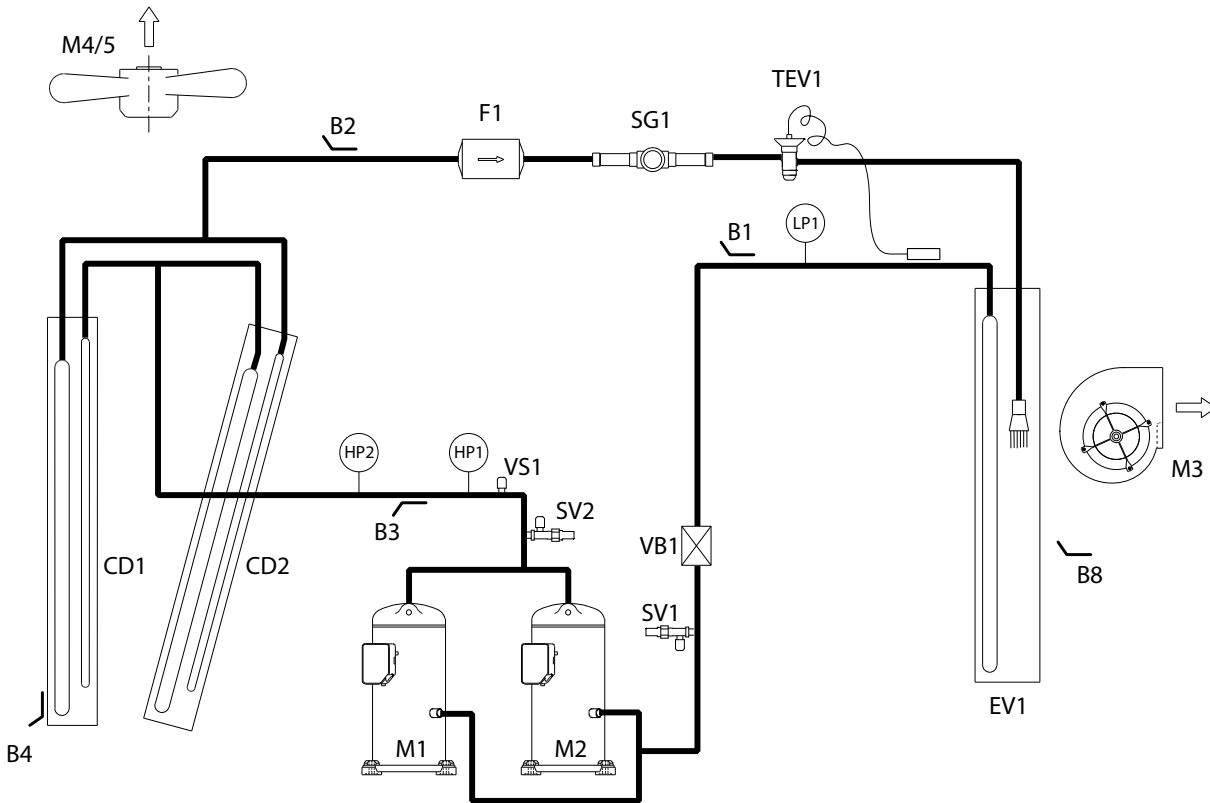

B1	Suction temperature sensor	LP1	Low-pressure switch
B2	Liquid temperature sensor	M1/2	Compressor
B3	Discharge temperature sensor	M3	Supply fan (centrifugal)
B4	Outdoor air temperature sensor	M4/5	Outdoor fan
B8	Supply air temperature sensor	SV1/2	Service valve
CD1 / 2	Outdoor coil	TEV1	Expansion valve
EV1	Indoor coil	VB1	Ball valve
F1	Dehydrator filter	VS1	Schrader connection
HP1	High-pressure switch	SG1	Liquid sight glass
HP2	Low ambient switch		

3.3 ARC/ARG 090 Cooling diagrams

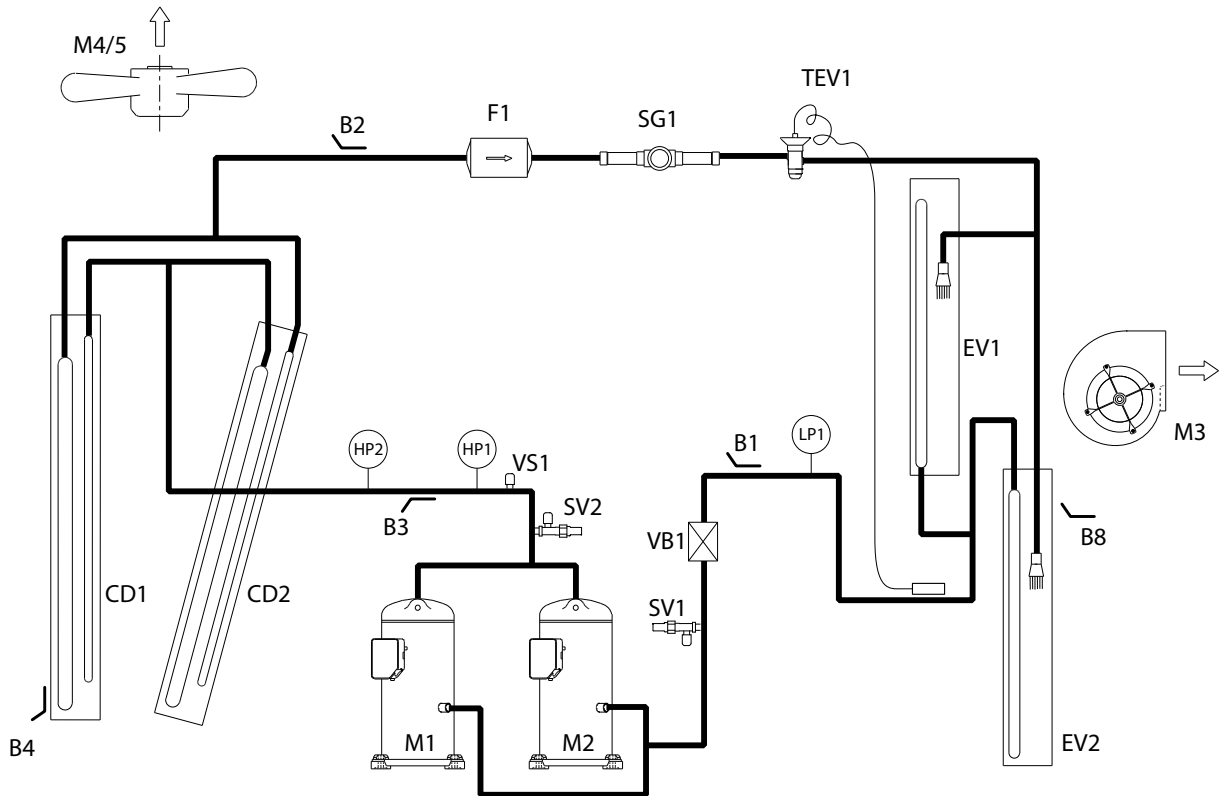

B1	Suction temperature sensor	LP1	Low-pressure switch
B2	Liquid temperature sensor	M1/2	Compressor
B3	Discharge temperature sensor	M3	Supply fan (centrifugal)
B4	Outdoor air temperature sensor	M4/5	Outdoor fan
B8	Supply air temperature sensor	SV1/2	Service valve
CD1 / 2	Outdoor coil	TEV1	Expansion valve
EV1 / 2	Indoor coil	VB1	Ball valve
F1	Dehydrator filter	VS1	Schrader connection
HP1	High-pressure switch	SG1	Liquid sight glass
HP2	Low ambient switch		

3.4 ARH/ARD 045/060 Cooling diagrams

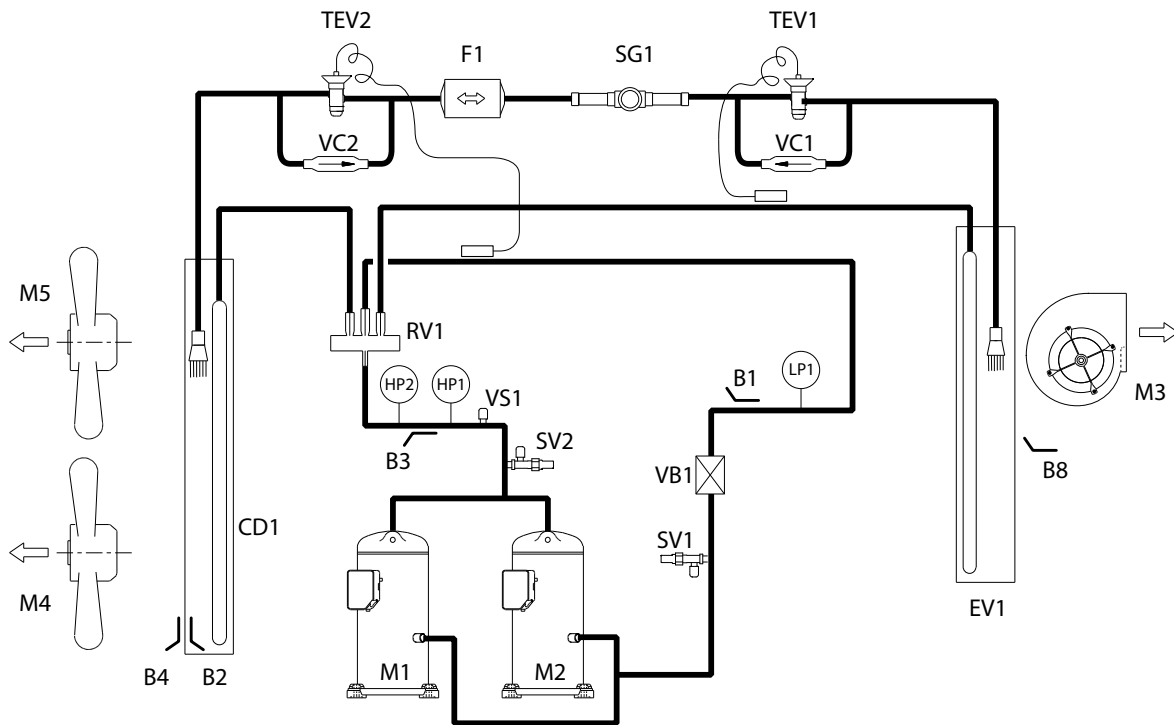

B1	Suction temperature sensor	M1/2	Compressor
B2	Liquid temperature sensor	M3	Supply fan (centrifugal)
B3	Discharge temperature sensor	M4/5	Outdoor fan (045: M4 and 060 : M4 / M5)
B4	Outdoor air temperature sensor	RV1	Four-way valve
B8	Supply air temperature sensor	SV1/2	Service valve
CD1	Outdoor coil	TEV1/2	Expansion valve
EV1	Indoor coil	VB1	Ball valve
F1	Dehydrator filter	VC1/2	Non-return valve
HP1	High-pressure switch	VS1	Schrader connection
HP2	Low ambient switch	SG1	Liquid sight glass
LP1	Low-pressure switch		

3.5 ARH/ARD 075 Cooling diagrams

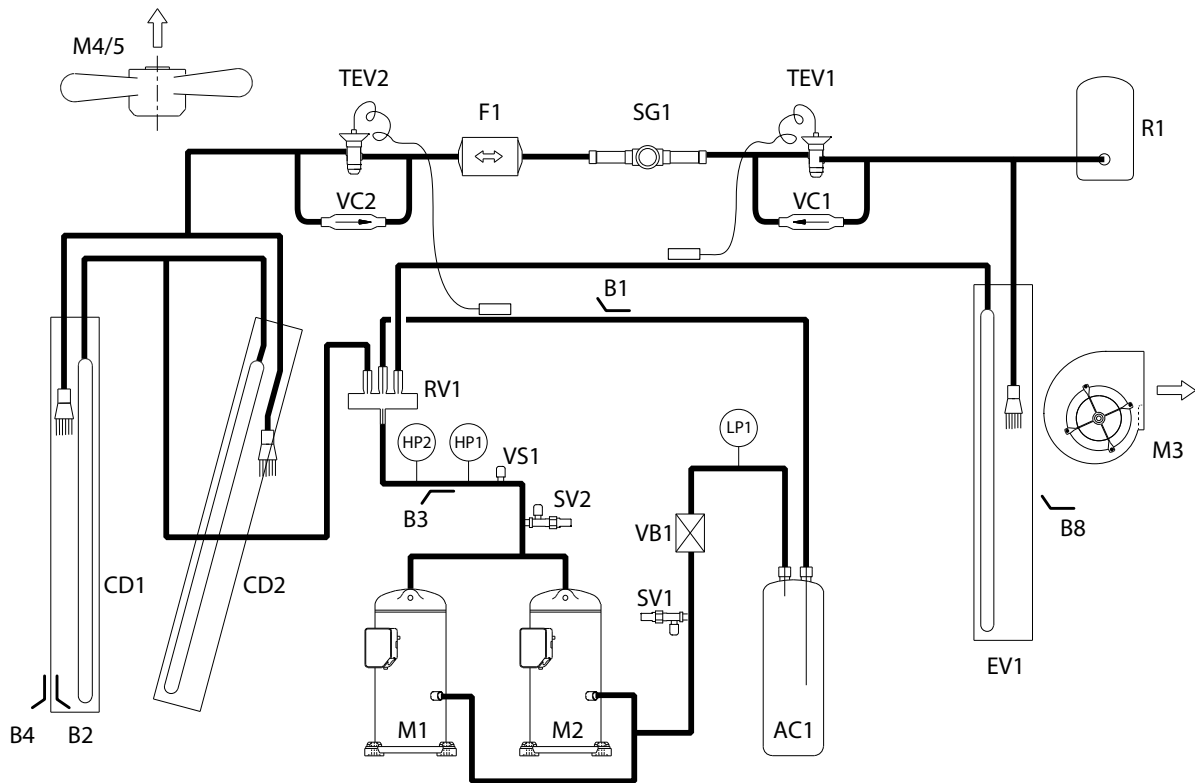

AC1	Suction accumulator	M1/2	Compressor
B1	Suction temperature sensor	M3	Supply fan (centrifugal)
B2	Liquid temperature sensor	M4/5	Outdoor fan
B3	Discharge temperature sensor	RV1	Four-way valve
B4	Outdoor air temperature sensor	R1	Liquid vessel
B8	Supply air temperature sensor	SV1/2	Service valve
CD1 / 2	Outdoor coil	TEV1/2	Expansion valve
EV1	Indoor coil	VB1	Ball valve
F1	Dehydrator filter	VC1/2	Non-return valve
HP1	High-pressure switch	VS1	Schrader connection
HP2	Low ambient switch	SG1	Liquid sight glass
LP1	Low-pressure switch		

3.6 ARH/ARD 090 Cooling diagrams

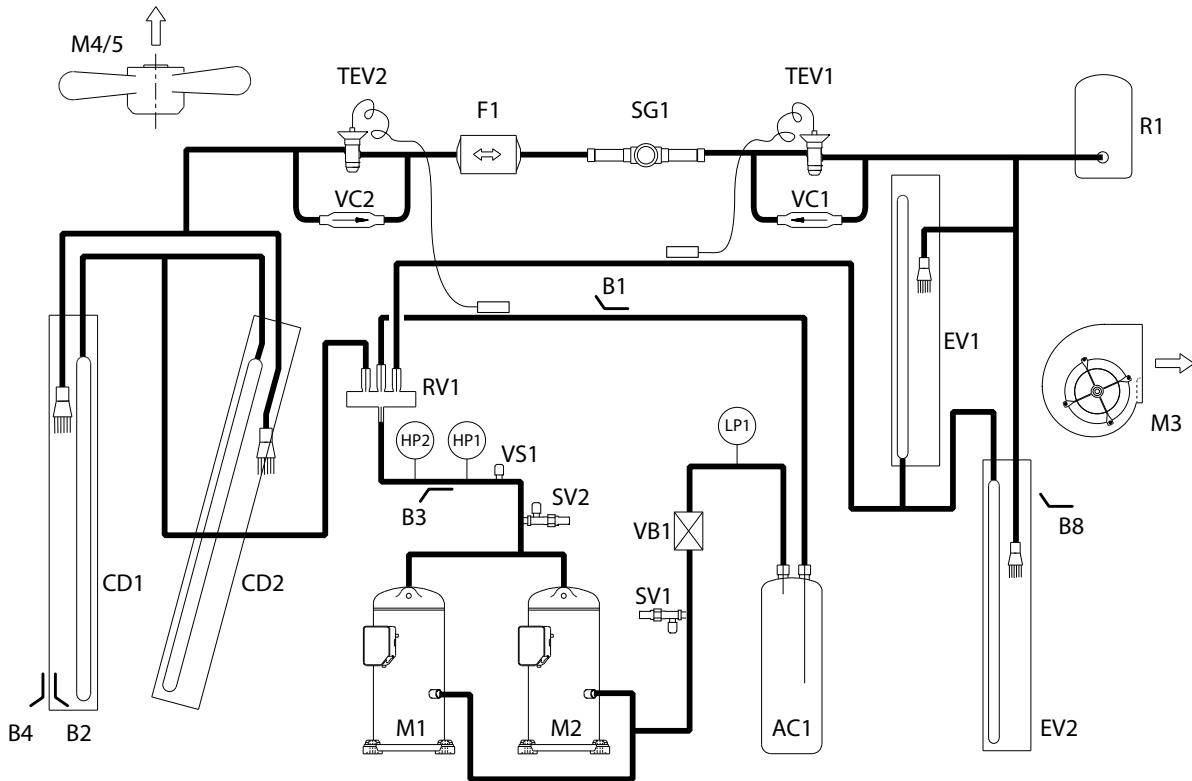

AC1	Suction accumulator	M1/2	Compressor
B1	Suction temperature sensor	M3	Supply fan (centrifugal)
B2	Liquid temperature sensor	M4/5	Outdoor fan
B3	Discharge temperature sensor	RV1	Four-way valve
B4	Outdoor air temperature sensor	R1	Liquid vessel
B8	Supply air temperature sensor	SV1/2	Service valve
CD1 / 2	Outdoor coil	TEV1/2	Expansion valve
EV1 / 2	Indoor coil	VB1	Ball valve
F1	Dehydrator filter	VC1/2	Non-return valve
HP1	High-pressure switch	VS1	Schrader connection
HP2	Low ambient switch	SG1	Liquid sight glass
LP1	Low-pressure switch		

4

Wiring diagrams

4.1 Micro switch configuration

The micro switches are used to establish the following configurations:



ATTENTION

In order to update the new configuration of the micro switches the power supply has to be shut off

MICRO SWITCH CONFIGURATION

Number	Status	Description
1 / 2	OFF/OFF	Defrosting time 0'
	ON/OFF	Defrosting time 30'
	OFF/ON	Defrosting time 60'
	ON/ON	Defrosting time 90'
3	ON	Crossed coils
	OFF	Independent coils
4	ON	Selection of 2 compressors (tandem) - 1 circuit
	OFF	Selection of 1 compressor - 1 circuit
5	ON	Cold selection
	OFF	Heat pump selection
6	ON	4-way valve active in heat
	OFF	4-way valve active in cold
7	ON	Receives signal B from thermostat (active in heat)
	OFF	Receives signal O from thermostat (active in cold)
8	ON	Fan enabled during defrost
	OFF	Fan disabled during defrost

4.2 Fault table

The red LED on the YKNOpen electronic board is responsible for showing the state of faults on the unit:

- When the red LED remains off there are no faults in the unit.
- If the red LED does two series of flashes in a constant sequence, there is a fault which must be checked in the following table:

FAULT TABLE (RED LED)

Red LED flashes		Description
1st Series	2nd Series	
1, 2 or 3	1	Discharge temperature exceeded
	2	High-pressure switch, outdoor fan thermal switch or compressor module thermal switch
	3	Low-pressure switch
	4	Indoor fan thermal switch
	5	Repeated cold start-up or suction temperature < -25 °C
4	1	Gas control 1 or heating element 1 fault
	2	Gas control 2 or heating element 2 fault
	3	Heating element 3 stage fault
	4	Heating element 4 stage fault
	5	Fault in economiser or hot water coil (outdoor supply probe, water return)
	6	Smoke or high temperature detection (accessory) or supply temperature > 80 °C

4.3 Incidents

The green LED on the YKNOpen electronic board is responsible for showing the state of incidents on the unit:

- If the green LED flashes in a constant sequence, there are no incidents in the unit.
- If the green LED does three series of flashes in a constant sequence, there is an incident which must be checked in the following table:



NOTE

The first series indicates the affected circuit: one flash for the first compressor, two for the second, three for the third and four for miscellaneous incidents. A short pause follows. The second and third series specify the direct cause of the incident.

INCIDENT TABLE (GREEN LED)

Green Led flashes			Description			
1st Series	2nd Series	3rd Series	Type	Incident		
1, 2 or 3	1	1	Probes	Discharge probe open or short circuited		
		2		Liquid probe open or short circuited		
		3		Suction probe open or short circuited		
	2	1	Temperature	Repeated defrosting		
		2		The discharge temperature is not recovered		
	4	1	1	Probes	Supply probe open or short circuited	
2			Return probe open or short circuited			
3			Outdoor probe open or short circuited			
4			Water probe open or short circuited			
5			Fault in the enthalpy probes			
2		1	Thermostat	Signal Y1 without signal G		
3		1	Auxiliary heat	Heating element thermal switch 1		
		2		Heating element thermal switch 2		
		3		Heating element thermal switch 3		
		4		Heating element thermal switch 4		
4		4	1	Temperature	The water coil temperature is not recovered	
			2		Outdoor temperature too low	
			3		Water coil performing antifreeze operation	
			4		Supply temperature above 55 °C	
			5		Supply temperature < 25 °C with gas	
5		5	1	Others	Defrost cycle	
					2	There is at least one accessory not found
					3	Air quality demand
					4	Dirty filters
					5	Presence sensor is unoccupied
					6	Suction temperature < 0 °C, economiser
6		6	1	Recovery system	Energy recovery wheel motor trip switch	
					2	Energy recovery fan motor trip switch

4.3.1 Test button

- If the test button is pressed until the green led is activated, certain times are shortened.
- If the test button is pressed until the orange led is activated, any fault that has been detected is reset.
- If the test button is pressed until the red led is activated, the optional accessories and probes connected to the board are identified.

4.4 DPC-1 thermostat

When a fault occurs and there is communication between the unit and the thermostat, the thermostat alternately displays the time and the fault produced according to the unit fault table.

It also displays other faults related to the thermostat.

MICRO SWITCH CONFIGURATION

Type	Thermostat numbers		Description
Thermostat	9	1	Ambient probe open or short circuited
	9	2	Internal probe not calibrated
	9	3	Communication error
	9	4	Fault with AL terminal connected
	9	5	S5 digital probe not detected
	9	6	S6 digital probe not detected
	9	7	S7 digital probe not detected
	9	8	S8 digital probe not detected
	9	9	Digital outdoor probe not detected

4.5 Unit wiring diagrams

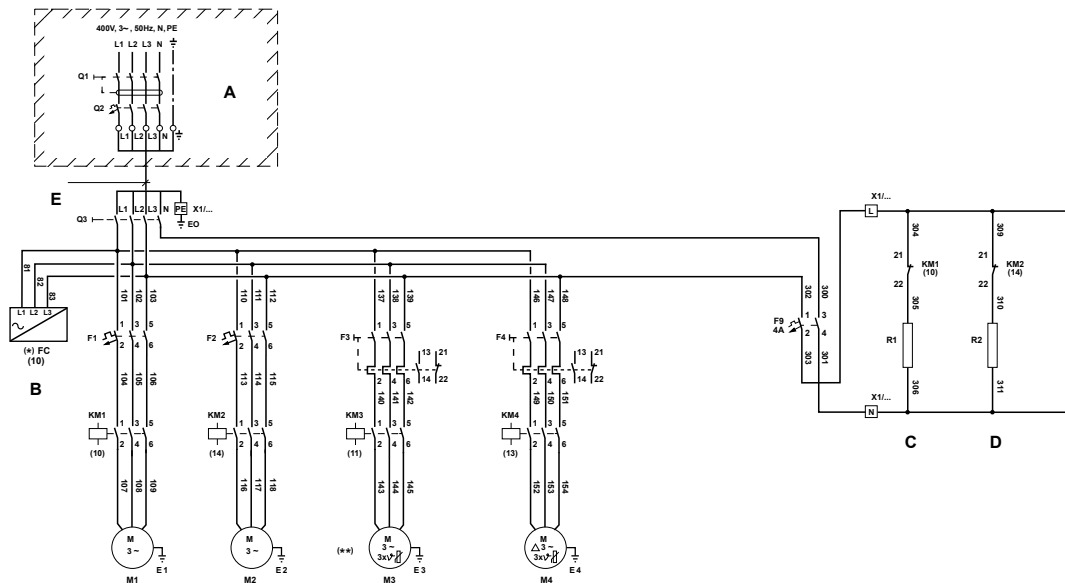

I-2599-1b (1/2)
 ARH045
 ARC045

Model	Q2 [A]	E	F1 [A]	F2 [A]	F3 [A] REG.	F4 [A] REG.
045	50	5 x 10	16	16	6,8	4

(*) If the unit has power and the green LED V2 on board A1 is off, check that the sequence of phases L1, L2, L3 is correct

A	On-site installation. These components are not supplied by the manufacturer
B	Phase control
C	Crankcase heater 1
D	Crankcase heater 2
E	Cross-section B [mm²]
M1	Compressor 1
M2	Compressor 2
M3	Supply fan
M4	Outdoor fan 1

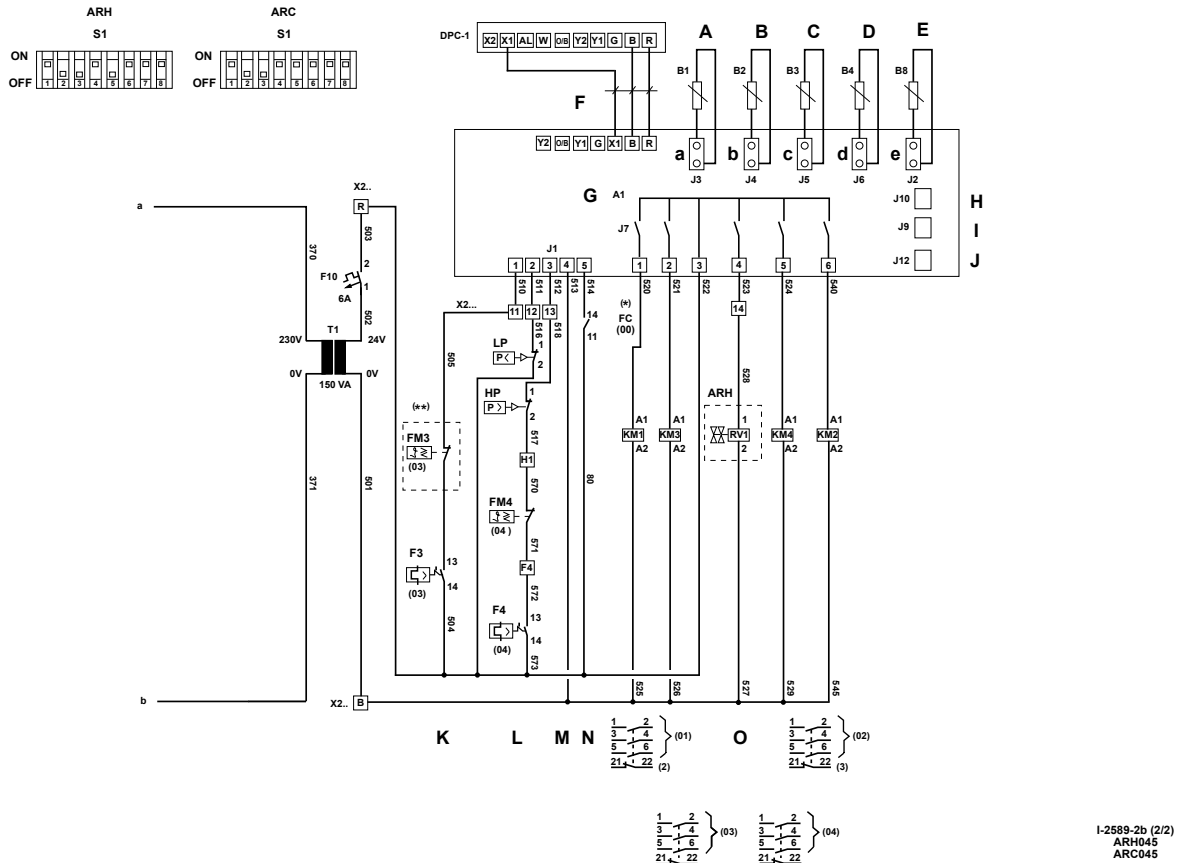

(**) Optional internal thermal switch

A	Suction probe [B1]	L	High and low-pressure switch 1
B	Liquid probe [B2]	M	Outdoor fan motor trip switch 1
C	Discharge probe [B3]	N	Compressor protection 1
D	Outdoor probe [B4]	O	4-way valve 1
E	Supply probe [B8]	S1	S1 configuration on A1 board
F	Shielded cable, 10 x 0.22 mm ²	DPC-1	Thermostat
G	Electronic board [A1]	a	Black connector [J3]
H	Accessories connection [J10]	b	Green connector [J4]
I	YKTOOL connection [J9]	c	White connector [J5]
J	RS-485 connection [J12]	d	Yellow connector [J6]
K	Indoor fan motor trip switch	e	Red connector [J2]

4 Wiring diagrams
4.5 Unit wiring diagrams

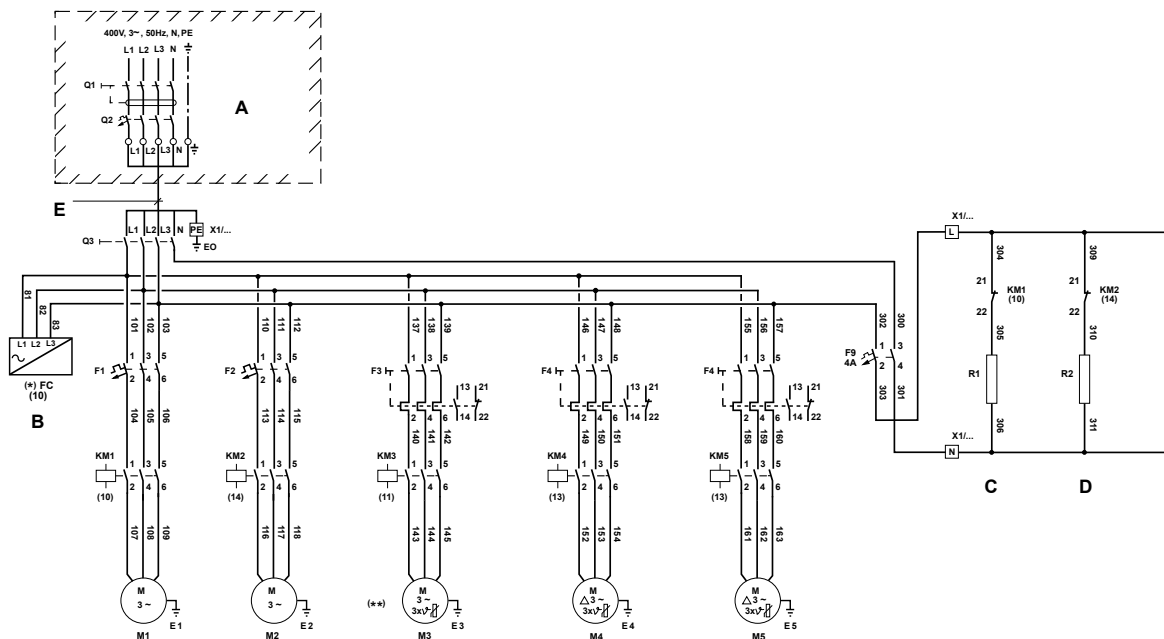

I-2613-1c (1/2)
ARH060, 075 y 090
ARC060, 075 y 090

(*) If the unit has power and the green LED V2 on board A1 is off, check that the sequence of phases L1, L2, L3 is correct

Model	Q2 [A]	E	F1 [A]	F2 [A]	F3 [A] REG.	F4 [A] REG.	F5 [A] REG.
060	63	5 x 16	25	25	9,5	4	4
075	80	5 x 25	32	32	12	4	4
090	100	5 x 35	32	32	16	4	4

A	On-site installation. These components are not supplied by the manufacturer
B	Phase control
C	Crankcase heater 1
D	Crankcase heater 2
E	Cross-section B [mm ²]
M1	Compressor 1
M2	Compressor 2
M3	Supply fan
M4, M5	Outdoor fan 1

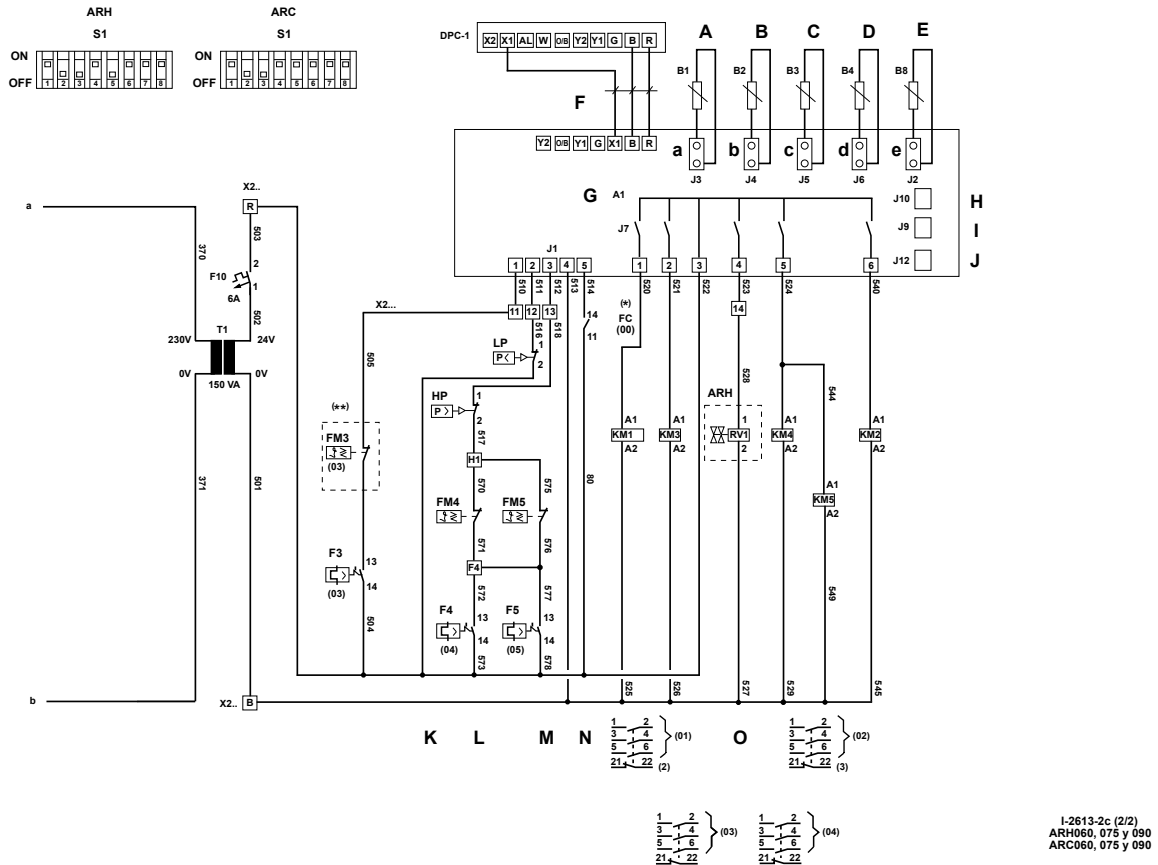

(**) Optional internal thermal switch

A	Suction probe [B1]	L	High and low-pressure switch 1
B	Liquid probe [B2]	M	Outdoor fan motor trip switch 1
C	Discharge probe [B3]	N	Compressor protection 1
D	Outdoor probe [B4]	O	4-way valve 1
E	Supply probe [B8]	S1	S1 configuration on A1 board
F	Shielded cable, 10 x 0.22 mm ²	DPC-1	Thermostat
G	Electronic board [A1]	a	Black connector [J3]
H	Accessories connection [J10]	b	Green connector [J4]
I	YKTOOL connection [J9]	c	White connector [J5]
J	RS-485 connection [J12]	d	Yellow connector [J6]
K	Indoor fan motor trip switch	e	Red connector [J2]

4 Wiring diagrams
4.5 Unit wiring diagrams

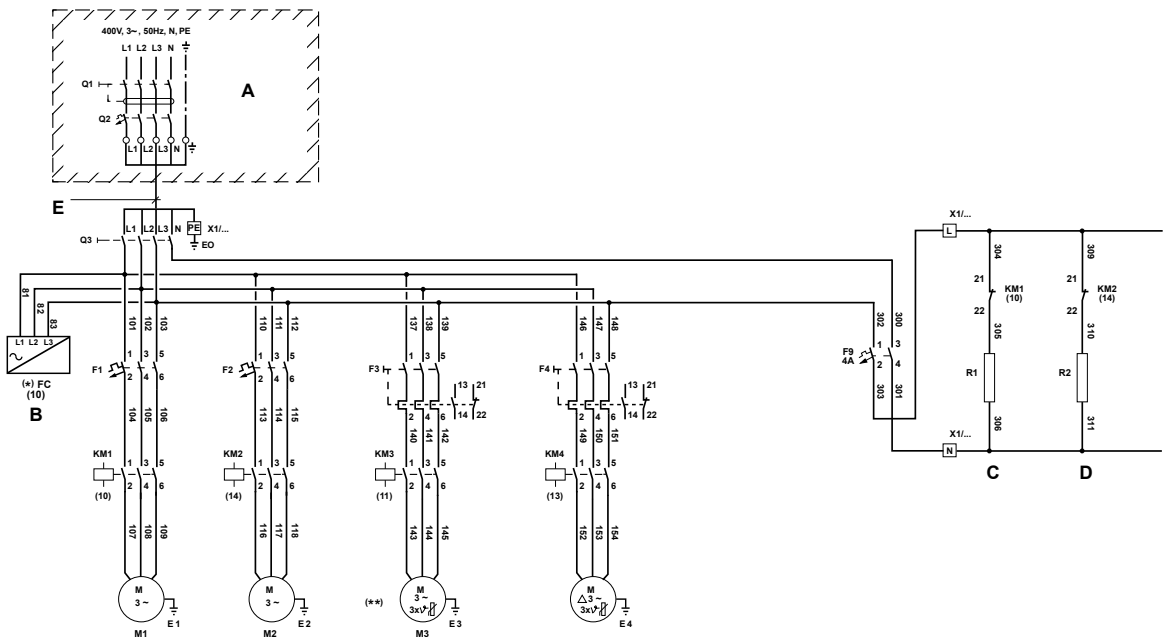

I-2615-1a (1/3)
ARG045
ARD045

Model	Q2 [A]	E	F1 [A]	F2 [A]	F3 [A] REG.	F4 [A] REG.
045	50	5 x 10	16	16	6,8	4

(*) If the unit has power and the green LED V2 on board A1 is off, check that the sequence of phases L1, L2, L3 is correct

A	On-site installation. These components are not supplied by the manufacturer
B	Phase control
C	Crankcase heater 1
D	Crankcase heater 2
E	Cross-section B [mm ²]
M1	Compressor 1
M2	Compressor 2
M3	Supply fan
M4	Outdoor fan 1

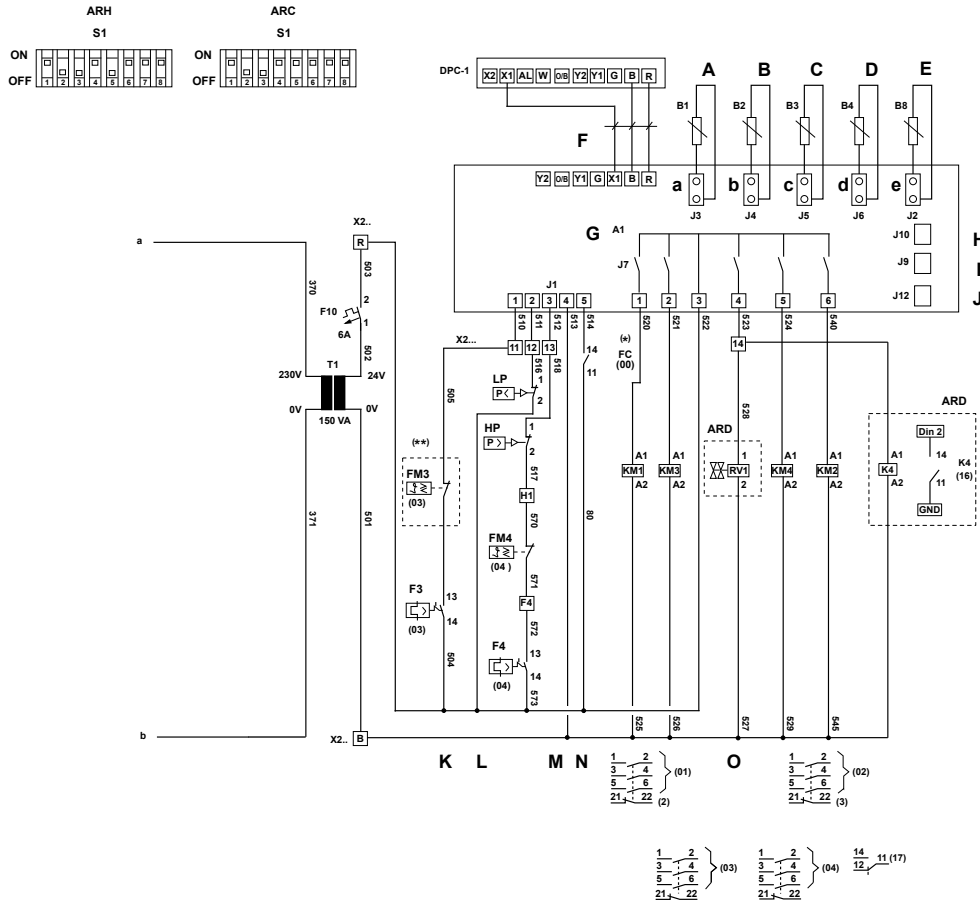

I-2615-2a (2/3)
ARG045
ARD045

(**) Optional internal thermal switch

A	Suction probe [B1]	L	High and low-pressure switch 1
B	Liquid probe [B2]	M	Outdoor fan motor trip switch 1
C	Discharge probe [B3]	N	Compressor protection 1
D	Outdoor probe [B4]	O	4-way valve 1
E	Supply probe [B8]	S1	S1 configuration on A1 board
F	Shielded cable, 10 x 0.22 mm ²	DPC-1	Thermostat
G	Electronic board [A1]	a	Black connector [J3]
H	Accessories connection [J10]	b	Green connector [J4]
I	YKTOOL connection [J9]	c	White connector [J5]
J	RS-485 connection [J12]	d	Yellow connector [J6]
K	Indoor fan motor trip switch	e	Red connector [J2]

4 Wiring diagrams
 4.5 Unit wiring diagrams

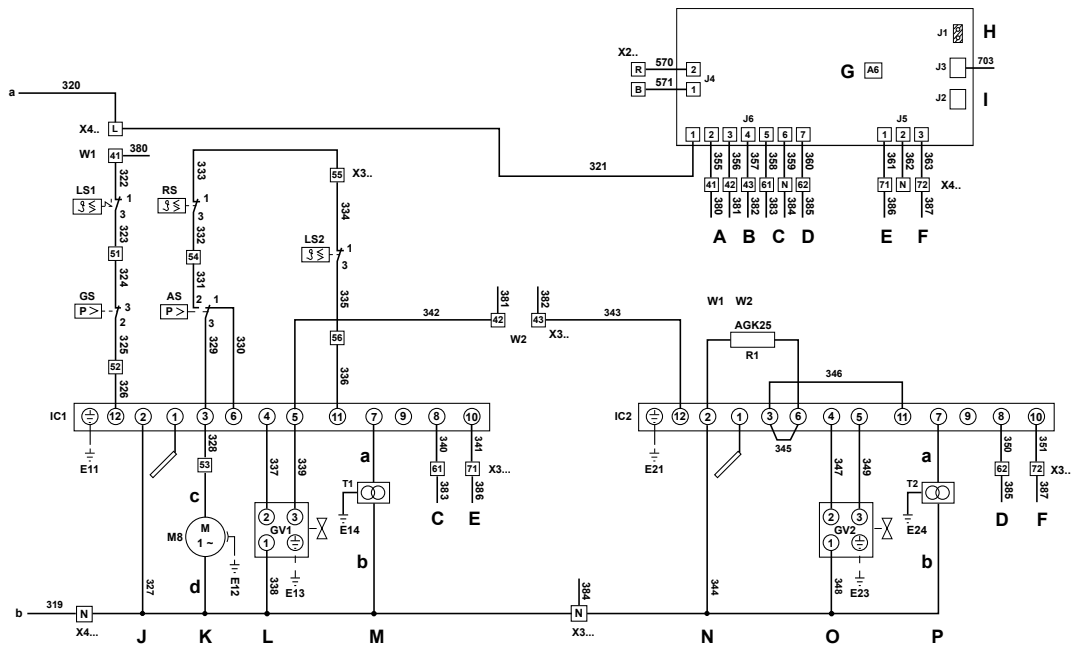

I-2615-3a (3/3)
 ARG045
 ARD045

A	Gas stage 1	K	Smoke outlet motor
B	Gas stage 2	L	Gas valve 1
C	Reset gas 1	M	Ignition transformer 1
D	Reset gas 2	N	Flame sensor 2
E	Gas alarm 1	O	Gas valve 2
F	Gas alarm 2	P	Ignition transformer 2
G	Electronic board [A6]	a	Brown cable
H	Bridge on J1	b	Blue cable
I	Accessories connection [J12]	c	Black wire
J	Flame sensor 1	d	White wire

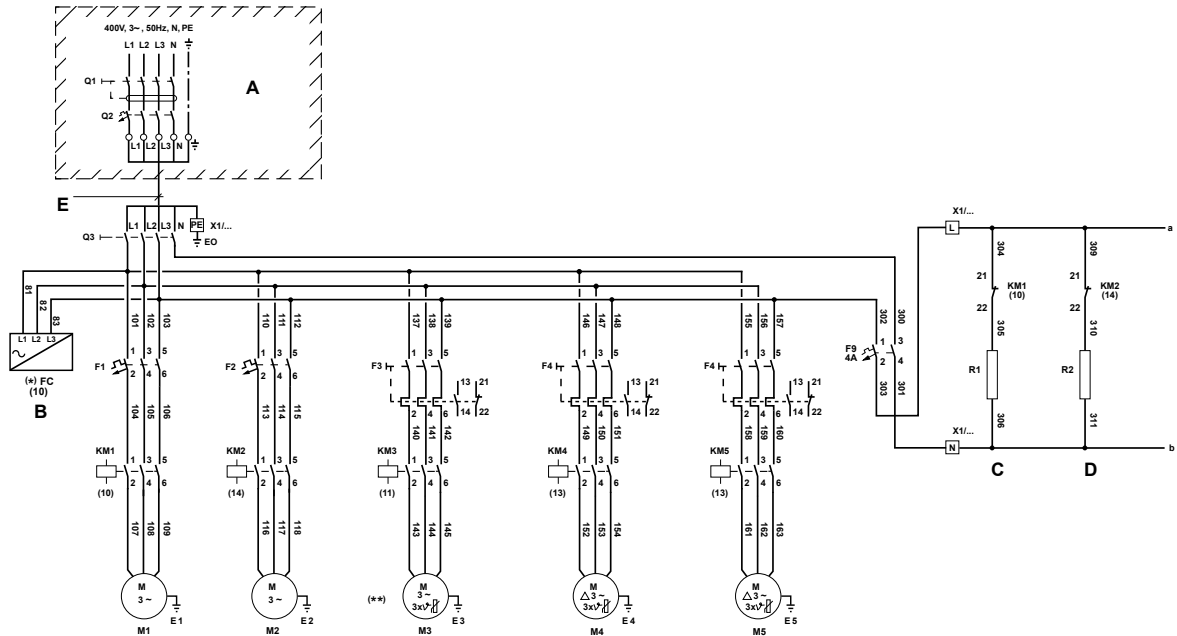

I-2816-1a (1/3)
AR0660, 075 y 090
ARD060, 075 y 090

Model	Q2 [A]	E	F1 [A]	F2 [A]	F3 [A] REG.	F4 [A] REG.	F5 [A] REG.
060	63	5 x 16	25	25	9,5	4	4
075	80	5 x 25	32	32	12,5	4	4
090	100	5 x 35	32	32	16	4	4

(*) If the unit has power and the green LED V2 on board A1 is off, check that the sequence of phases L1, L2, L3 is correct

A	On-site installation. These components are not supplied by the manufacturer
B	Phase control
C	Crankcase heater 1
D	Crankcase heater 2
E	Cross-section B [mm ²]
M1	Compressor 1
M2	Compressor 2
M3	Supply fan
M4, M5	Outdoor fan 1

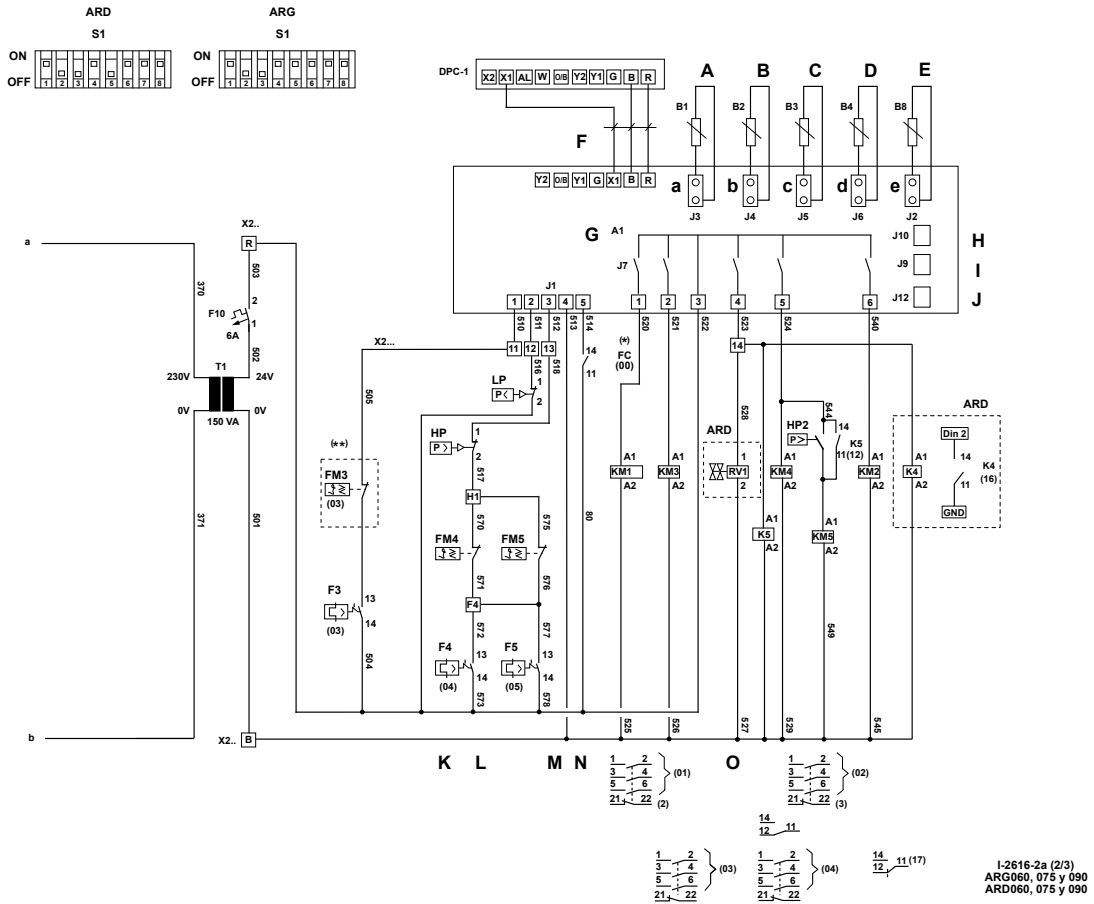

(**) Optional internal thermal switch

A	Suction probe [B1]	L	High and low-pressure switch 1
B	Liquid probe [B2]	M	Outdoor fan motor trip switch 1
C	Discharge probe [B3]	N	Compressor protection 1
D	Outdoor probe [B4]	O	4-way valve 1
E	Supply probe [B8]	S1	S1 configuration on A1 board
F	Shielded cable, 10 x 0.22 mm ²	DPC-1	Thermostat
G	Electronic board [A1]	a	Black connector [J3]
H	Accessories connection [J10]	b	Green connector [J4]
I	YKTOOL connection [J9]	c	White connector [J5]
J	RS-485 connection [J12]	d	Yellow connector [J6]
K	Indoor fan motor trip switch	e	Red connector [J2]

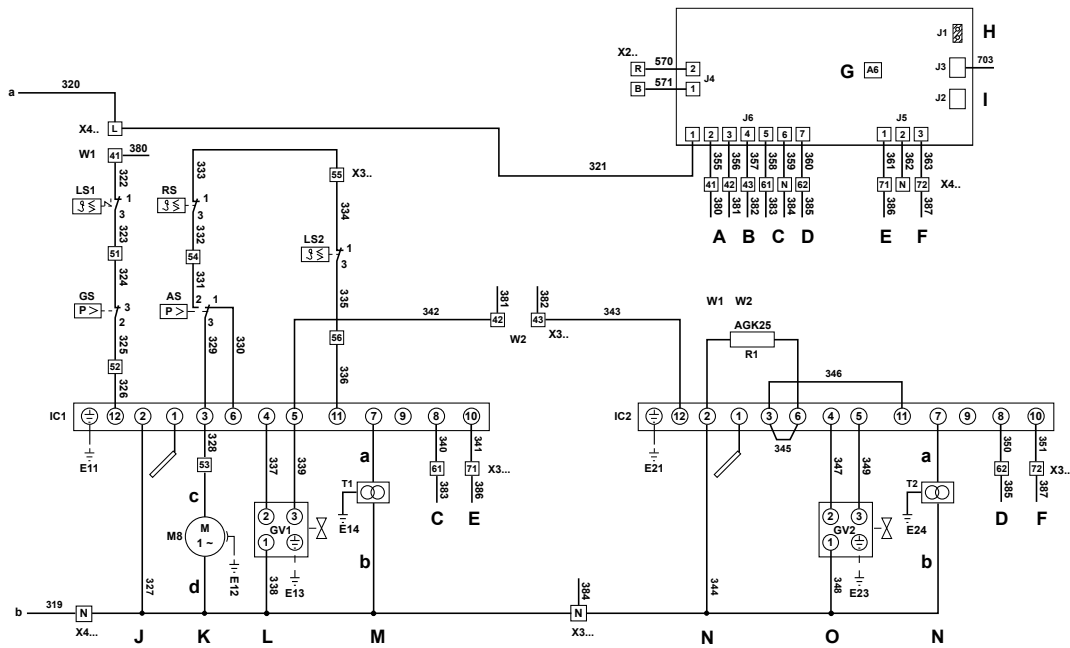

I-2616-3a (3/3)
ARG060, 075 y 090
ARD060, 075 y 090

A	Gas stage 1	K	Smoke outlet motor
B	Gas stage 2	L	Gas valve 1
C	Reset gas 1	M	Ignition transformer 1
D	Reset gas 2	N	Flame sensor 2
E	Gas alarm 1	O	Gas valve 2
F	Gas alarm 2	P	Ignition transformer 2
G	Electronic board [A6]	a	Brown cable
H	Bridge on J1	b	Blue cable
I	Accessories connection [J12]	c	Black wire
J	Flame sensor 1	d	White wire