

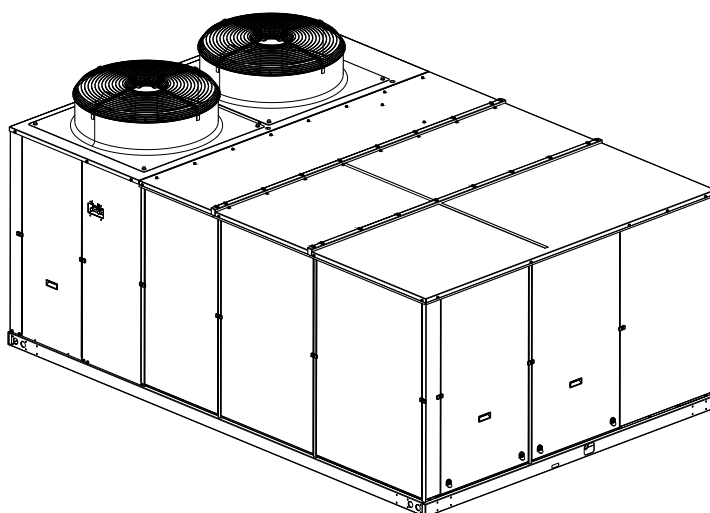

BY JOHNSON CONTROLS

# ACTIVA SERIES ROOF TOP Air Conditioners 045/090



## Quick installation guide

Ref.: N-40317\_EN 0112



# Index

<b>1</b>	<b>Quick installation guide.....</b>	<b>1</b>
<b>1.1</b>	<b>Safety instructions.....</b>	<b>2</b>
<b>1.2</b>	<b>Icons used in this document.....</b>	<b>2</b>
<b>1.3</b>	<b>Unit loading and unloading instructions.....</b>	<b>3</b>
1.3.1	Delivery inspection.....	3
1.3.2	Loading and unloading of the unit.....	3
1.3.3	Centre of gravity of the unit.....	4
1.3.4	Disposal of packaging.....	4
<b>1.4</b>	<b>Measurements, clearances and accesses.....</b>	<b>5</b>
1.4.1	Connections for supply and return side ducts.....	5
1.4.2	General dimensions and accesses (models 045/060).....	7
1.4.3	General dimensions and accesses (models 075/090).....	9
<b>1.5</b>	<b>Instructions for installation and connection of the unit.....</b>	<b>10</b>
1.5.1	Characteristics of the location.....	10
1.5.2	Characteristics of the facility where the unit will be installed.....	11
1.5.3	Characteristics of utility provider connections.....	11
1.5.4	Connection and preparation of the various connections.....	12
<b>1.6</b>	<b>Instructions for starting up the unit.....</b>	<b>17</b>
1.6.1	Start-up, ARC and ARH models.....	17
1.6.2	Additional aspects for starting the gas heating, ARG/ARD.....	18
<b>1.7</b>	<b>Unblocking the unit safely in case of breakdown.....</b>	<b>21</b>
<b>1.8</b>	<b>Unit installation data.....</b>	<b>21</b>
1.8.1	List of tests for unit start-up.....	22
1.8.2	Start-up data.....	23

1

---

## Quick installation guide

## 1.1 Safety instructions

This document contains the necessary information for the safe and efficient transportation, assembly and installation of the air conditioning unit. This guarantees the condition of the unit and its operating safety.

Only an authorised company may assemble the air conditioning unit.



### ATTENTION

*Only authorised companies with the appropriate technical resources and suitably trained personnel may install the air conditioning unit.*



### CAUTION

*The specialists responsible for installing the air conditioning unit must make sure they have all of the information and knowledge required to correctly install, test and deliver the unit. Johnson Controls Inc. shall not be considered responsible for any damage caused by installation of the unit that is not consistent with that described in this document or others specifically provided with the unit.*

During regular equipment installation, the fitter must pay special attention to certain situations in order to prevent injuries or damage to the unit.

Situations that could jeopardise the safety of the fitter or that of others nearby or that could put the unit itself at risk are clearly indicated in this manual.

A series of special symbols are used to clearly identify these situations.

Pay careful attention to these symbols and to the messages following them, as your safety and the safety of others depends on it.

## 1.2 Icons used in this document



### DANGER

- *The text following this symbol contains information and instructions relating directly to your safety and physical wellbeing.*
- *Not taking these instructions into account could lead to serious, very serious or even fatal injuries to you and others in the proximities of the unit.*

Information can also be found on safe procedures during unit handling. This will help reduce the risk of accidents.



### CAUTION

- *The text following this symbol contains information and instructions relating directly to your safety and physical wellbeing.*
- *Not taking these instructions into account could lead to minor injuries to you and others in the proximities of the unit.*
- *Not taking these instructions into account could lead to unit damage.*

Information can also be found on safe procedures during unit handling. This will help reduce the risk of accidents.



### NOTE

- *The text following this symbol contains information or instructions that may be of use or that is worthy of a more thorough explanation.*
- *Instructions regarding inspections to be made on unit parts or systems may also be included.*

## 1.3 Unit loading and unloading instructions

### 1.3.1 Delivery inspection

The unit should be carefully inspected for visible damage or abnormalities as soon as it is received.

Any abnormalities or damage to the unit should be communicated to both the transportation and insurance company in writing.

### 1.3.2 Loading and unloading of the unit

The units should only be handled by personnel from the company responsible for their installation.

Loading and unloading the unit from a truck or trailer should be on flat, solid ground using an appropriate crane with sufficient capacity.



#### CAUTION

*It is strictly prohibited to use fork lifts to load, unload, or handle the unit.*

The points designed for hoisting the unit are located on the beams on its base **-arrows-**.

Before hoisting the unit, check that the cables or slings are firmly hooked to these points and make sure the crane and the cables or slings are capable of lifting the weight.

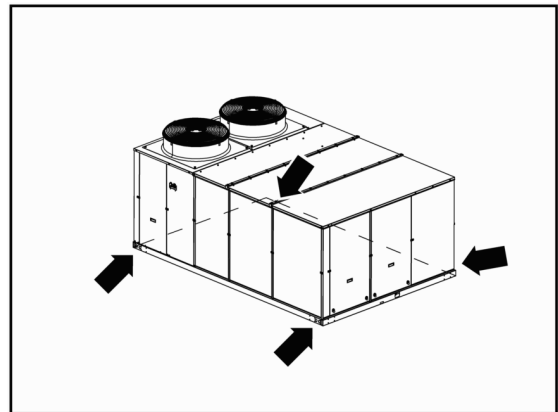

Place spacers **-1-** at the top of the unit to prevent the cables or slings from touching it.

Attach guide ropes so that the unit does not rotate freely.

The cables or slings should be long enough to form an angle of over 45° to the horizontal plane. Hoist the unit keeping it in a horizontal position.

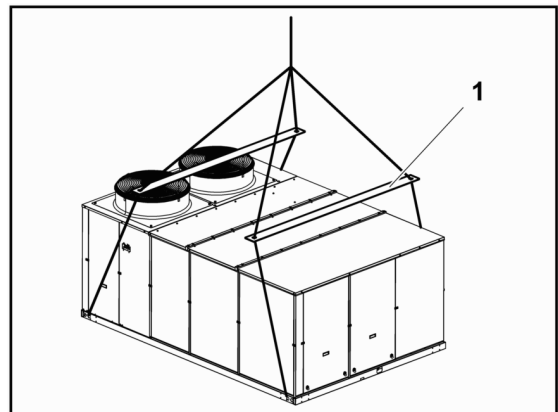

#### DANGER

*There should not be onlookers within a radius of 10 m of the unit when it is being hoisted.*

### 1.3.3 Centre of gravity of the unit

Models	045	060	075	090
A	1180	1180	1135	1080
B	1390	1425	1480	1540
C	3180	3180	3495	3495
D	2337	2337	2337	2337

All measurements in mm.

1. Centre of gravity
2. End of the outdoor coil

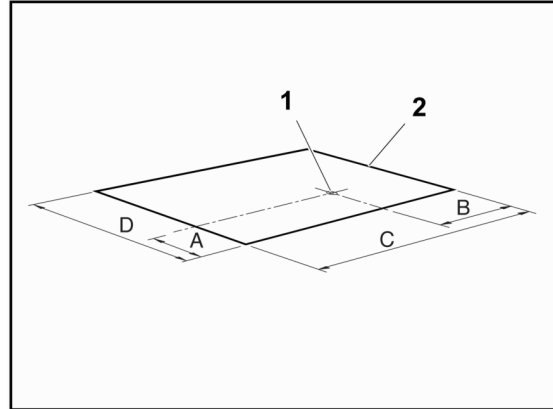

### 1.3.4 Disposal of packaging

The packaging is recyclable. Dispose of it in the appropriate place or take it to an appropriate collection centre. Respect the regulations in force for this type of waste in the country where the unit is being installed.

Packaging remains must be correctly disposed of. Improper disposal of packaging generates environmental problems that affect human life.

## 1.4 Measurements, clearances and accesses

### 1.4.1 Connections for supply and return side ducts

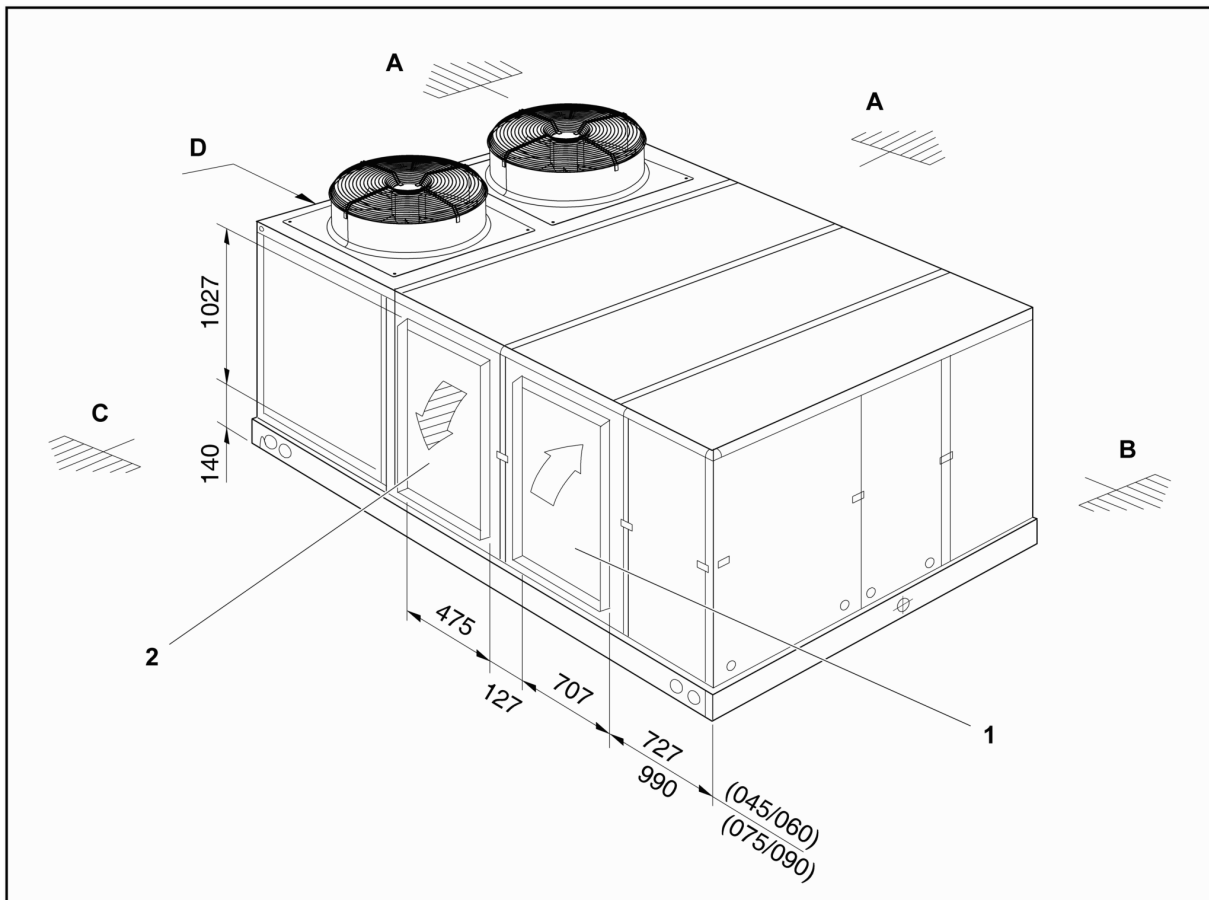

#### Minimum clearance

- A. Minimum clearance: 900 mm
- B. Minimum clearance: 600 mm (without economiser); 1200 mm (with economiser)
- C. Minimum clearance: 600 mm (without economiser); 1245 mm (with economiser)
- D. Outdoor coil
- 1. Return air
- 2. Supply air

Units are shipped with the lower duct openings covered.

### **For applications with downward airflow ducts:**

1. In order to access the covers of the lower supply and return air ducts, remove the side panels of the supply and return air compartments.
2. Remove and discard the lower duct covers.
3. Replace the side panels of the supply and return air compartments. Make sure that the seal is completely air-tight and check that the screws that fasten the panel have their corresponding o-rings.

### **For applications with sideways airflow ducts:**

Flanges for connecting the side ducts are included in an accessory kit.

1. Replace the side panels of the supply and return air compartments with the set of accessory panels. Make sure that the seal is air-tight.
2. Connect the duct system to the panel flanges.

### **Minimum clearance above the unit**

The unit is designed to be installed outdoors.

In ground level installations, the building eaves should be at a vertical distance of at least 1830 mm from the top of the unit and should not overhang the unit more than 915 mm.

There are no restrictions regarding the overhang if the eaves are 3000 mm or more above the unit.

### 1.4.2 General dimensions and accesses (models 045/060)

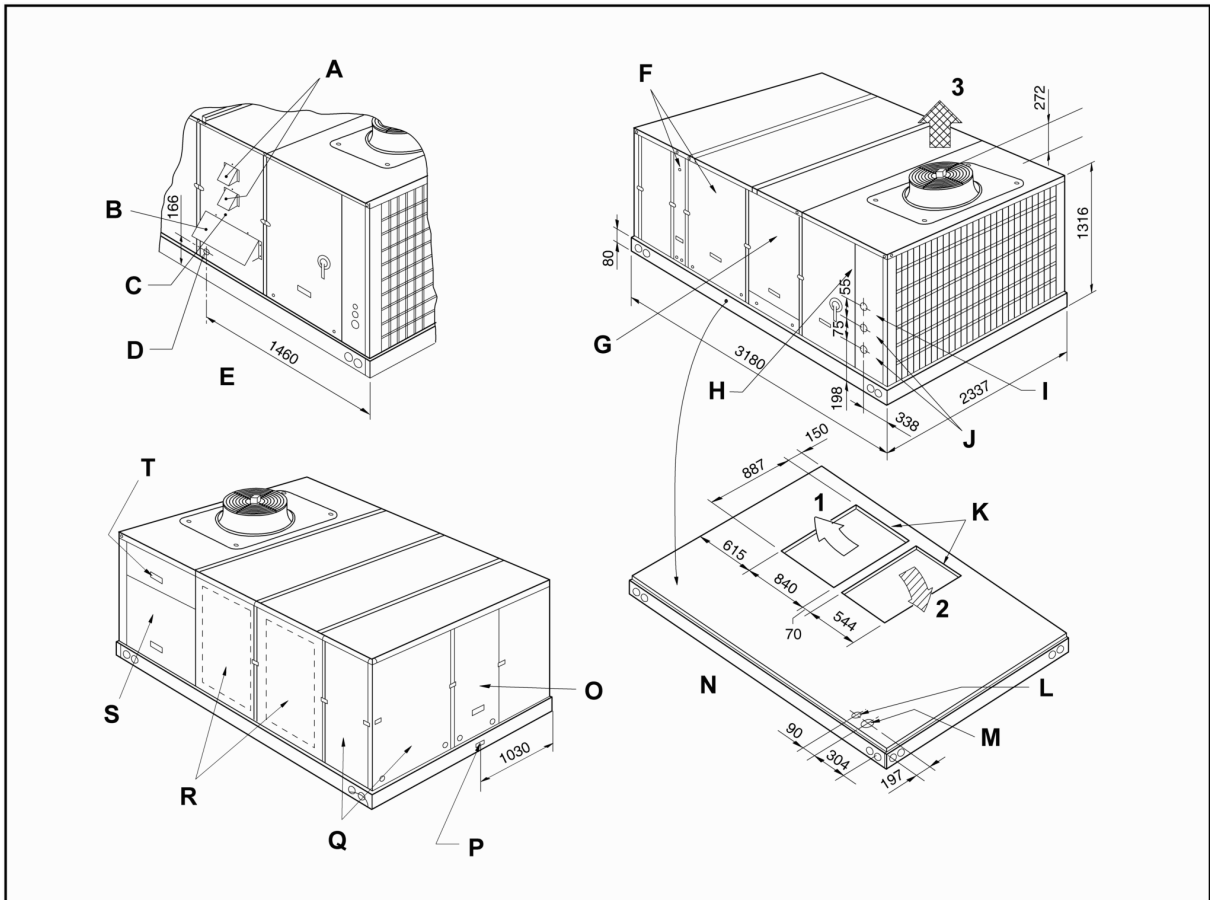

## 1 Quick installation guide

### 1.4 Measurements, clearances and accesses

- A. Combustion gas outlet hood
- B. Combustion air input hood
- C. Access to gas heating system
- D. Gas supply intake ( $\varnothing$  58 mm), with rubber grommet
- E. RAG/RAD unit details
- F. Access to motor, fan and pulleys
- G. Access to heating options
- H. Access to control system
- I. Control cable intake ( $\varnothing$  23 mm) (side)
- J. Power cable intake ( $\varnothing$  38 + 29 mm) (side)
- K. Opening for connection of lower supply and return air ducts.
- L. Control cable intake (PG 21 mm) (lower)
- M. Power cable intake (PG 48 mm) (lower)
- N. Close-up of the base, shown separately to be more easily seen
- O. Access to filters and indoor coil
- P. Condensate drain connection (1" BSP Female)
- Q. Access to the outdoor air compartment
- R. Supply and return air compartment side panels See [Connections for supply and return side ducts, ver pág. 5](#)
- S. Compressor access
- T. Pressure reading connection
  - 1. Return air
  - 2. Supply air
  - 3. Condensate air

### 1.4.3 General dimensions and accesses (models 075/090)

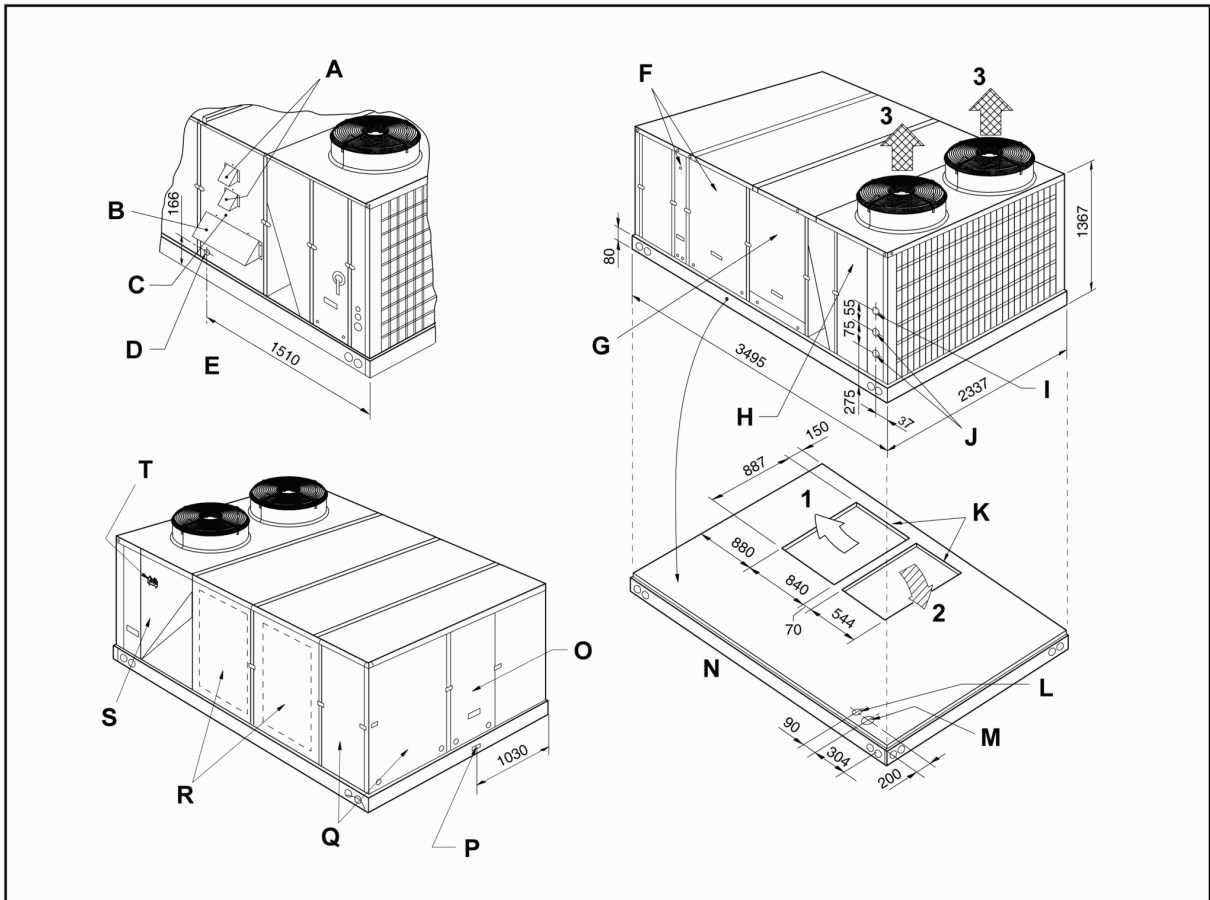

## 1.5 Instructions for installation and connection of the unit

- A. Combustion gas outlet hood
- B. Combustion air input hood
- C. Access to gas heating system
- D. Gas supply intake ( $\varnothing$  58 mm), with rubber grommet
- E. RAG/RAD unit details
- F. Access to motor, fan and pulleys
- G. Access to heating options
- H. Access to control system
- I. Control cable intake ( $\varnothing$  23 mm) (side)
- J. Power cable intake ( $\varnothing$  38 + 29 mm) (side)
- K. Opening for connection of lower supply and return air ducts.
- L. Control cable intake (PG 21 mm) (lower)
- M. Power cable intake (PG 48 mm) (lower)
- N. Close-up of the base, shown separately to be more easily seen
- O. Access to filters and indoor coil
- P. Condensate drain connection (1" BSP Female)
- Q. Access to the outdoor air compartment
- R. Supply and return air compartment side panels See [Connections for supply and return side ducts](#), ver pág. 5
- S. Compressor access
- T. Pressure reading connection
  - 1. Return air
  - 2. Supply air
  - 3. Condensate air

## 1.5 Instructions for installation and connection of the unit

### 1.5.1 Characteristics of the location

The location of the unit must be studied to ensure a completely satisfactory installation. To do so, the environmental conditions of the area where the unit is to be installed must be taken into account.

Furthermore, the normal weather conditions should be instrumental in determining the best position of the unit and the hoods, screens or covers required to ensure its correct working order.

If possible, in warm zones like the southern Europe, the unit should be located on the north or east side of the building or property.

The location chosen for the unit must provide the condenser with an unlimited air supply.

As well as the technical data given in this document and any others that are applicable, please bear in mind that the unit has been designed for outdoors installation only.

Where the unit is to be installed on the roof of a building or property, make sure that the roof structure can support the weight of the unit plus that of any optional equipment and/or accessories to be fitted.

The unit must be installed on a specific mounting base or on a frame of appropriate steel angles. There are optional mounting bases available (Roof-curb).

Regardless, keep the level tolerance at maximum 10 mm all along the length and width of the unit.

If the unit is to be installed on a base or on a special angle frame that is not the standard Roof-curb, gaskets should be applied to all surfaces that are touching the bottom of the unit.

If it is preferred to place the unit on shock absorbers, this should be done as described in [Connections for supply and return side ducts](#), see on page 5.

**Special instructions for locations where there is regular snowfall or with ambient temperatures of close to 0°C or less**

In areas where there is regular or sporadic snow, the unit should be elevated above the ground or roof where it is installed. The height should be enough to prevent the unit, the condenser and evaporator air inlets and the access to the unit panels from becoming blocked by accumulated snow.

**Protection against ice**

In areas where the temperature can be 0°C or less, there should be some kind of additional protection to prevent the water contained in the condensate drain pipe from freezing.

Use a wire heating element in the drain trap as well as in the drain, where applicable.

In heat pumps, also use cord resistors in the outdoor coil tray to prevent any ice from accumulating.

**Special instruction for locations with high ambient temperatures**

In areas where the ambient temperature is over 43°C, the unit must not be located in direct sunlight and, therefore a specific sunshade will be required.

The installation of a special sunshade over the unit must not affect the air flow required by the unit to work correctly. Check the minimum clearance required *Connections for supply and return side ducts, see on page 5*.

**Specifications for the foundation or anchoring of the unit**

Where the unit is to be installed at ground level, the characteristics of the ground it will sit on must be taken into account.

Characteristics, such as acceptable surface firmness, must be suitable for the foundation the unit requires.

The unit should be placed on a level concrete slab at least 100 mm thick.

The length and width of the slab must be at least 150 mm more than the base rails on the unit.

**CAUTION**

*Do not attach the unit to the foundations of the building.*

**1.5.2 Characteristics of the facility where the unit will be installed**

The air duct installation where the unit is to be installed must be formed by a closed return duct system. The additional installation of economisers or outdoor air intakes is not excluded.

To reduce operating noise, the supply and return air duct connections on the unit must be made using flexible joints.

The supply and return air duct systems must be designed for the air flow requirements of the installation. The ducts should not be sized based on the supply and return air connection sizes of the unit.

**1.5.3 Characteristics of utility provider connections**

In general, the different connections required by the unit are made following the shortest route possible. Under no circumstances may any local or national regulations be contravened when performing the preparatory work for service connections.

**NOTE**

*For further information on this subject, always keep the current regulations for the country where the unit is being installed at hand.*

**CAUTION**

- *Before the connection work, possible losses of flow, temperature and voltage drops, etc. that might affect the distances between planned connection points and the unit must be taken into account.*
- *As a result, each connection must be sized accordingly.*

**Additional specifications for the gas connection (for ARG/ARD models only)**

To correctly size the gas supply pipe, keep in mind the flow required, the specific density of the gas and the length of the stretch.

The fact that the heating value of the gas can vary from town to town should also be kept in mind. The heating value of the gas should be checked with the utility company.

**1.5.4 Connection and preparation of the various connections****Gas**

A specific line should be used for gas supply. Its installation must comply with country and local safety regulations.

**NOTE**

*For further information on this subject, always keep the current regulations for the country where the unit is being installed at hand.*

**Gas. Modification for service with LPG (Liquefied Petroleum Gas, propane gas)**

All units with gas heating are specially manufactured to operate with natural gas. The unit can be modified to operate with LPG (Liquefied Petroleum Gas, propane gas) if necessary. This involves a conversion kit that is assembled during the installation work.

A specific line should be used for gas supply. Its installation must comply with country and local safety regulations.

The LPG propane pressure must be at 37 mbar with the unit at full load for it to operate correctly.

Three main factors must be taken into consideration in order to keep the gas pressure values correct:

1. Speed of gas evaporation, which depends on:
  - a. the temperature of the liquid and
  - b. the size of the "wet surface" of the container or containers.
2. Correct pressure regulation.
3. Pressure drop in the supply lines between the regulators and the unit. The diameter of the pipe depends on its length and the total load of all units.

**NOTE**

*LPG propane gas tank and component manufacturers, as well as their suppliers, can provide complete information about the sizing of the tank in regards to evaporation, pipes, and recommended regulator adjustments.*

Important recommendations for the installation of the gas supply pipe: [Gas](#), see on page 12.

**Electricity. Power and control****POWER LINE**

Power must be supplied to the unit through a specific power supply line with an exclusive power control and differential breaker, installed in line with national and local regulations.

Consult the Installation Guide for all technical data relating to unit installation.



**NOTE**

*For further information on this subject, always keep the current regulations for the country where the unit is being installed at hand.*

Make sure that the electricity supply line has enough capacity to power the unit. Its length, the cable diameter and their protection (cover or jacket) should be appropriate for the unit.

Use a multimeter to check that the supply voltage remains within the accepted limits.

To install the power cable, loosen the closures -1- by 1/4 turn and remove the electrical board panel.

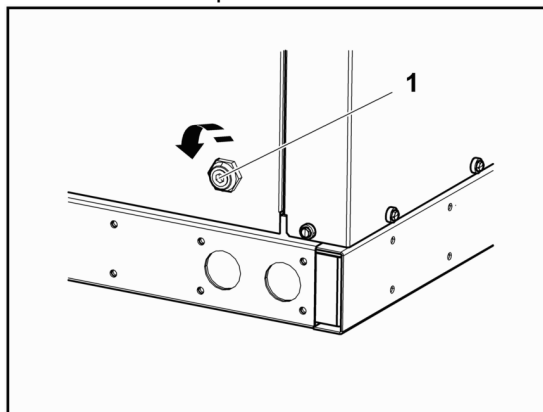

**Bringing the power and control cables directly from the Roof-curb**

Remove the protective plate -1-.

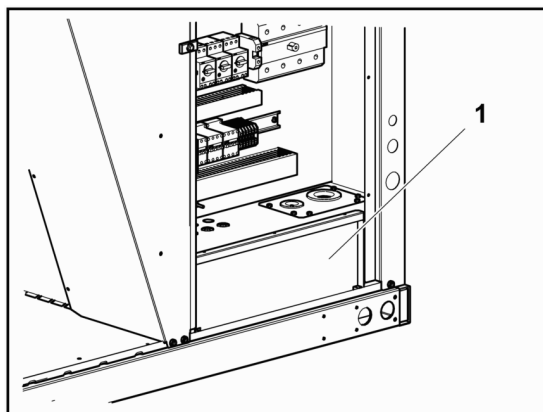

Pull the cables through the gland at the base of the unit -1- and -5-.

Pull the cables towards the electrical panel through the grommets -2- and -4-.

Seal the glands with silicone to ensure they are leak-proof.

Replace the protective plate.

**Passing the power and control cables through the front of the unit.**

Exchange the position of the side cover -3- and the plate that has the grommets -2- and -4-.

Press the appropriate openings on the edge of the unit -6- until they are released.

Place gland that fits the cable and pull the cable towards the electrical panel through the grommet -2-.

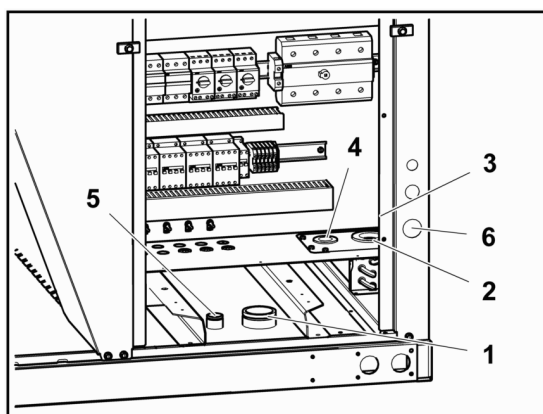

## 1.5 Instructions for installation and connection of the unit

Connect the cable to the input connections indicated and firmly tighten the securing bolts. Also consult the Wiring Diagrams.

Consult the Installation Guide for all technical data relating to unit installation.

**NOTE**

*The complete wiring diagram for the unit is attached to the inside of the electrical panel.*

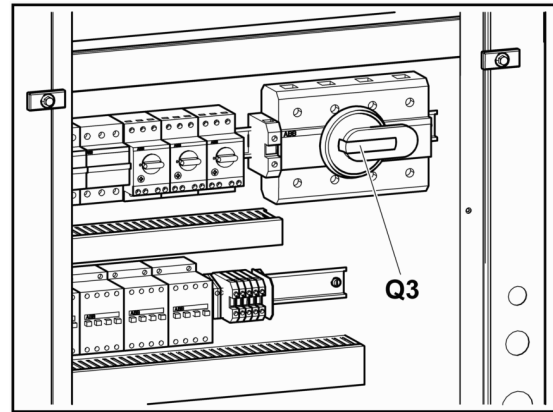

The electrical panel is fitted with a phase detector to ensure the electrical connection follows the sequence of phases R-S-T. Where the connection does not respect this sequence, the electronic control circuit remains disconnected and the unit will not start.

To correct the phase sequence, change the position of two of the three unit power cables on the input terminals.

**CONTROL LINE****Bringing the power and control cables directly from the Roof-curb**

Remove the protective plate -1-.

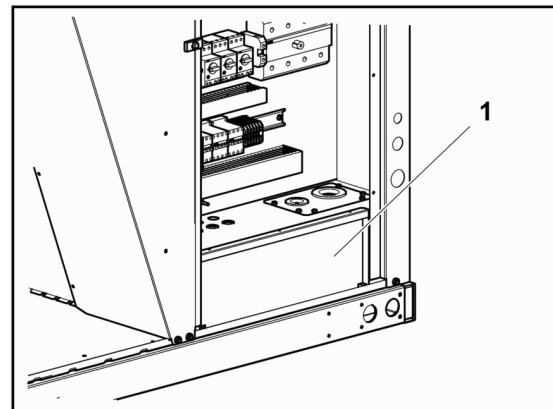

Pull the cables through the gland at the base of the unit -1- and -5-.

Pull the cables towards the electrical panel through the grommets -2- and -4-.

Seal the glands with silicone to ensure they are leak-proof.

Replace the protective plate.

**Passing the power and control cables through the front of the unit.**

Exchange the position of the side cover -3- and the plate that has the grommets -2- and -4-.

Press the appropriate openings on the edge of the unit -6- until they are released.

Place gland that fits the cable and pull the cable towards the electrical panel through the grommet -2-.

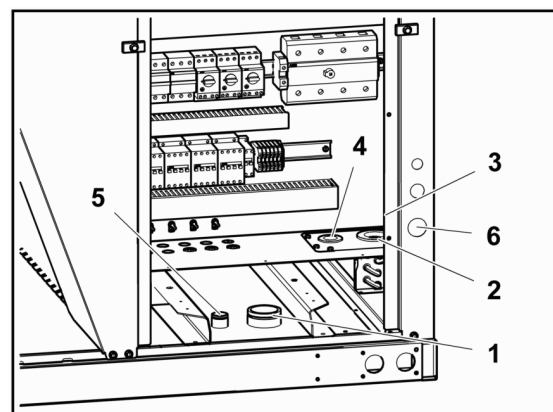

Connect the cable to the terminals indicated and firmly tighten the securing bolts. Also consult the Wiring Diagrams.



**NOTE**

*The complete wiring diagram for the unit is attached to the inside of the electrical panel.*

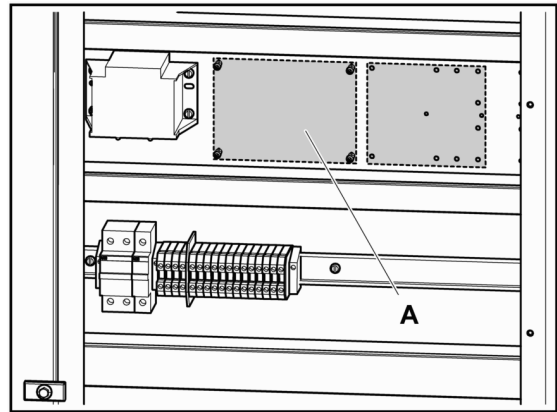

**Thermostat connections**

1. Yellow cable.
  2. Red cable.
  3. White cable.
- A. Shielded cable, 2 x 0,5 mm<sup>2</sup>. Maximum length: 100 m.
- B. Shielded cable, 10 x 0,22 mm<sup>2</sup>. Maximum length: 100 m.

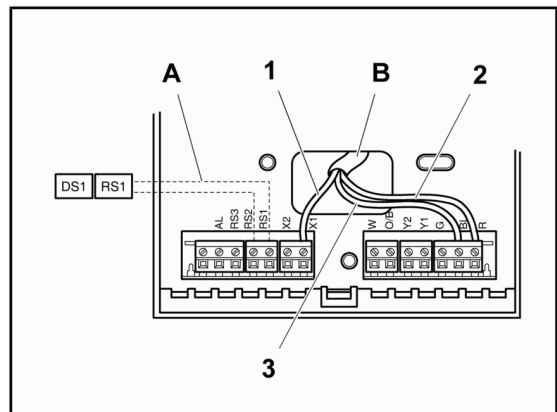

**Thermostat connections to the control board**

A. Thermostat connection board.

**Board connection terminals**

- X1. To terminal X1 of the DPC-1 thermostat.
- B. White. To terminal B of the DPC-1 thermostat.
- R. Red. To terminal R of the DPC-1 thermostat.
- W. –
- O/B –
- Y1 –

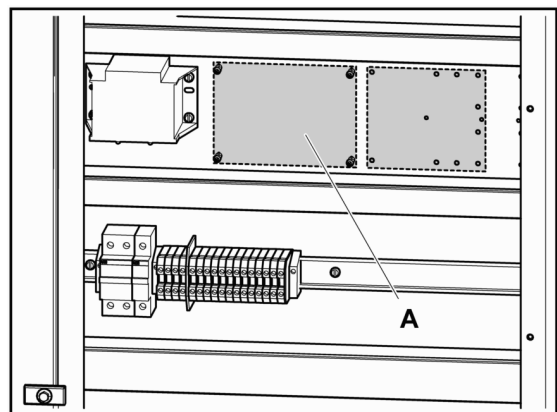

**Fan flow adjustment**



**DANGER**

- *The unit has a remote control, which means that the fan turbine may start unexpectedly.*
- *Disconnect the general switch on the unit before removing any of its side panels.*

**Belts (indoor fan)**

Check their condition and correct tensioning.

If it is necessary to replace the belts, they should be the same type and size as the originals.

### Tensioning of the belts and adjusting the pulley

All units incorporate single speed motors with belt transmission for indoor ventilation.

1. Loosen the nuts **-A-**. Never loosen the nuts **-C-**.
2. Tighten the belts by turning the screw **-B-** until the belt moves: 20...23 mm.
3. Tighten the nuts **-A-**.
4. Check the tension of the belts twice during the first 24 hours of unit operations.

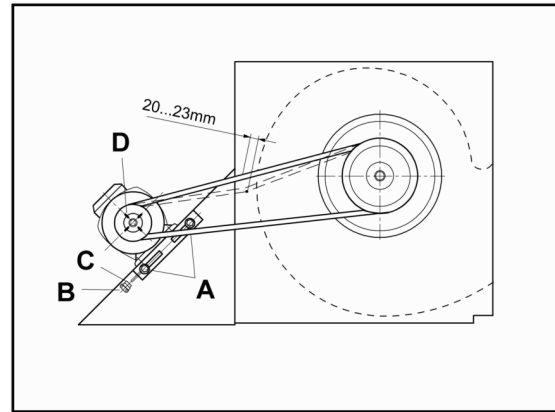

#### NOTE

*The fan motor variable diameter pulley can be adjusted in order to obtain the supply air flow desired.*

### Pulley adjustment (models 045/060/075: 1 groove; models 090: 2 grooves)

Consult the Installation Manual for the appropriate air flow adjustment values.

Loosen the nuts **-A-**. Never loosen the nuts **-C-**.

Loosen the belts by turning the screw **-B-**.

Loosen the set screws **-D-** to release the mobile rim **-E-**.

To increase or decrease the opening of the pulley, turn the mobile rim **-E-** on the thread of the fixed core of the pulley in the appropriate direction.

Apply sealant to the threads of the set screws **-D-** and fully tighten, checking that they match up to their housing in the fixed core of the pulley.

1. Pulley completely closed (maximum diameter). Maximum air flow.
2. Pulley completely open (minimum diameter). Minimum air flow.

DP Pulley diameter

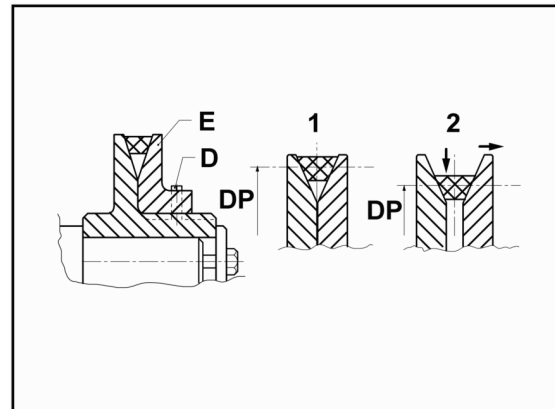

#### CAUTION

*In the case of model 090, both of the pulley grooves should be at the same distance from the fixed core of the pulley (same number of open or close turns).*

1. Pulley completely closed (maximum diameter). Maximum air flow.
2. Pulley completely open (minimum diameter). Minimum air flow.

DP Pulley diameter

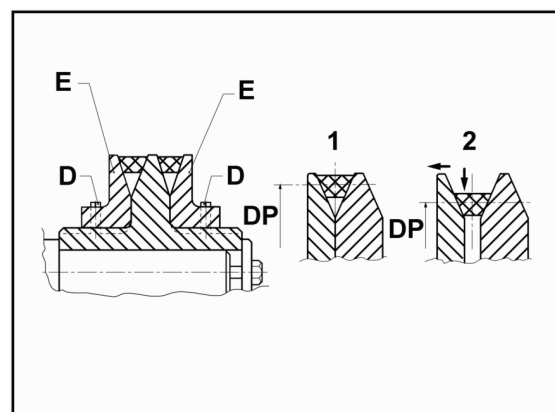

### Condensates. Insulation and/or protection of ducts

Condensates should be released by means of a specific installation in line with local or national regulations.



**NOTE**

*For further information on this subject, always keep the current regulations for the country where the unit is being installed at hand.*

Condensate drain pipes are connected using a female thread 1" BSP through an opening -1- situated on the base of the unit.

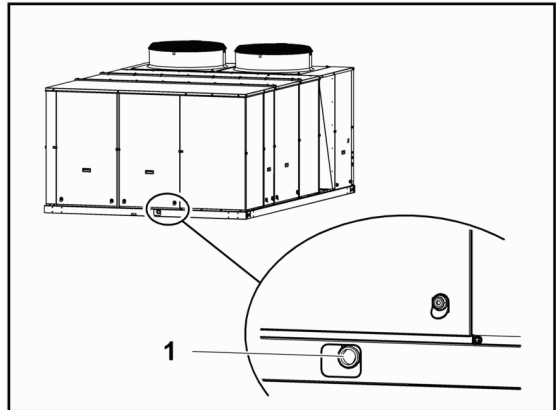

Install a drain trap on the exhaust outlet of the unit. The drain trap must have an access register -1- to facilitate emptying and cleaning when necessary.

Apply a moderate amount of sealing paste to the threads of the male part of the joint.

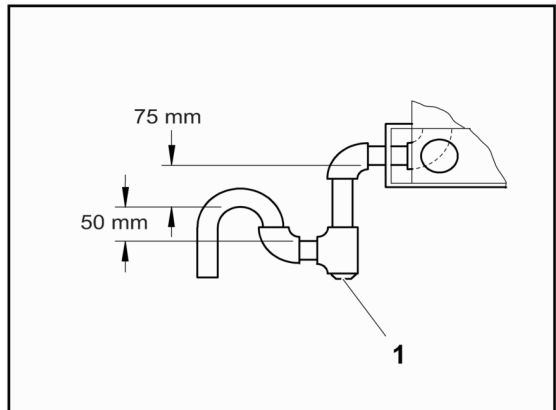

Lay the condensate drain pipe from the female connection on the bottom of the unit to a nearby drain.



**NOTE**

*The condensate drain pipe should be at a minimum gradient of 2% (2 cm of drop for each metre in length).*

## 1.6 Instructions for starting up the unit

### 1.6.1 Start-up, ARC and ARH models

#### INITIAL CONNECTION OF THE UNIT



**DANGER**

- All side panels except for that of the electrical box, must be fitted, closed and secured with their corresponding locks before turning the general switch on the unit.
- The unit has a remote control, which means that the fan turbine may start unexpectedly.



**CAUTION**

*Loose connection terminals produce overheating of cables and terminals. The unit will work incorrectly and there is a risk of fire.*

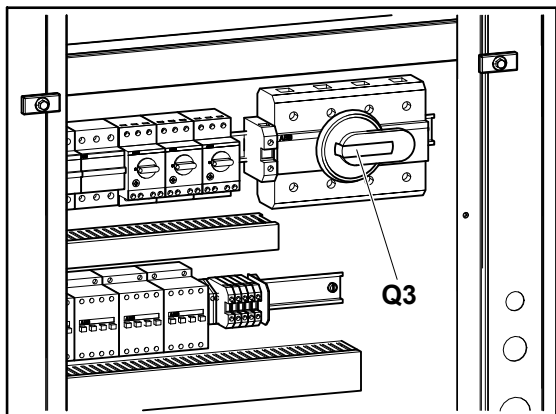

Check that the cables are firmly secured to their connection terminals.



**CAUTION**

*Do not turn on the general switch on the unit or start the unit until all installation work has been completed.*

The general switch on the unit **-Q3-** must be turned on once all of the planned accessories are installed and before starting the unit.

Press the "Test"-**1-** button for two seconds so that the unit recognises the installed accessories. When the recognition process is complete, the red pilot light **-2-** switches off.

**Rotating direction of the Scroll compressors**

The scroll compressors and the fans only operate correctly if they rotate in the correct direction. All of the motors and compressors in the unit are connected so that they rotate correctly.

If the compressors are not connected correctly and are rotating in the wrong direction:

- The compressor will not compress.
- Operating noise will be abnormal.
- Electricity consumption (A) will be low.
- They overheat.

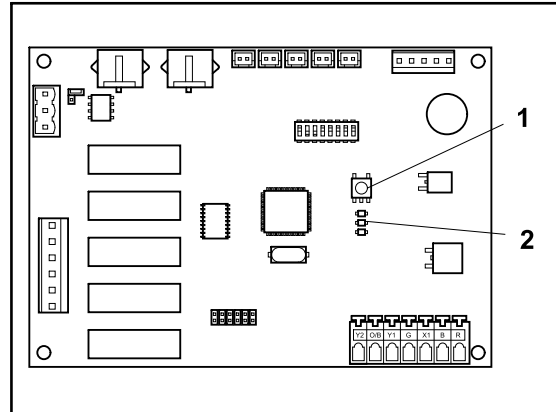

**NOTE**

*Consult the User Manual for further information on unit operations.*

## 1.6.2 Additional aspects for starting the gas heating, ARG/ARD



**DANGER**

- *In order to prevent damage to the gas valves, the burner group should be disconnected from the gas pipe system during the pressure test.*
- *Only an Authorised Technical Assistance Service for Johnson Controls Inc. with the appropriate technical resources and adequately trained personnel may perform the start-up tasks for gas heating on the unit.*

### Prior checks

1. Check that the type of gas to be used is the same as that specified on the ticket situated to the left of the gas section access panel.
2. Check that the covers for the gas outlets and the combustion air intake have been correctly installed by checking the Installation Manual.
3. Check that the combustion air inlet is free of obstruction from dirt, snow, branches, dry leaves, residue or other objects.
4. Make sure the gas supply line complies with safety regulations, that it is able to supply an adequate flow and pressure of gas, and that it has been purged of air. See [Gas](#), see on page 12, or [Gas Modification for service with LPG \(Liquefied Petroleum Gas, propane gas\)](#), see on page 12.

### On

The burner is equipped with an automatic lighting system.



**DANGER**

*Do not try to start the burner manually.*

## Start-up without the portable YKTOOL test device (accessory)

1. Connect the electrical supply to the unit.
2. Open the unit's gas supply valve.
3. Place the ambient thermostat in the maximum heat.



### NOTE

*See the User Manual for further information on thermostat operations.*

4. The burner group should light (it might take a few minutes depending on the mode established in the thermostat)

## Post start-up checks

Once the entire control circuit is activated and the heating section is operating, the following checks should be made:

1. Make sure there are no gas leaks either in the unit's pipes or in the supply pipes.



### DANGER

*Never use a flame to verify the absence of leaks in the installation joints. DANGER OF EXPLOSION.*

2. Check that the pressure of the supply gas is within the limits designated on the rating plate.
3. The supply pressure at full output should be checked for all gas appliances in the building.
4. Pressure in the gas supply line should never exceed 25 mbar. In units powered by natural gas, the operating pressure should never fall below 12,5 mbar.



### NOTE

*If the gas supply is outside these limits, contact the gas utility company or your local representative for corrective measures.*

5. Check that gas pressure in the manifold is correct. See [Adjust gas valves / thermal breaker](#), see on page 19.

## Adjust gas valves / thermal breaker

ARD/ARG Models:		045, 060, 075, 090	
Burner model	N320		
Heating capacity (kW)	Total (LHV)	Standard	85
		Optional high power	100
	Net	Standard	76
		Optional high power	90
Gas family	2ND-H/E (G20)	2ND-L (G25)	
Gas valve adjustment (mbar)	Main regulator	10,5	15,2
	Second stage regulator	–	–
	Stage regulator	9,9	14,6
Thermal breaker limits (°C)	Automatic reset	82	
	Manual reset	93	

LHV: Lower heating value.

- A. Main regulator adjustment
- B. Connection flange
- C. Spigot for reading inlet pressure

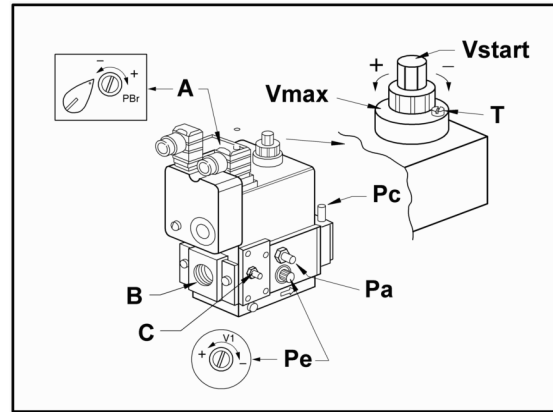

## Gas pressure regulation in the burner supply manifold

The units are manufactured and regulated for the 2ND-H (G-20) natural gas family.

Gas is regulated depending on the type of gas used, follow the steps below and adjust the two valves according to the values specified in [Adjust gas valves / thermal breaker](#), see on page 19.



### CAUTION

*The gas valve in units converted to LPG (Liquid Petroleum Gas, propane) should be regulated according to the technical instructions included in the conversion kit.*

#### 1. Tasks to do first:

- Regulation of the inside pilot **-Pe-**. The regulator screw is under the plastic cap. Starting at the “completely closed (-)” position, make five complete anti-clockwise turns **-V1-** using a flat tipped screw driver.
- Quick partial opening regulation **-Vstart-**. The regulator screw is under the plastic cap. Starting at the “completely closed (-)” position, make a complete anti-clockwise turn **-Vstart-** using the cap itself.



### CAUTION

- *Do not use a screwdriver to make a quick partial opening regulation **-Vstart-**.*
- *Never move the screw resealed in red.*

#### 2. Regulating the GV1 valve with a heat stage operating.

- Adjust the main regulator (reading pressure Pa).
- Adjust the gas stage regulation fly wheel **-Vmax-**. To do so, loosen the first cylindrical head screw **-T-** next to the symbol -.
- Check the pressure reading in the manifold valve outlet **-Pc-**.

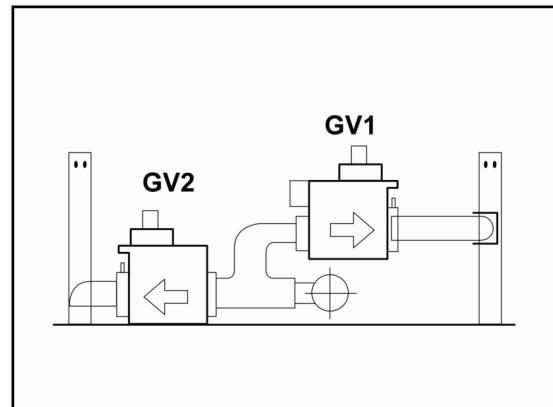

– Once adjusted, tighten the screw -T-.



**CAUTION**

*Never move the resealed blue screw next to the (+) symbol.*

3. Regulating the GV2 valve with two heat stages operating.

– Adjust the main regulator and the gas stage following the same procedures as described for valve GV1.

– After fifteen minutes of operation with the 2 heat stages, check the content of CO and CO<sub>2</sub>, according to *Post start-up checks*, see on page 19.

**Temperature rise regulation**

The temperature rise (or difference in temperature between the return air and the hot supply air) should be within the limits specified in the Installation Manual.

Once the temperature rise has been determined, the flow may be calculated as follows:

$$m^3/s = \frac{0,9 \times \text{kW gas input (*)}}{1,2072 \times \text{°C Temperature rise}}$$

(\*) Based on 90% rated output and on the net heating value of the gas.

Find the temperature rise after 15 minutes operating. So as not to be affected by radiant heat from the exchanger, the reading for hot air should be taken in the supply duct at a minimum of 2 metres from the unit connection.

**Increase** the air flow of the fan to **reduce** the temperature rise; **reduce** the air flow of the fan to **increase** the temperature rise.

**1.7 Unblocking the unit safely in case of breakdown**



**DANGER**

- *All side panels except for that of the electrical box, must be fitted, closed and secured with their corresponding locks before turning the general switch on the unit.*
- *The unit has a remote control, which means that the fan turbine may start unexpectedly.*

To unlock the unit, see "Restarting the HVAC unit in case of fault" in the User Manual.

If the thermostat display keeps showing the pilot light -1- and any fault code or if the HVAC unit does not start, contact a Johnson Controls Inc. Authorised Technical Assistance Service.

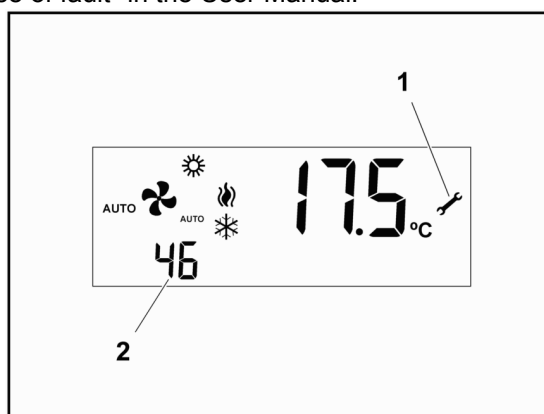

**1.8 Unit installation data**

Please complete the following data to register the full details of the installation and the start-up inspection.

Complete the blank fields or mark the appropriate box, as applicable.

### 1.8.1 List of tests for unit start-up

Please complete the following forms to register the full details of the installation and the start-up inspection.

Complete the blank fields or mark the appropriate box, as applicable.

<b>Company performing installation:</b>	
Installing technician:	
Name / project number:	
Location of the unit:	
Address of the unit location:	
Person in charge of the building or property where the unit is installed:	
Installation work start date:	
Unit model number:	
Unit serial number:	
Plate and version:	
Thermostat, model and version:	

<b>General inspection of the unit</b>	
	Visual appearance
	Levelling of the unit
	Check the unit for transport, loading and unloading damage
	Unit installed with sufficient clearance
	Check the circuit for the presence of oil (large coolant leaks).
	Terminals and connections correctly secured in the control panel and accessories
	Air filters installed
	Condensate drain pipe and drain trap installed correctly
	Thermostat and connection cabling installed correctly
	Air duct installation complete and correct
	Accessories and planned options installed (if applicable)

<b>Inspection of the air supply fan</b>	
	Drive belt and pulleys aligned and correctly fastened
	Drive belt tension correctly adjusted
	Verification of direction of rotation

Inspection of the gas heating section (models ARG/ARD)	
	Verification of the kind of gas supplied to the unit
	Combustion air input hood installed
	Exhaust hoods installed

Inspection of compressors	
	Verification that direction of rotation is correct

## 1.8.2 Start-up data

### Electrical data

	Rating plate	Actual
Power supply	Check specification in section <i>Technical and physical data for ARC (only cooling) and ARG (only cooling + gas heating)</i> , see on page 0 , or <i>ARH technical and physical data (heat pump) and ARD (heat pump + gas heating)</i> , see on page 0 .	
Control voltage		
Fan consumption (A)		
Consumption of condenser fan 1 (A)		
Consumption of condenser fan 2 (A)		
Consumption of compressor 1 (A)		
Consumption of compressor 2 (A)		
Consumption of supply fan (A)		
Heating element 1 (Optional)		
Heating element 2 (Optional)		

### Cool and heat modes

Cooling circuit. Compressor 1		
Mode	Value	
Subcooling (min. 8 K, max. 18 K)	°C	Liquid pressure: ____ bar
		Liquid temperature: ____ °C
Superheat (min. 4 K, max. 10 K)	°C	Suction pressure: ____ bar
		Suction temperature: ____ °C
	Complete liquid line checked in sight glass	
	Correct oil level checked in sight glass	

Cooling circuit. Compressor 2		
Mode	Value	
Subcooling (min. 8 K, max. 18 K)	°C	Liquid pressure: ____ bar
		Liquid temperature: ____ °C
Superheat (min. 4 K, max. 10 K)	°C	Suction pressure: ____ bar
		Suction temperature: ____ °C
	Complete liquid line checked in sight glass	
	Correct oil level checked in sight glass	

**Air flow rate values**

	m <sup>3</sup> /h
Design	
Measured	

**Air temperature**

Mode (cool or heat):	Temperature (°C)
Outdoor air:	
Supply air:	
Return air:	
Indoor air mix (if economiser is fitted):	

**OPTIONS****Heating mode (hot water coil)**

Air temperature	
Capacity: _____ (kW)	Temperature (°C)
Supply air (at 100 %)	
Return air	

Hydraulic circuit		
	Temperature (°C)	Pressure (bar)
Water inlet		
Water outlet		

**Heating mode (gas burner) (ARG/ARD models)**

Air temperature	
Capacity: _____ (kW)	Temperature (°C)
Supply air (at 100 %)	
Return air	

Gas circuit (Natural gas)			
Gas family		G20	Pressure (mbar)
		G25	
Supply line	Min 12,5 / Max 25 mbar		
Gas valve adjustments	Main regulator (PBr)		
	Stage regulator (V <sub>max</sub> )		
Gas consumption m <sub>3</sub> /h			

Propane gas conversion, G31, if applicable		
Supply line	37 mbar	Pressure mbar

Gas valve adjustments	Main regulator	
	Stage regulator	
	Gas consumption m <sub>3</sub> /h	

Combustion analyser
---------------------

Outdoor ambient temperature	
Smoke temperature	
Carbon monoxide content	

Combustion analyser	
Outdoor ambient temperature	___ °C
Smoke temperature	___ °C
Carbon monoxide CO content	___ ppm or ___ %
Carbon dioxide content CO <sub>2</sub>	___ %
Nitrogen oxide content NO	___ ppm

**Others**

Outdoor fan 1	Type or model	
		Surge protection adjusted

Outdoor fan 2	Type or model	
		Surge protection adjusted

Indoor fan	Type or model	
		Surge protection adjusted

Belts	Type or model	
Economiser		Minimum outdoor air setting

