

## Installation instructions



Clima Roca York S.L. is participating in the EUROVENT Certification Programme. Products are as listed in the EUROVENT Directory of Certified Products, in the program AC1, AC2 and AC3.



	<b>Page</b>		<b>Page</b>
<b>Installation instructions</b>	<b>5</b>		
- General	5	- Operating at -15°C	14
- Protection of the environment	5	- Operating with emergency heat	14
- Warning signs	5	- Other safety features of the electric circuit	14
- Transport	5	- Compressor sump heater	14
- Location	5	- Module	15
- Clearances	6	- Detail module internal connections to the connector	15
- Fastening the unit (Standing on the ground)	6	- Processes initiated by state of the probes	15
- Air ducting	6	- Led self-diagnosis indications	16
- Orientation of the air intake and discharge	6	- Functions of the bridges (pins)	16
- Charges to be made at the jobsite	6	- Before finalising the installation	16
- Drainage connections	6		
- Procedure for discharge transformation from horizontal to vertical	7 - 8	<b>Operating instructions</b>	<b>17</b>
- Compact installation of the units	9	- General introduction	17
- Installation of separated units	9	- Important warnings	17
		- Recommendations for better functioning	17
		- Start up	17
<b>Electrical installation</b>	<b>10</b>	- Ambient thermostat units of 1 & 2 circuits	17
- Electrical characteristics	11	- Operation and start up	18
- Limits of use	11	- Internal configuration of the thermostat (units 2 circuits)	20
- Adjustment of the balance point	11	- Graphic information	20
- Logic module	11		
- "Exterior" sensor	12	<b>Maintenance</b>	<b>21</b>
- "Discharge" sensor	12	- Indoor unit outflow ducts	21
- "Liquid" sensor	12	- Cleaning the filters	21
- Balance point	12	- Cleaning the outdoor	21
- Timer	12	- Priming the drainage siphon	21
- Switching off indoor fan during defrost	12	- Checking drive belt tension	21
- Switch-off delay of the indoor fan	12	- Access to the units for maintenance servicing	21
- Miscellaneous	12		
<b>Operation</b>	<b>12</b>		
- Summer cycle	12	<b>General dimensions</b>	<b>22 - 26</b>
- Winter cycle	12		
- Operating sequences	12	<b>Wiring diagrams</b>	<b>27 - 46</b>
- Defrost cycle (timed)	14		



# Installation instructions

## General

The BCVO/I model heat pumps are supplied in standard form as separate units. They are designed for installation with ducking on terraces, roof-tops, in lofts or basements.

When necessary, and at the moment of installation, they can easily be joined together, forming a compact item of equipment, except for the combination BCVO-80/CHI-800 which should always be installed as split units.

Control for starting, stopping and temperature regulation is with a special 24-volt thermostat delivered in the outdoor unit of each set of equipment.

## Protection of the environment



### Packing

Packing is made of recyclable material. The disposal of same should be carried out in accordance with the regulations on selective residue disposal established by the local authorities.

### Disposal of the unit

When dismantling after a long service life, its components should be ecologically salvaged. The cooling circuit is full of HCFC-22 refrigerant which should be salvaged and, finally, returned to the gas manufacturer for recycling.

Oil will remain in the airtight compressor so, it will be returned along with the sealed circuit.

The air conditioning unit will be deposited wherever established by the local authorities for its selective disposal.

## Warning signs

The following signs indicate the presence of potentially dangerous conditions for the users or service personnel. Whenever found on the unit itself, keep in mind the warning indicated by each one.

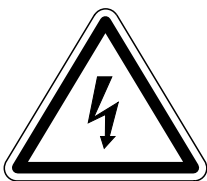

This sign indicates an electrical risk or danger.



Attention: The unit has a remote control system and can start automatically. Two minutes prior to having access to the interior, the power supply should be disconnected so as to avoid any contact with the fan turbine in operation.



Attention: It is compulsory to read the instructions prior to any handling.



Attention: Not to touch the hot surfaces.



Attention: Wheel and belt transmission.

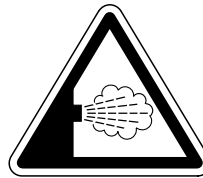

Attention: Possible escape of gas if incorrectly handled.

## Transport

The outdoor units must be transported in a vertical position so that the oil does not come out of the compressor. If it is necessary, for some reason, to alter this position from time to time, it should be returned to the vertical position as soon as possible.

## Location

The location should be chosen to provide for access for maintenance at all times, through both the lateral and rear panels.

The exterior unit can be installed directly out of doors. If it is installed indoors, in basements, lofts, etc., air ducts for introducing air from outside and extraction must be connected.

With indoor installations it must be remembered that, in the winter operating cycle, the outdoor coil condenses a lot of water which has to be eliminated through the drainage tube. Provision should be made for the possibility of obstruction of the drain by foreign bodies such as dust, dirt, etc.

### Clearances

Clearances should be left in the installation of each apparatus for:

- a) Intake and discharge of air from the outdoor unit.
- b) Connection of the drainage and electrical tubes.
- c) Air ducts.
- d) Maintenance service.
- e) Electrical wiring.
- f) Cleaning the filters.

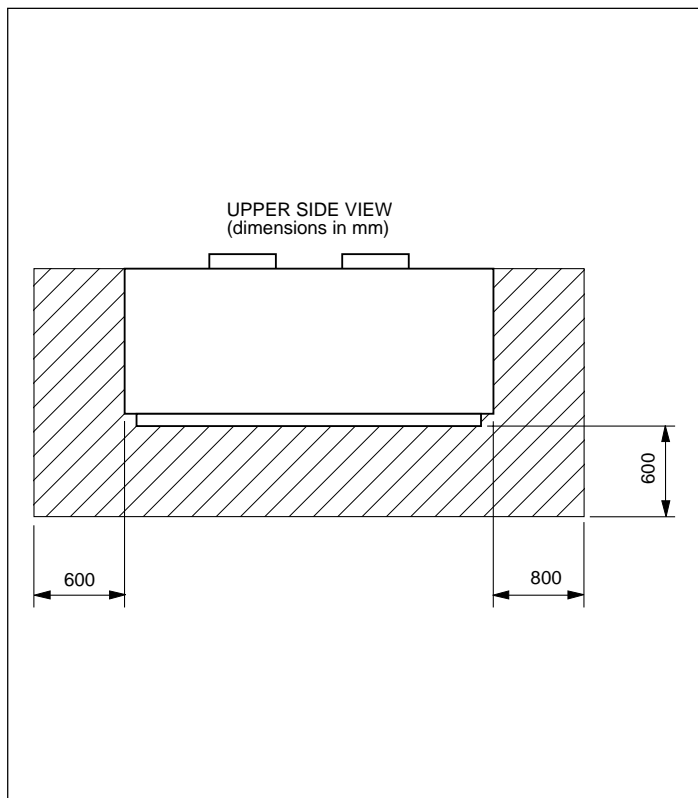

### Fastening the unit (Standing on the ground)

If the unit is stood out doors on the ground, it should be raised up on supports to avoid any possibility of snow obstructing the air intake.

### Air ducting

- 1.- Connect the ducting, insulating it from the apparatus with a flexible complying, preferably of non-combustible material, so as to prevent transmission of vibration from the apparatus itself. If the ducts are made of flexible material the vibration will not be transmitted.
- 2.- It is advisable to put a damper on each section of the ducting to maintain a correct balance in the system.
- 3.- Provide easy access for cleaning and changing the air filters.
- 4.- With the BCVO-45 & 60 units, two independent ducts should be installed, one for each fan to the discharge, so as to avoid recirculation of air.
- 5.- If the air discharge of the outdoor coil is done through ducts, it is advisable that the first meter section be of galvanized sheet to avoid corrosion produced by water droplets carried by the air.

### Orientation of the air intake and discharge

The standard orientations for air intake and discharge are as shown in the drawing.

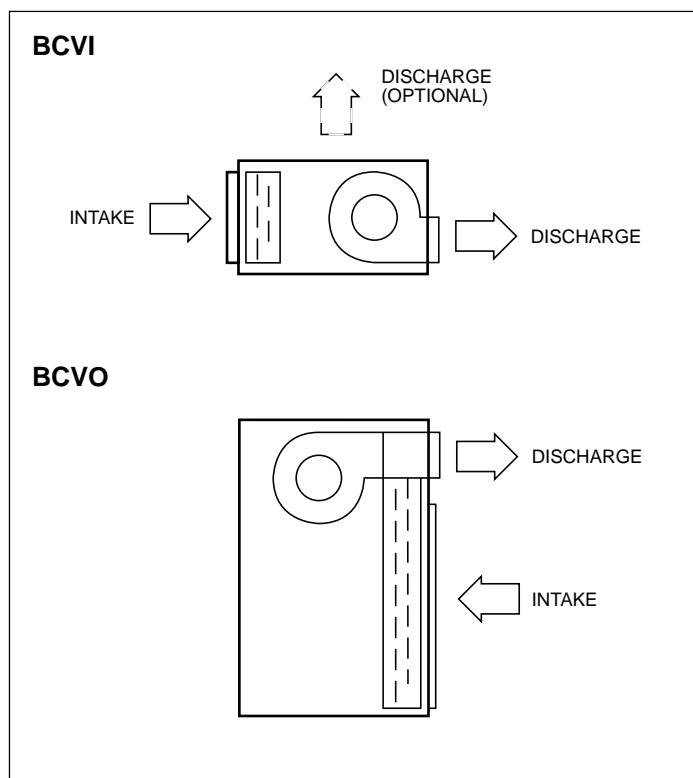

### Changes to be made at the jobsite

If required, the apparatus can easily be modified at the jobsite to give a vertical discharge from the indoor fan (BCVI).

### Drainage connections

Install the drainage tubes for each drain-pan through a trap. Leave a minimum level difference of 75 mm between the height of the connection to the apparatus and the line after the trap (see drawing). This is to avoid the depression produced by the fan, from interfering with the emptying of the pan. Access should be provided so that the trap can be filled with water at the beginning of each season. The drainage line should have a minimum slope of 2 cm per metre of length. The connections for the apparatus are of steel tubing with 3/4" G. interior thread.

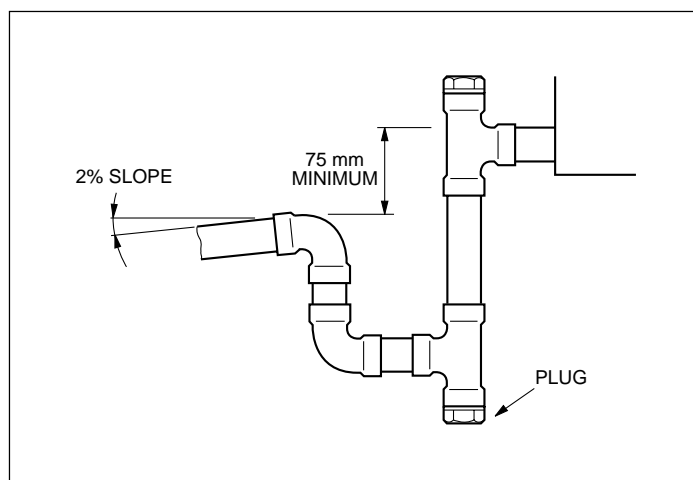

### Attention:

When the heat pump operates at outdoor temperatures of less than 5°C, the drainage tubes may be obstructed by ice.

To deal with this possibility it is convenient to install an electric heater in the drainage connection and around the anti-vibration elements of the compressor, connecting it electrically as indicated in the diagrams provided.

**Procedure for discharge transformation from horizontal to vertical**  
**(BCVI-20, 25, 30, 40, 45)**

- 1.- Remove the attachment screws from the side panels 1 & 2 of the upper unit.
- 2.- Take off side panels 1 & 2.

**Standard orientation**

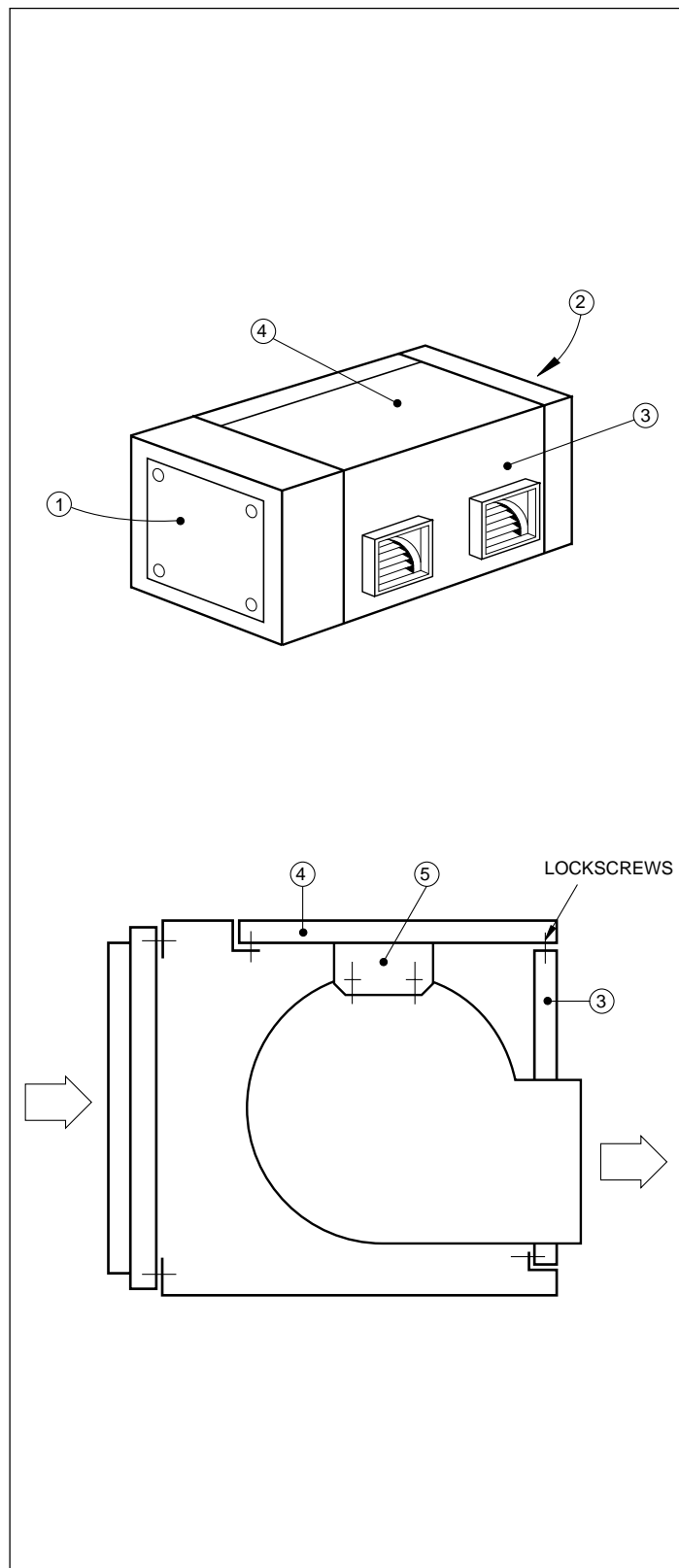

- 3.- Loosen the screws attaching the fan motor to its base, and remove the transmission belt.
- 4.- Through the side accesses, unscrew the panels 3 & 4, as shown in the standard orientation drawing.
- 5.- Unscrew the attachment of the fan to support 5.
- 6.- Place panel 3 where panel 4 was previously, and panel 4 where 3 was.
- 7.- Screw home the panels and the fan to support 5.
- 8.- Replace the transmission belt and attach the motor to its base.
- 9.- Screw on the lateral panels 1 & 2.

**Orientation variant at the jobsite**

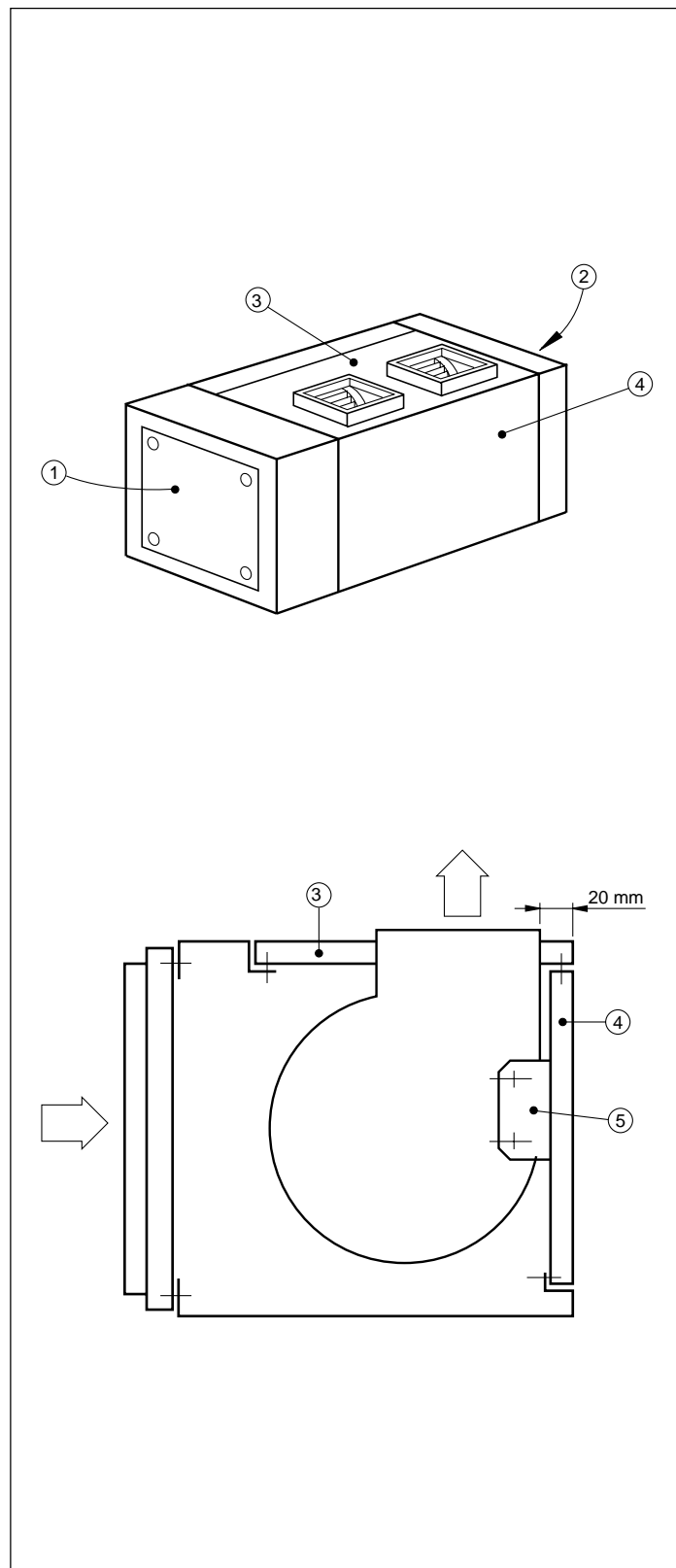

### BCVI-60 Unit

The BCVI-60 needs a transformation kit which includes: rear and upper panel, belts, motor and fan pulleys.

- 1.- Remove the standard upper, rear and side panels and the fans, and orient them as shown in the drawing, attaching them to the upper panel included in the transformation kit.

- 2.- Once the fans are installed, attach the upper panel Ref. 1 to the unit.
- 3.- Attach the left and right fan brackets, Ref. 3, to the unit.
- 4.- Install the motor pulleys, fan and belts, Ref. 2, included in the kit.
- 5.- Install the rear panel, Ref. 4.
- 6.- Finally, install the standard side panels.

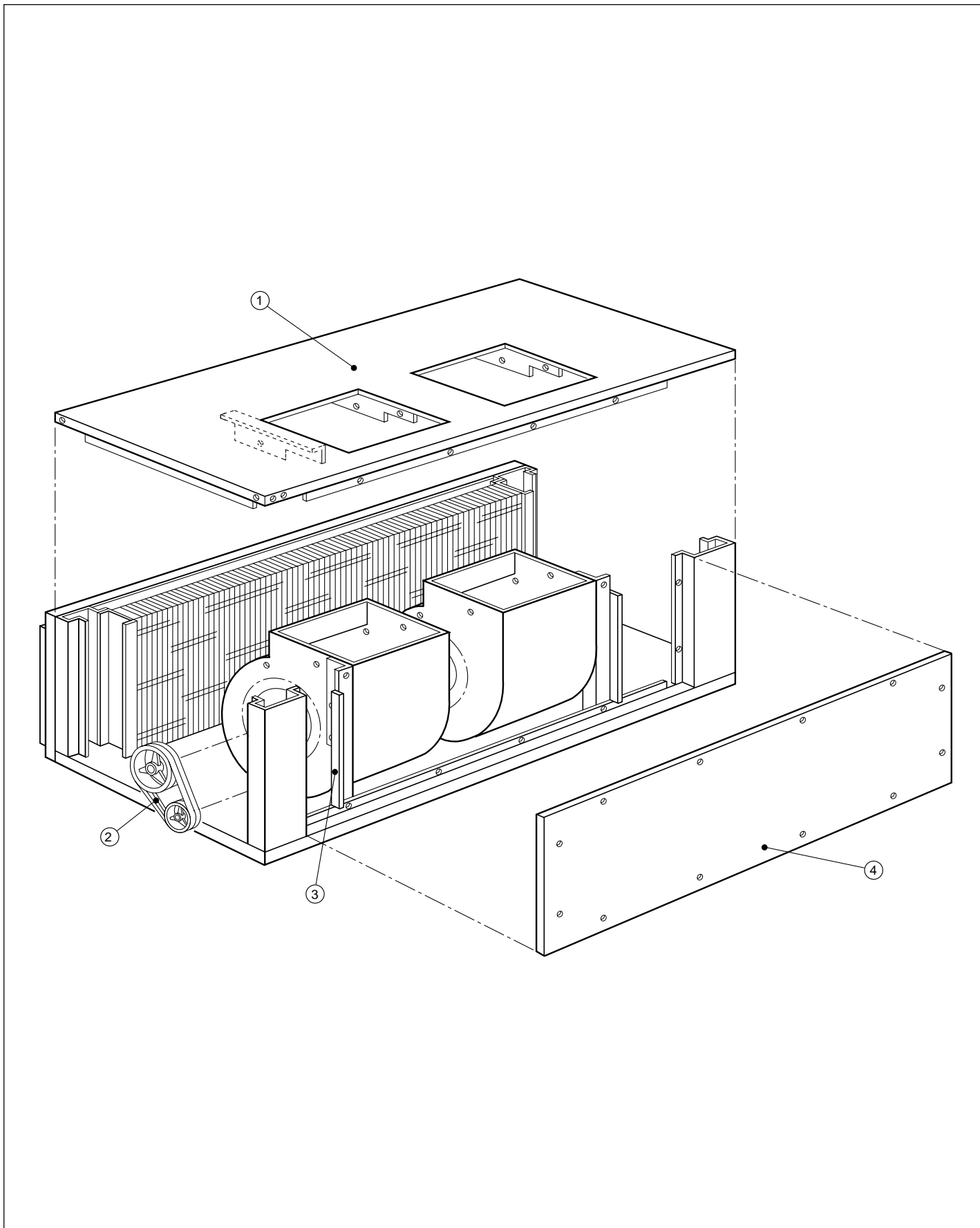

## Compact installation of the units

The units are supplied prepared for cooling and electrical connections.

To install the heat pumps as a compact unit, the outdoor BCVO and indoor BCVI units must be joined by using the holes in each unit and the screws supplied in a bag in the electrical box in the case of BCVO/I-60 and inside the indoor units of BCVI-20/25, 30/40 & 45.

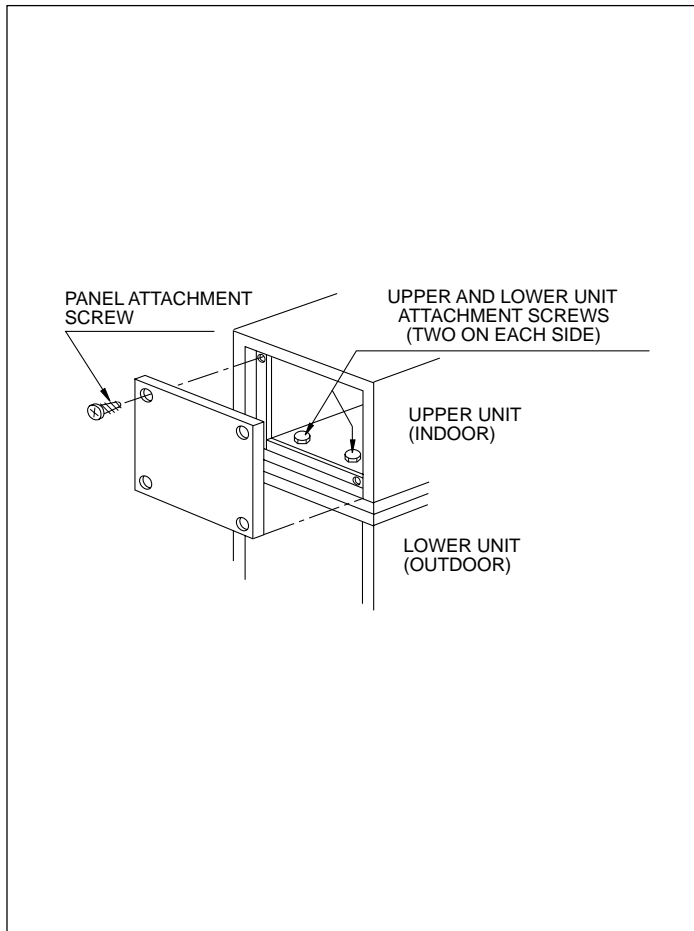

The BCVO and BCVI units are supplied with the refrigerant circuit connections ready for welding, and to be interconnected on the outside of the casing.

The BCVO/I-20, 25, 30 and 40 have only one circuit. The BCV-45, 60 and 80 units have two circuits. The refrigerant load should be carried out at the jobsite.

### Charge procedure

- 1.- De-pressurise the units.
- 2.- Drain the refrigerant.
- 3.- Clean out with dry nitrogen.
- 4.- Solder the tubes, with a dry nitrogen flow inside the tubes.
- 5.- Use low melting-point rods with a minimum silver content of 5% for soldering.
- 6.- Fill with 2 kg R-22 refrigerant to detect leaks.
- 7.- Empty out the refrigerant.
- 8.- Clean out with dry nitrogen.
- 9.- Create a vacuum down to 200 microns.
- 10.- Put in the refrigerant, using scales or a calibrated cylinder. The charge accuracy should be of 30 grams.

The outdoor unit is fitted with pressure and temperature points on the connection outlets, for checking of over-heating and sub-cooling. Check that these values are around 5°C.

## Installation of separated units

### Separation between the units

The length of interconnection tubing should be kept to a minimum.

### Standard installation

The maximum admissible distances with the standard circuit and tube diameters are:

Total length of tubing m	Maximum level difference between units m
20	10

### Special installation

For greater lengths, the installation must be made with a project previously approved by our technical service.

Modifications to any of the following may be required for such a project:

- Tube dimensions.
- Refrigerant charge.
- Suction traps.
- Suction accumulator.
- Liquid solenoid valve.

In such cases, the maximum lengths which can be recommended are:

Type of installation	m	
Units at same level, maximum length.	m	50
Outdoor unit higher than indoor, maximum length and level difference.	m	50
Outdoor unit lower than indoor, maximum length and level difference.	m	15

### Cooling interconnections

When preparing the tubing to join the two units, special care should be taken to keep it clean and dry before the installation. The following recommendations serve as a guide which should be taken into consideration:

- 1.- Use only copper tubing of cooling quality.
- 2.- Do not carry out outdoor jobs in the rain.
- 3.- The ends of the tubes should be kept closed off during the installation.
- 4.- Do not leave the dryer filters or the compressor open to the elements for more than one or two minutes.
- 5.- For soldering, use low melting-point rods with a minimum silver content of 5%.
- 6.- During soldering, and for as long as the tube stays hot, keep up a flow of dry nitrogen to avoid formation of oxides and crusting in the interior, which could cause contamination and blockage.
- 7.- Do not use stripper for copper-copper unions.

## Interconnection tubing diameters

Model	Diameter gas line (wide tube)	Diameter liquid line (narrow tube)
<b>BCVO/I-20, 25 &amp; 45</b>	1 1/8" (28.5 mm)	1/2" (12.7 mm)
<b>BCVO/I-30, 40 &amp; 60 &amp; BCVO-80/CHI-800</b>		5/8" (15.87 mm)

## Refrigerant charge

The nominal charge shown in the table below is calculated for the functioning of a compact unit.

When a split system is installed, the refrigerant charge must be increased in each circuit in function of the length of liquid tubing.

Model	Nominal charge R-22 kg	Number of circuits	Diameter liquid line	Additional charge (per metre)
<b>BCVO/I-20</b>	10	1	1/2"(12.7mm)	104 grs.
<b>BCVO/I-25</b>	10.9	1	1/2"(12.7mm)	104 grs.
<b>BCVO/I-30</b>	15.9	1	5/8"(15.87mm)	170 grs.
<b>BCVO/I-40</b>	18.5	1	5/8"(15.87mm)	170 grs.
<b>BCVO/I-45</b>	9.9 x 2	2	1/2"(12.7mm)	104 grs.
<b>BCVO/I-60</b>	9 x 2	2	5/8"(15.87mm)	170 grs.
<b>BCVO-80/ /CHI-800</b>	9 x 2	2	5/8"(15.87mm)	170 grs.

## Charge procedure

- 1.- De-pressurise the units.
- 2.- Drain the refrigerant.
- 3.- Clean out with dry nitrogen.
- 4.- Solder the tubes, with a dry nitrogen flow inside the tubes.
- 5.- Use low melting-point rods with a minimum silver content of 5% for soldering.
- 6.- Fill with 2 kg R-22 refrigerant to detect leaks.
- 7.- Empty out the refrigerant.
- 8.- Clean out with dry nitrogen.
- 9.- Create a vacuum down to 200 microns.
- 10.- Put in the refrigerant, using scales or a calibrated cylinder. The charge accuracy should be of 30 grams.

The outdoor unit is fitted with pressure and temperature points on the connection outlets, for checking of over-heating and sub-cooling. Check that these values are around 5°C.

## Insulation of tubes

The interconnection cooling tubing must be insulated.

The insulation requires specific characteristics: it must be

easy to install, hard-wearing, water and fire-proof, and have a minimum thickness of 12 mm.

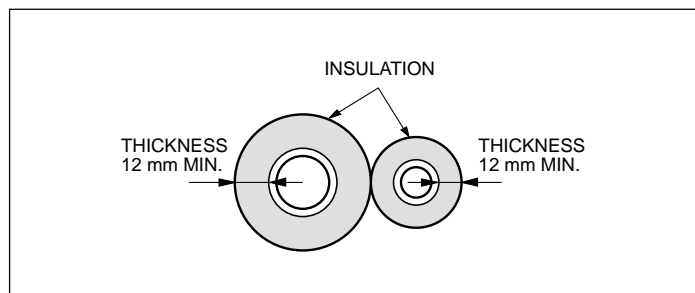

To avoid deterioration in sunlight, it is convenient to treat the insulation with enamel-water paint.

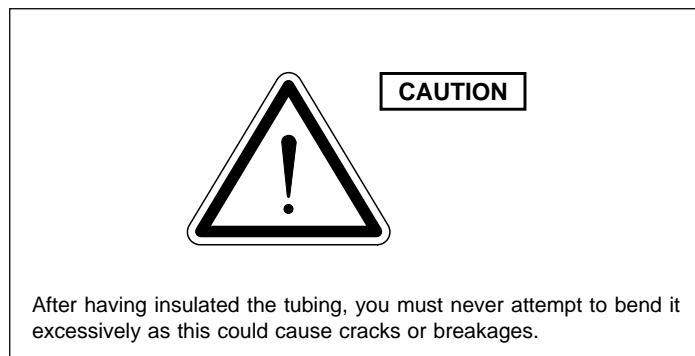

## Electrical installation

Each heat pump is delivered with a control box for connection to the power supply through a main switch with fuses or an automatic cut-out.

The electric heater, if there is one, must be installed with power line and switches independent of those supplying the conditioner.

In all cases, **established national regulations** must be observed.

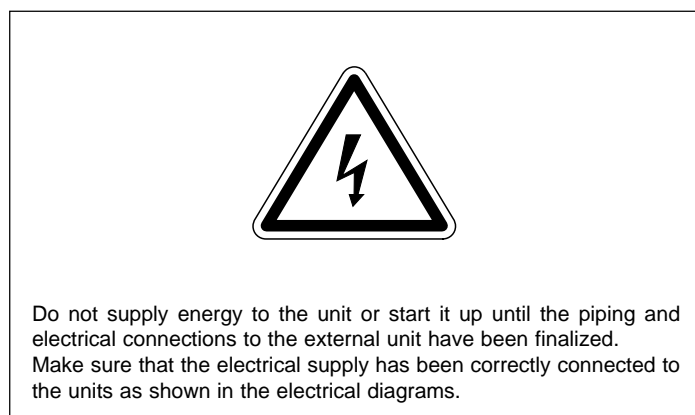
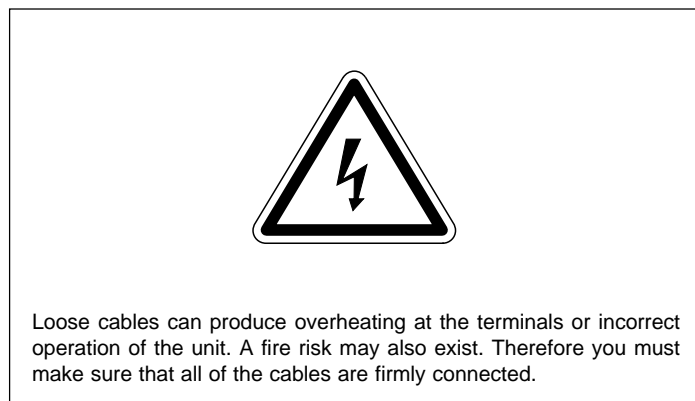

## Electrical characteristics

Model	Power supply V.ph.Hz.		Nominal consumption A							Power supply cables min.cross section mm <sup>2</sup>	Automatic circuit breaker A
	Compressor		Compressor			Indoor fan		Outdoor fan			
	Outdoor-Indoor		Start	Nominal	Max.	Start	Nominal	Start	Nominal		
<b>BCVO/I-20</b>	230.3.50	230.3.50	120	15	19.5	12	3.5	23	5.2	10	50
	400.3.50	400.3.50	60	8.5	11.3	7	2	10	3	4	32
<b>BCVO/I-25</b>	230.3.50	230.3.50	183	22.8	34.5	14	5.2	23	5.2	10	50
	400.3.50	400.3.50	90	13.2	20	7	2	10	3	4	32
<b>BCVO/I-30</b>	230.3.50	230.3.50	170	28.5	33	23	4.7	31	6.6	16	80
	400.3.50	400.3.50	100	16.5	19	10	2.7	25	3.8	10	50
<b>BCVO/I-40</b>	230.3.50	230.3.50	267	38.6	46	23	4.5	31	7	25	80
	400.3.50	400.3.50	135	22.3	27	10	2.6	25	4	10	50
<b>BCVO/I-45</b>	400.3.50	400.3.50	2 x 91	2 x 12.5	2 x 14.5	10	3.5	2 x 13	2 x 3	16	63
<b>BCVO/I-60</b>	400.3.50	400.3.50	2 x 100	2 x 16.5	2 x 19	25	7.1	2 x 18	2 x 7	25	100
<b>BCVO-80/CHI-800</b>	400.3.50	400.3.50	2 x 135	2 x 20.3	2 x 24	30	6.4	2 x 18	2 x 7	25/2.5	100/15

**Important:** The size of the circuit breaker and the cross-section of the supply and control lines are only as guide and should be corrected in accordance with the conditions at the jobsite, distance between units, and current legislation.

## Limits of use

Voltage limits				Outdoor coil inlet air temperature DB				Indoor coil inlet air temperature			
Nom. 230 V		Nom. 400 V		Operating cycle				Operating cycle			
Minimum	Maximum	Minimum	Maximum	Minimum °C		Maximum °C		Minimum °C		Maximum °C	
				Cool	Heat	Cool	Heat	Cool WB	Heat DB	Cool WB	Heat DB
198	254	342	436	19	-20 <sub>(1)</sub>	46	24	14	10 <sub>(2)</sub>	22	25

**Notes:** WB - Wet bulb. DB - Dry bulb.  
 (1) At an outdoor temperature of -20°C only the emergency electric heater (optional) continues to operate.  
 (2) The equipment can work for a short period at a temperature of less than 10°C in order to raise the air temperature in the conditioned space to 10°C.

## Adjustment of the balance point

The balance point is the lowest outdoor temperature at which the pump can heat up the building without additional electric heaters.

The balance point depends upon:

- 1) Outdoor design temperature.
- 2) Heat losses from the building.
- 3) Capacity of the pump.

The balance point is normally predetermined in the installa-

tion project. If it has not been predetermined, the factory regulation of 6°C can be left.

## Logic module

The logic module is the control centre for the heat pump.

It responds to the demand signals from the thermostat, examines the information from the "exterior", "discharge" and "liquid" sensors, determining whether the heat pump and/or the supplementary heater should function.

## "Exterior" sensor

This is a thermistor measuring the air temperature in the entry to the outdoor coil.

It controls the operation of the pump, stopping it when the outdoor temperature approaches -15°C. This prevents the compressor from operating at a high ratio, which could damage it.

It allows for the switching on of the duct heater (optional) controlled by the 2nd phase of the ambient thermostat, if the exterior temperature drops below -15°C.

Through the "balance point", it allows for adjustment of the temperature at which the additional electric heater has to be switched on.

## "Discharge" sensor

This is in the discharge tube from the compressor, installed in series with the high cut-out.

It protects the compressor against high operating temperatures.

It protects the compressor against high operating pressures. It stops the compressor if the discharge temperature exceeds what is permitted, or if the pressure exceeds 28 kg/cm<sup>2</sup>. It protects the compressor if there is a drop in refrigerant charge or a reduction in air flow-rate through the outdoor or indoor coils.

It permits resetting the compressor circuit after a lockout.

## "Liquid" sensor

This is in the liquid line of the outdoor coil.

It begins the defrosting cycle after a period of 30, 60 or 90 minutes (as selected) has elapsed from the start-up or since the previous defrosting, when the temperature detected drops to -5°C or less.

It stops the defrost cycle when the liquid temperature reaches 13°C or stays at a minimum of 7°C for at least 5 minutes.

It prevents defrost in mild climates when it does not detect a sufficiently low temperature.

The reading for the beginning of defrost of 30, 60 or 90 minutes is nominal. These periods are based on an outside temperature of 2°C, a highly unfavourable level which causes considerable frost formation.

At lower temperatures the overall humidity content of the ambient air is lower, making it possible to postpone the defrost cycles, thus saving energy. For example, at -10°C outside temperature, the reading times for the beginning of defrost will be 60, 90 & 120 minutes.

## Balance point

It prevents functioning of the support system when the outside temperature is higher than the balance point as adjusted on the plaque. In this way, we save the heater's functioning as long as the heat pump is capable of satisfying the building's requirements. The balance point can be adjusted between 14°C and -4°C. This avoids the necessity of fitting an additional outside thermostat.

## Timer

This delays the start-up for 5 or 2 minutes in order to prevent repeated starting cycles. It permits operating voltages to even up before the compressor starts. If the thermostat or manipulation lead to incorrect contacts, the heat pump is not affected. It delays starting up after a power cut, thus allowing the line voltage to return to normal levels.

## Switching off indoor fan during defrost (for units with a single compressor)

This module provides the option of stopping the indoor fan during the defrost cycle. The option is only for cases where it is not possible to fit an auxiliary electric heater.

- With the JP-19 bridge in place (as sent out from the factory) the indoor fan will continue operating during defrost.
- With the JP-19 bridge open (jobsite modification) the indoor fan is switched off.

## Switch-off delay of the indoor fan (for single compressor units)

The indoor fan will continue functioning for one minute more after the stop order.

This uses up the energy accumulated in the inside interchanger and saves energy.

This option can be deactivated at the jobsite, if preferred, by leaving the module JP-20 bridge open.

## Miscellaneous.

- Connector for computer switching.
- Possibility of lowering timer to 2 minutes.
- Buttons:
  - Test.** Lowers delay.
  - Reset.** Restarts the control.
  - Filters.** Delete dirty filter counter.
- Leds:
  - Standby.** Indicates compressor delay.
  - Filters.** Dirty filters.
  - Reset.** Self-diagnosis and reset Led.

## Operation

### Summer cycle

In summer operation, the 4-way valve is activated.

The circuit followed by the refrigerant is shown in the relevant diagram.

### Winter cycle

In the winter cycle, the discharge gas goes to the indoor coil, which acts as the condenser. The outdoor coil becomes the evaporator. The 4-way valve is not activated. The circuit followed by the refrigerant is shown in the relevant diagram.

## Operating sequences (See relevant wiring diagrams)

### Summer cycle:

Thermostat in COOL position

- 1) The 4-way valve is activated through the thermostat, permitting the refrigerant to circulate in the summer circuit.
- 2) If the fan operating mode in the ambient thermostat is in FAN ON, the contactor is activated and the fan functions continuously.
- 3) With the logic module timing, the unit will start up after 5 minutes.
- 4) When the thermostat contact connects, the contactor is activated and the compressor starts up. If the fan operating mode is in the normal position, the contactor is activated through the thermostat's cooling circuit and the fan starts up.
- 5) The unit will function intermittently in response to the

corresponding signal from the ambient thermostat to satisfy the cooling demand.

- 6) When the unit stops at the end of an operating cycle, or through a power failure, the logic module will not allow it to start up again until 5 minutes have elapsed. This is to protect the compressor by allowing the operating voltages to even up.
- 7) If the discharge pressure exceeds 28 kg/cm<sup>2</sup>, or the discharge temperature is over 130°C, the logic module will switch off the unit, leaving the system in lock-out.
- 8) To re-set after a lock-out, turn off the power supply to the unit. The system will re-set and the unit will start up after 5 minutes.

**Winter cycle:**

Thermostat in HEAT position

- 1) The 4-way valve is deactivated, allowing the position for the heating circuit, which means that the indoor coil acts as condenser and the outdoor one as evaporator.
- 2) If the fan operating mode in the ambient thermostat is in the FAN ON position, the contactor is activated and the fan functions continuously.
- 3) With the logic module timing, the unit will start up after 5 minutes.
- 4) When the first stage of the thermostat connects, the contactor is activated and the compressor starts up. If the operating mode of the fan is "normal", the contac-

tor is activated through the thermostat's heating circuit and the fan starts up.

- 5) The unit will function intermittently in response to the appropriate signals from the ambient thermostat to satisfy the demand for heating.
- 6) If the unit stops, after an operating cycle, or through a power failure, the logic module will not allow it to start up again until 5 minutes have elapsed. This is to protect the compressor by allowing the operating voltages to even up.
- 7) If the discharge pressure exceeds 28 kg/cm<sup>2</sup>, or the discharge pressure is over 130°C, the logic module will stop the unit, leaving the system in lockout.
- 8) To re-set after a lock-out, switch off the power to the unit. The system will re-set and the unit start up after 5 minutes.
- 9) The auxiliary heater is activated when the auxiliary heating stage of the thermostat is connected. The logic module allows the indoor auxiliary heater to function if the outdoor temperature is below the balance point. If the outdoor temperature is above that set as the balance point, the indoor heater does not function.
- 10) The emergency heater (complementary) is connected when the outdoor temperature is lower than that preselected as the operating limit (-15°C, logic module), and the ambient thermostat demands the second heating stage.

**Summer cycle diagram**

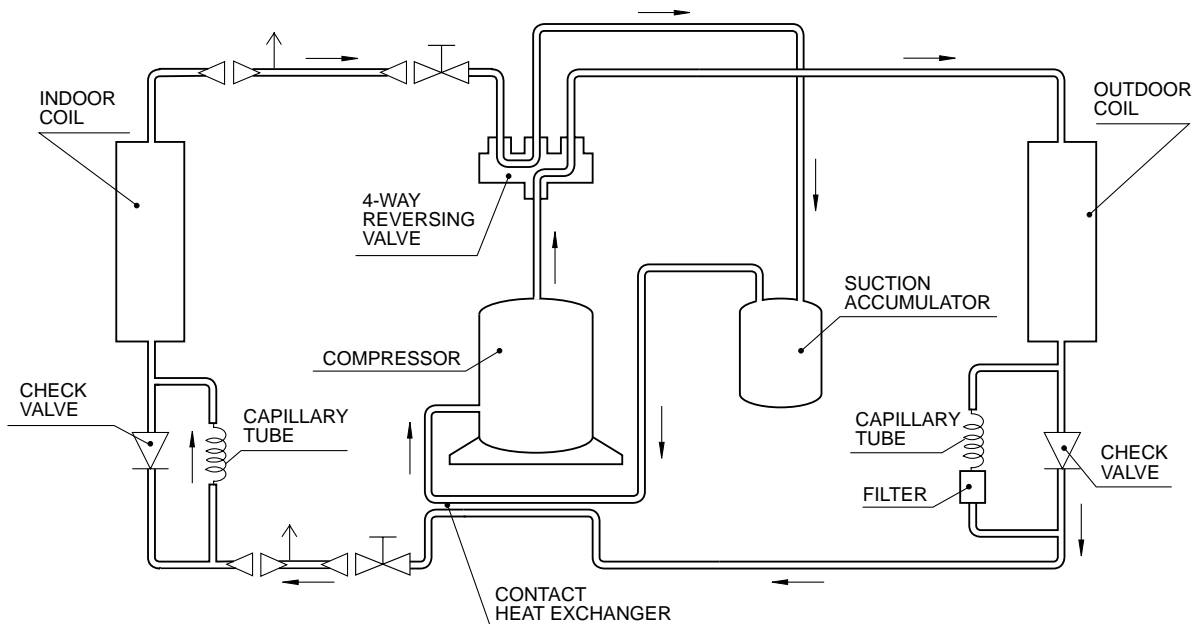

**Note:**

The BCVO/I-45 & 60 units have 2 independent circuits with similar characteristics. The diagram shows the circuit followed by the refrigerant in one of them.

## Winter cycle diagram

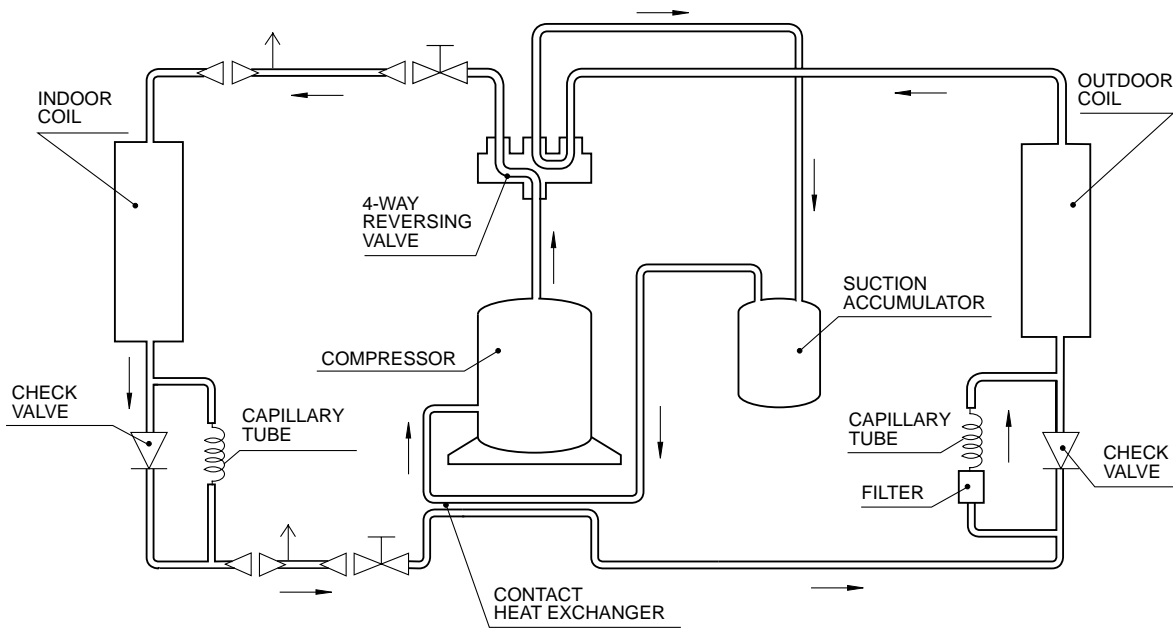

**Note:**

The BCVO/I-45 & 60 units have 2 independent circuits with similar characteristics. The diagram shows the circuit followed by the refrigerant in one of them.

## Defrost cycle (timed)

The ice which is produced on the outdoor coil during the heating cycle must be eliminated when it begins to block the coil.

The defrost cycle begins after a period selected between 30, 60 & 90 minutes from the start-up or the last defrosting, and when the evaporation temperature drops to  $-5^{\circ}\text{C}$  or less.

The logic module activates the defrost relay, which:

- Activates the 4-way valve to go into the cooling cycle.
- Switches off the outdoor fan.

The defrost cycle finishes when the liquid temperature is sufficiently high, measured by a thermistor  $13^{\circ}\text{C}$ , or when, if it does not heat up, it reaches a minimum of  $7^{\circ}\text{C}$  for a 5 minute period; also after 12 minutes from its beginning.

When the defrost cycle finishes, the logic module disconnects the defrost relay, reestablishing normal operating conditions of the heating cycle.

If the unit tries to go into another defrost cycle in less than 5 minutes, the logic module switches it off, leaving the system in lock-out.

## Operating at $-15^{\circ}\text{C}$ (optionally $-5$ , $-10$ , $-20$ )

When the outdoor temperature is less than  $-15^{\circ}\text{C}$  there is no justification for running the compressor with the limited amount of heat it generates.

If the logic module detects, through a thermistor in the exterior air entry, a temperature lower than  $-15^{\circ}\text{C}$ , it acts as follows:

- It disconnects the compressor.
- It switches on the emergency heater (if there is one installed) controlled by the thermostat's second stage. (The auxiliary heater will also continue to function, governed by the thermostat's second stage).
- It leaves the indoor fan functioning under the first heat-

ing stage of the thermostat.

## Operating with emergency heat

When the operating mode of the thermostat is in the emergency heat position (flashing HEAT signal on the display):

- The compressor will be in lock-out.
- The auxiliary and emergency heaters (if installed) will be governed by the first stage of the thermostat.

**Note:**

With the BCVI-45, the auxiliary heater is the indoor one and the emergency one is the second supplementary one in the ducting.

## Other safety features of the electric circuit

- The three-phase fans have manual re-set protection by thermal relay.
- The circuit is protected against failure of a phase. Re-setting is manual.
- The compressor is protected against overheating by a solid state protector with three sensors inside the windings. This also protects it against failure of a phase.
- The control circuit is protected by a fuse.
- A system of relays prevents the simultaneous function of the defrost system in both the BCVO/I-45 & 60 circuits.
- The casing and components, as a whole, are protected by an earthing circuit.

## Compressor sump heater

The compressor is fitted with a heater in the sump to prevent an excessive concentration of refrigerant in the compressor when it is switched off.

If the main switch has been turned off for some time, before starting up the heat pump the main must have been on again for at least 8 hours. This is to allow for refrigerant accumulated in the compressor to be eliminated.

# Module

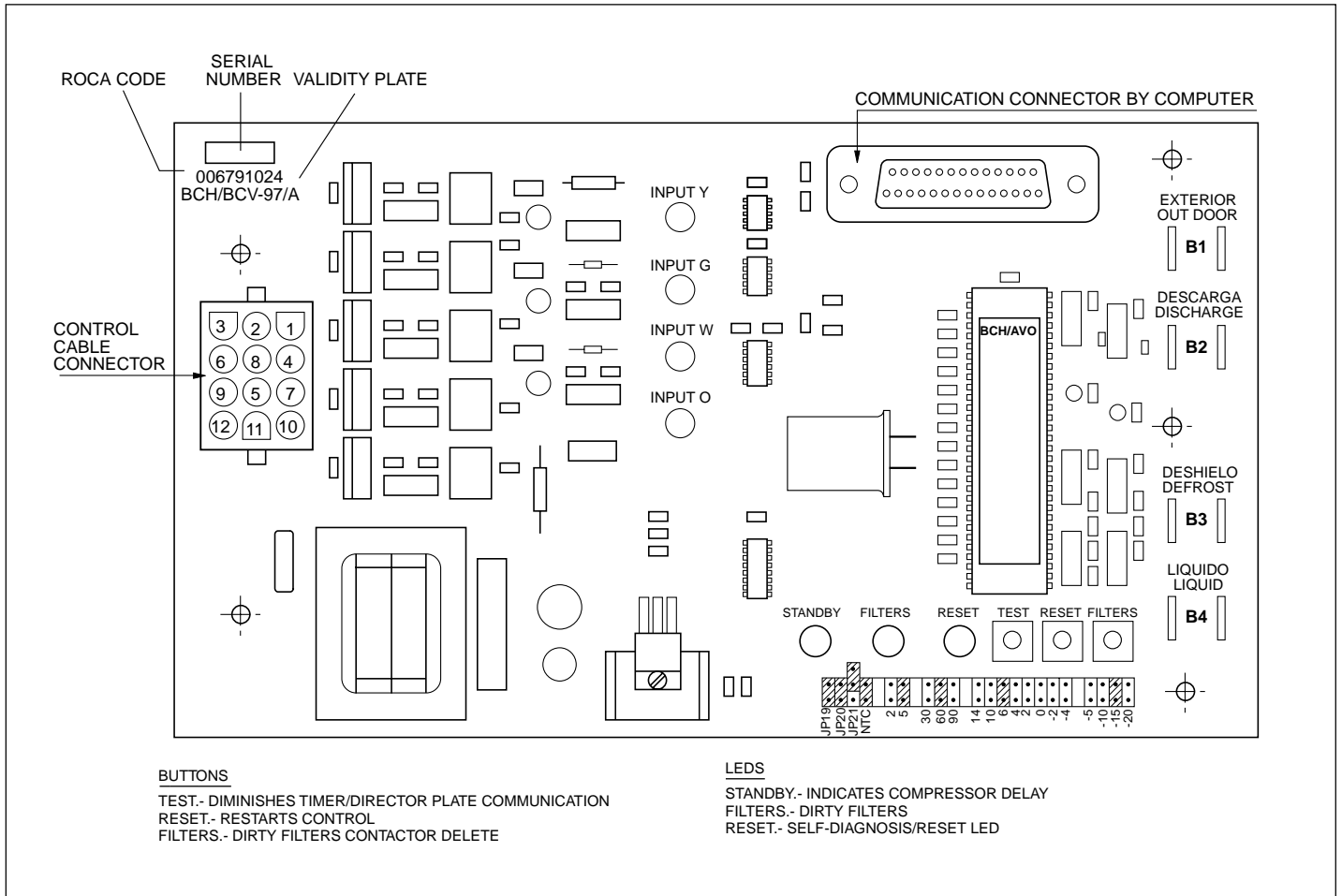

## Detail module internal connections to the connector

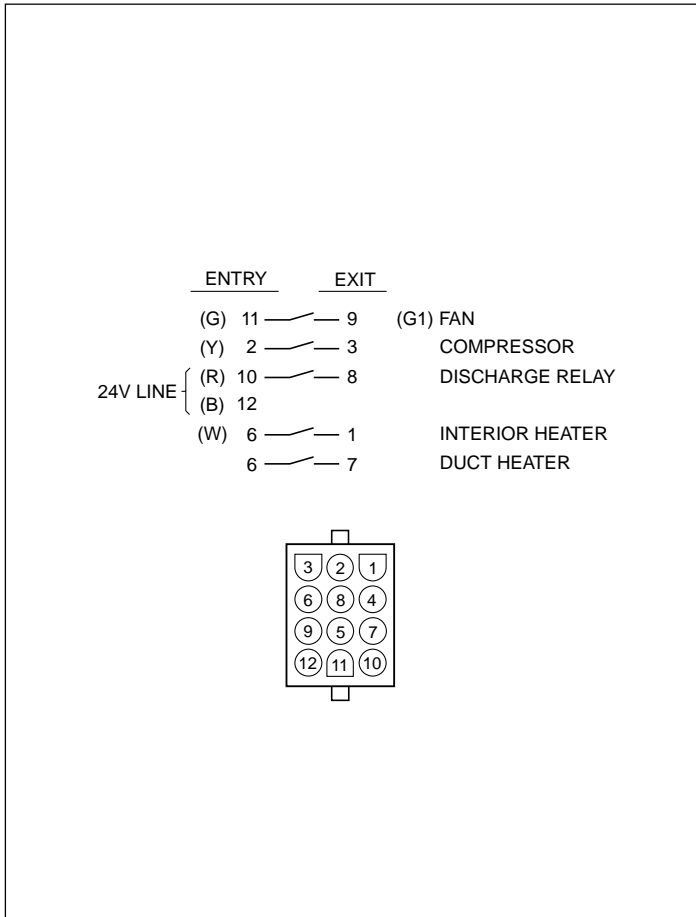

## Processes initiated by state of the probes

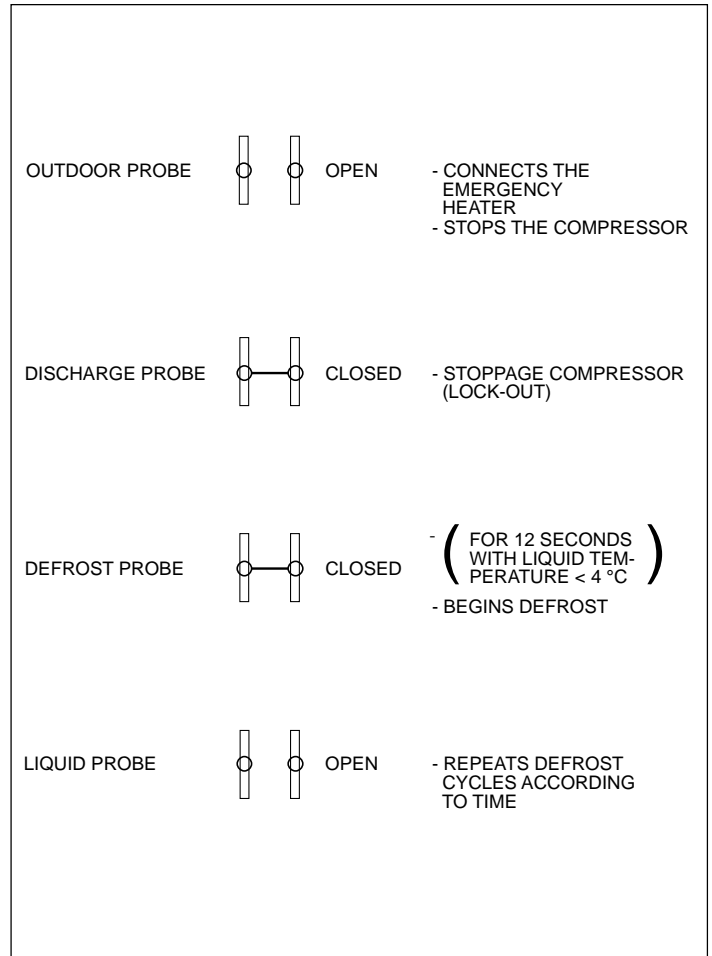

## Led self-diagnosis indications

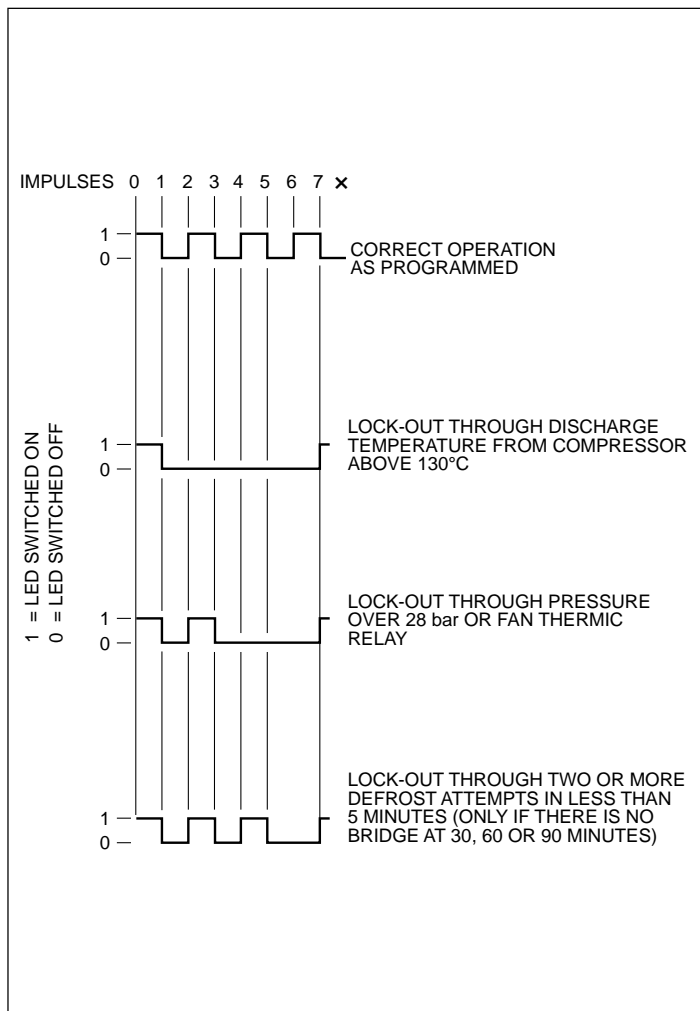

## Functions of the bridges (pins)

**JP19** NO / YES INDOOR FAN OPERATING DURING DEFROST

**JP20** NO / YES INDOOR FAN STOPS 1 MINUTE AFTER COMPRESSOR WITH DISCONNECTION TERMINAL G OF THERMOSTAT

**JP21** 130°C / 110°C LOCK-OUT DISCHARGE TEMPERATURE

- SCALE OF BALANCE POINTS: 14, 10, 6, 4, 2, 0, -2 & -4°C.
- START-UP DELAY TIME: 2', 5'.
- TIME BETWEEN 2 DEFROSTS: 60', 30', 90'.
- LOW TEMPERATURE DISCONNECTION SCALE: -5, -10, -15, -20°C.

THIS PLAQUE IS DELIVERED WITH 7 JUMPERS (PIN) IN:

CLOSING CIRCUIT: 5', 60', 6°C, -15°C, **JP19 & JP20**.  
WITHOUT CLOSING CIRCUIT: **JP21**.

## Before finalising the installation

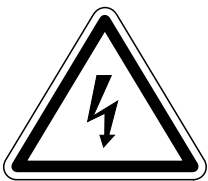

### Verify that:

- The voltage is always between 198-254 V or 342-436 V.
- The gauge of the supply cable is at least that which is recommended in the corresponding electrical diagrams.



- The need to clean the air filter has been communicated.



- The condensation drainage is perfectly assembled and there are no leaks in the water circuit.



- The guarantee split has been filled in.
- Maintenance instructions have been given or a contract has been made for periodic servicing.



- Instructions have been given to the users on how to operate the system.

# Operating instructions

## General introduction

The heat pump is an air to air type of equipment that provides air conditioning in summer and in winter by inverting its operation cycle.

The start and automatic temperature regulation are done by means of the 24 volt room thermostat specially designed for this units.

## Important warnings

The thermostat must be located on a wall which is not exposed to direct sunlight; should this not be the case, the temperatures would not be real and the operation of the heat pump would not be appropriate. Before start-up, turn on the main switch so that the electric heater in the compressor crankcase begins to operate.

**The compressor must not be started up until at least eight hours have passed.**



**CAUTION**

**ELECTRICAL SUPPLY**

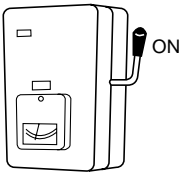

Connection:  
The electrical supply must be connected for at least 8 hours before operational start up of the conditioner in order to heat the system. Leave the supply connected, except when the conditioner is going to be out of use for long periods of time.

This is to allow the coolant which, in its liquid form, will have mixed with the compressor oil, to evaporate.

The heat pump is fitted with a safety device for the protection of the compressor which prevents it from being switched on again immediately after a shut down; five minutes must have elapsed between the shut down and the new start up.

## Recommendations for better functioning

- Turn the console on before the room gets hot. The heat accumulated on furniture, walls, etc. makes the console take longer to achieve the desired temperature.
- It is advisable to inspect and service your unit in the spring; this avoids damage and insures a long service of your console.

## Start up

After duly connecting the unit, taking into account the specifications outlined in the installation instructions manual for the heat pump, we can proceed to the start up, which is realised by means of the ambient thermostat.

## Ambient thermostat units of 1 & 2 circuits

This thermostat has been designed to proportion a precise control of the ambient temperature and to give graphic

### Controls and indicators

- 1.- Operational mode selection.
- 2.- Fan speed selection.
- 3.- Day/Night selection.
- 4.- Outdoor temperature reading option (units with 2 circuits)

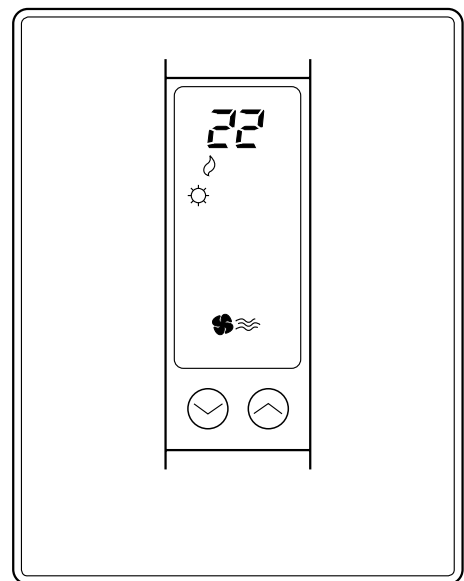
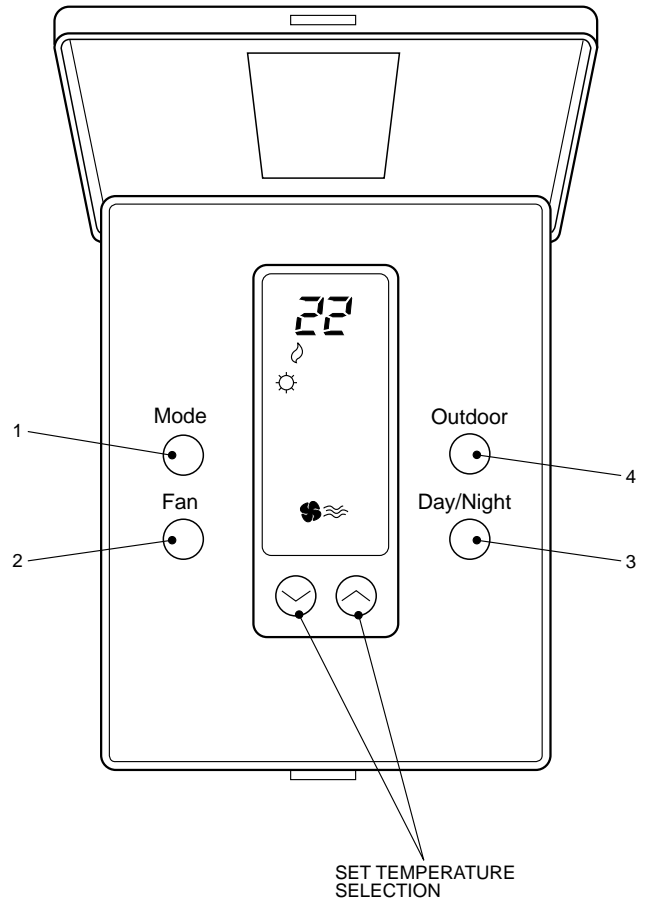

information of the mode in which the heat pump is operating. It is a control with a Proportional-Differential-Integral response which, in relation to the difference between the programmed and the ambient temperatures, varies the on/off cycles between 3 and 7.5 cycles per hour.

The liquid crystal display (LCD) normally indicates the ambient temperature, mode of operation, and whether the heating or cooling system is connected.

It allows the selection of different set points for heating and cooling, as well as the choice of °C or °F.

The operation of the fan can be set in continuous mode, or automatic, switching off and operating in unison with the compressor.

The controls are located underneath a cover which prevents their manipulation by unauthorised personnel.

## Operation and start up

Start up is implemented by the controls located on the thermostat.

### 1. MODE

The operational mode of the heat pump is selected by pressing this button. When the button is pressed the following operational modes appear on the liquid crystal display panel:

- COOL** ❄️ - Controls the system in the cooling mode. (The word **COOL** is displayed on the panel for 5 seconds).
- HEAT** 🔥 - Controls the system in the heating mode. (The word **HEAT** is displayed on the panel for 5 seconds).
- Auto** ❄️ 🔥 - Controls the system in cooling or heating according to requirements. (The word **Auto** is displayed on the panel for 5 seconds).
- E HE** - Controls the system in the emergency heating mode (it is only active if the optional accessory electrical resistance heater has been installed).
- OFF** - Disconnects the system.

#### a) Cooling

Press the MODE button repeatedly until the cooling symbol ❄️ is displayed on the panel (at the same time the word **COOL** is displayed for 5 seconds).

The cooling symbol continues to be displayed on the panel.

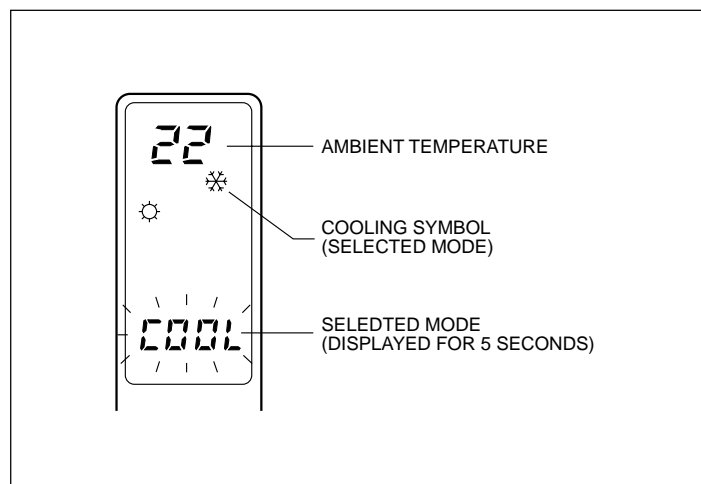

Once the operational mode has been selected, select the set temperature by pressing button ⬆️ or button ⬇️, whether this be to select a higher or a lower temperature. The set temperature is displayed accompanied by a small symbol which represents a thermometer, and remains visible on the display panel for 5 seconds. Once the set temperature will again be displayed.

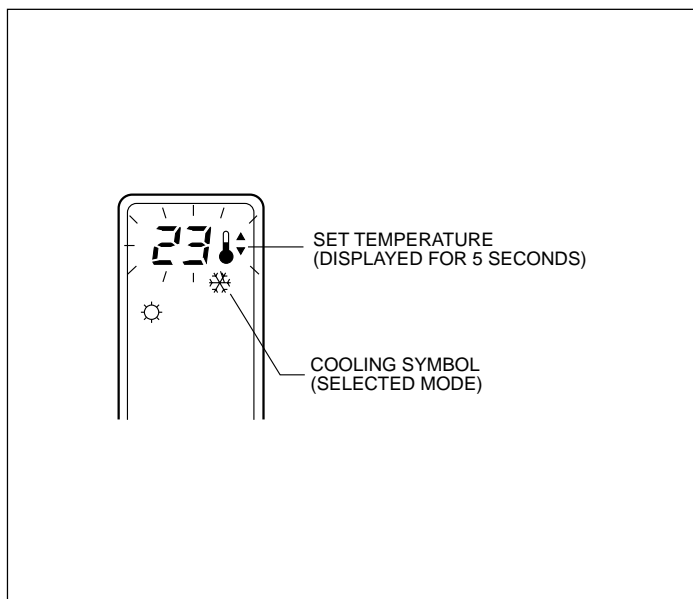

After a few minutes have passed the cooling system will start up, and the cooling symbol, visible on the display, will start to flash.

#### b) Heating

Press the MODE button repeatedly until the heating symbol 🔥 is displayed on the panel (at the same time the word **HEAT** is displayed for 5 seconds).

The heating symbol continues to be displayed on the panel.

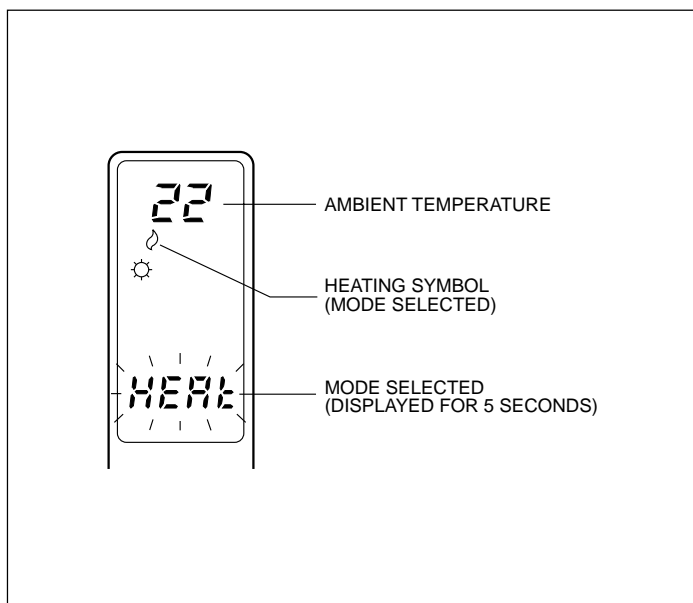

Once the operational mode has been selected, continue to select the set temperature by pressing button ⬆️ or button ⬇️, whether this be to select a higher or a lower temperature. The set temperature is displayed together with a small symbol which represents a thermometer, which is displayed on the panel for 5 seconds. After the set tem-

perature has disappeared then the ambient temperature will again be displayed.

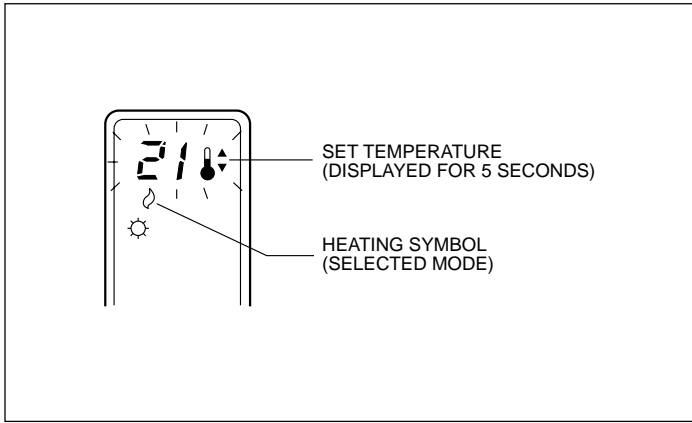

After a few minutes have passed the heating system will start up, and the heating symbol, visible on the display, will start to flash.

**c) Automatic**

Select a set temperature for the cooling mode and another for the heating mode, as described in paragraphs a and b. In this operational mode the set temperature for cooling **COOL** must be at least 1°C above the heating **HEAT** temperature, this is the minimum differential allowed by the thermostat. Press the MODE button repeatedly until the heating symbol and cooling symbol are displayed on the panel (at the same time the word **Auto** will be displayed for 5 seconds). The heating and cooling symbols will continue to be displayed on the panel.

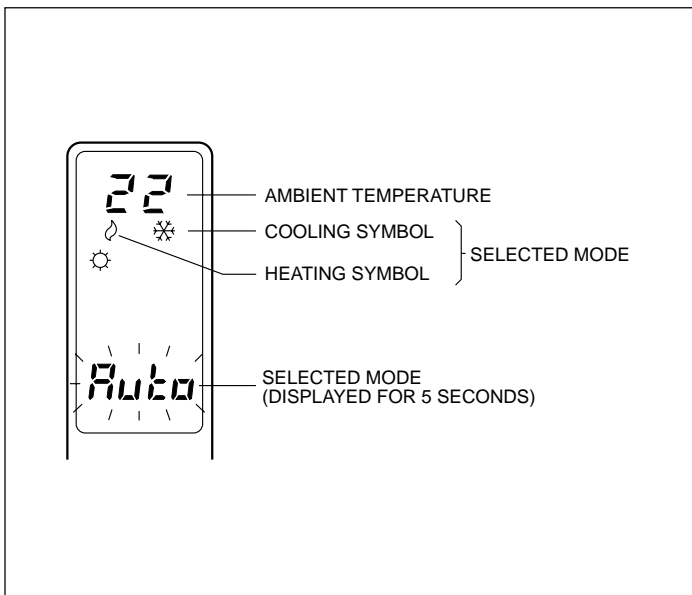

After a few minutes have passed the system will start up, automatically switching to the heating or cooling mode and maintaining the temperature between the selected margins. The symbol corresponding to the operational mode, heating or cooling, will start to flash.

**d) Emergency heating**

Repeatedly press the MODE button until the letters **E HE** (displayed for 5 seconds) appears on the display panel, at the same time the heating symbol will be displayed; once a few minutes have passed the emer-

gency heating will start up, and the heating symbol will start to flash.

In this operational mode the compressor is always shut down and the (optional) auxiliary and emergency resistance heaters, if they are fitted, are used to supply the heat. This operational mode can also be used for heating in case of a compressor breakdown.

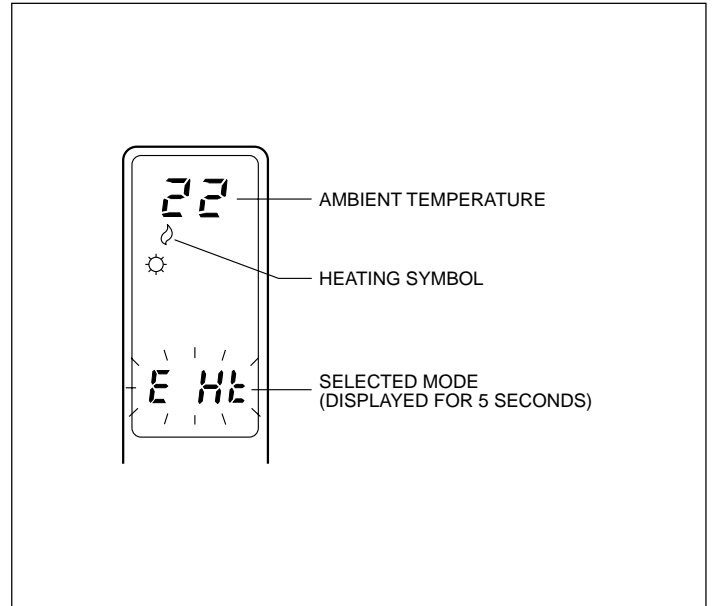

**e) Off**

Repeatedly press the MODE button until the word **OFF** appears on the display. The heat pump will stop and on the thermostat display panel the word **OFF** and the ambient temperature will be permanently displayed.

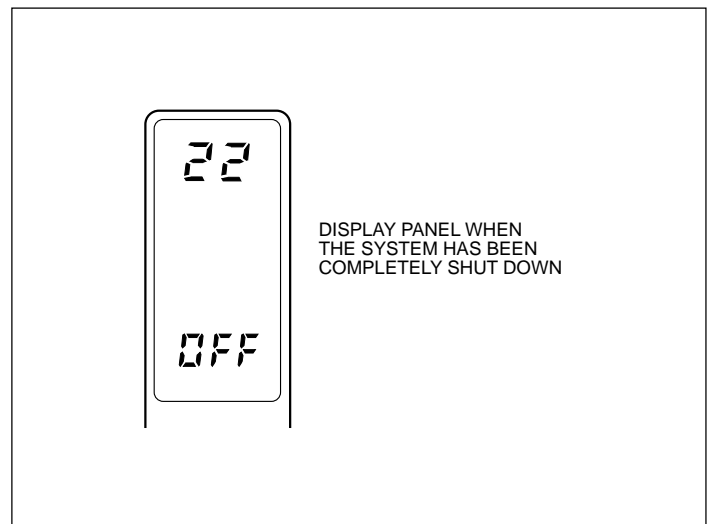

**f) °C / °F scale**

To change the scale of degrees of temperature, press the and buttons simultaneously.

**2.- Fan**

The Fan is started up in a continuous manner by pressing the FAN button (independently of the operational state of the unit), the fan and air-flow symbols will be displayed on the thermostat display panel, the fan symbol steadily and the flow symbol flashing.

The FAN symbol will disappear when the button is pressed again and the fan will be automatically controlled in

unison with the compressor or the electrical resistance heater (should this be installed).

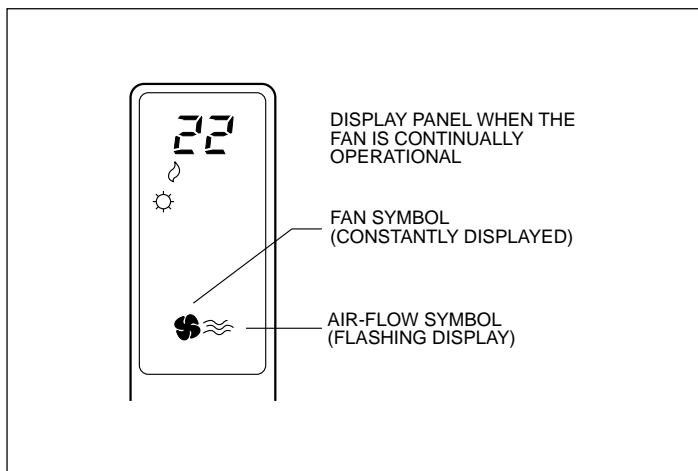

### 3.- Day/night selection

Different set temperatures can be selected by pressing the DAY/NIGHT button, for day and night (in each of the operational modes).

When installing the thermostat the ☀ symbol will be displayed, indicating that the temperature selected is set for the day. By pressing the DAY/NIGHT button the ☾ symbol is displayed on the panel, indicating that the temperature selected will be set for the night.

Every time that we press this button we alternate the established set temperatures, whether they be for the day ☀ or the night ☾.

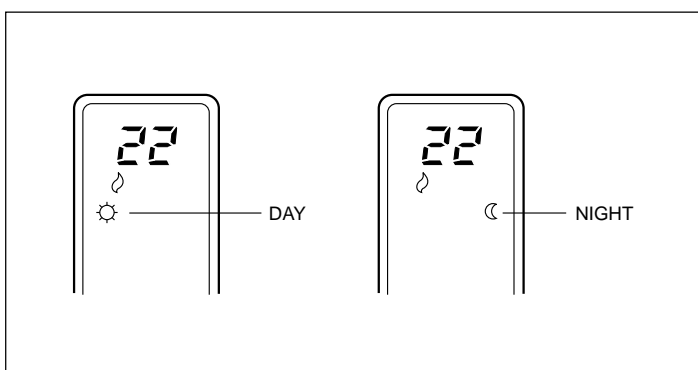

### 4.- Outdoor temperature reading option (units 2 circuits)

The thermostat allows for the option of installing a sensor for taking readings of the outdoor temperature. This temperature can be read off by pressing the OUTDOOR button.

### Remote ambient temperature sensor option (units 2 circuits)

The DSL thermostat has been designed to accept a remote sensor which allows for control of the ambient temperature for premises separated from the room where the DSL thermostat is installed. The remote sensor is connected to the RS1 - RS2 - RS + V, terminal strip inside the thermostat.

### LED 1 option (units 2 circuits)

The thermostat has an LED which if it is supplied at 24 V (through an exterior timer or pressure switch signal) can warn of the need to clean the filters.

### LED 2 option (units 2 circuits)

The thermostat has a second LED which, if supplied at 24 V, can be used as a service call.

## Internal configuration of the thermostat (units 2 circuits)

The thermostat has a configuration system (option) by means of micro-switches located on the base board.

The standard configuration of the thermostat must be that which is described in the following section.

### Adjustment of the micro-switches (units 2 circuits)

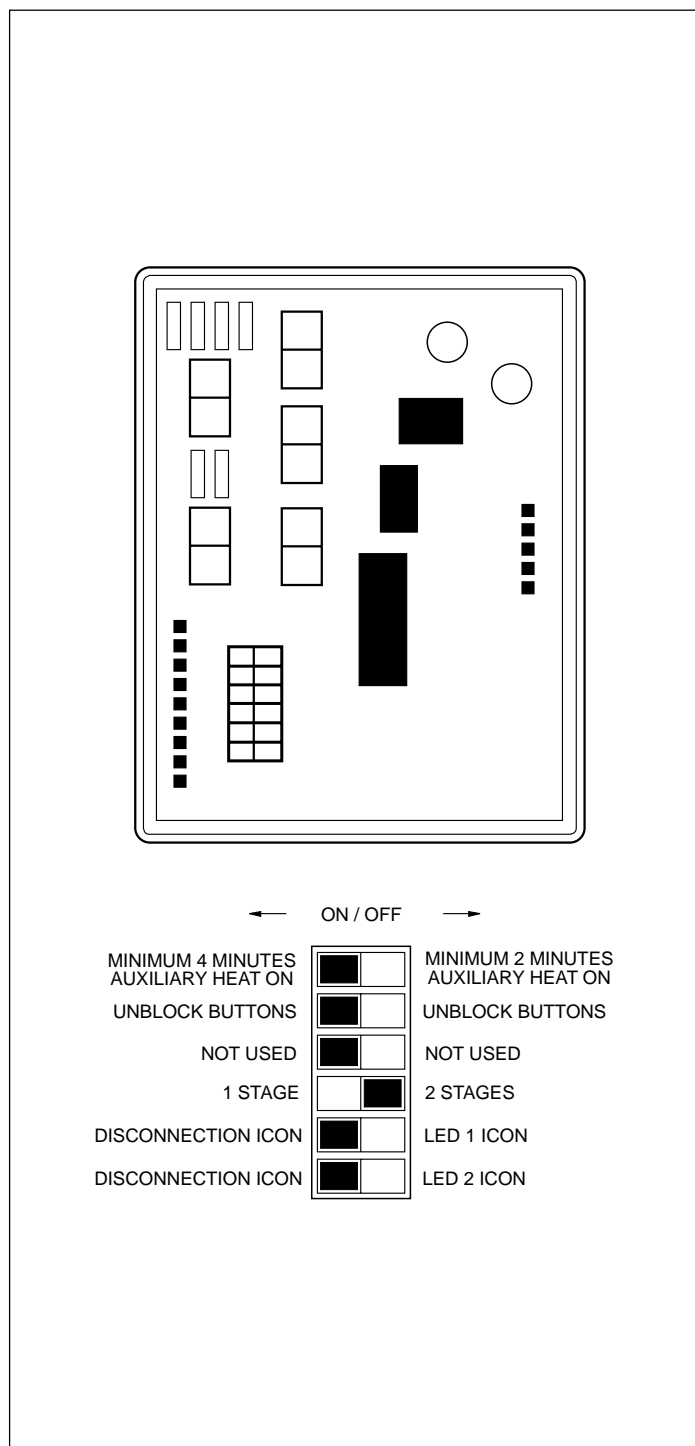

### Graphic information

The display panel permanently provides us with information concerning: the ambient temperature, operational mode, day/night, and fan operation. To receive information concerning the set temperatures it is only necessary to press one of the temperature selection buttons once, and the established set temperature for the operational mode which is being displayed at that time will appear on the panel for 5 seconds.

## Maintenance

Clean the casing with a vacuum cleaner or a cloth moistened in a mild liquid detergent.

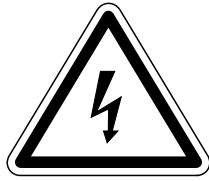

Do not use water to clean the indoor unit. Water may damage the internal components and cause electrical discharges.



**CAUTION**

Check the outdoor unit periodically to see whether either the outlet or the inlet are blocked up with dirt or leaves, etc. The internal coil and other components of the outdoor unit must also be periodically cleaned. Contact your concessionary or maintenance service.

## Indoor unit outflow ducts

The indoor unit outflow, intended for ducts, is supplied without a protective grill. When maintenance work is being done this must be taken into account.



**CAUTION**

In cases of an restricted outflow installations for an indoor unit intended for ducting, the outlet opening must be protected with a grill. Failure to fit this protection could result in damages being caused by the fan turbine.

## Priming the drainage siphon

To avoid problems with water from condensation we recommend that the drainage siphon be primed when starting up and before the beginning of each season so as to avoid, from the very beginning, the intake of air into this pipe.

## Checking drive belt tension

Each year the tension and wear on the drive belts of the motor must be checked, and if necessary they must be changed. Before making the check disconnect the mains supply switch.



**CAUTION**

For safety reasons make sure that you switch off the air-conditioner, also disconnecting it from the mains supply, before checking the fan motor drive belts.

## Cleaning the filters

Keep the battery filters in good condition, servicing them at least once a month. If the filters are dirty they will reduce the air-flow and the performance of the unit.

## Cleaning the outdoor

Dirt must not be allowed to accumulate on the outdoor unit. This must be cleaned as often as necessary with a brush, vacuum cleaner or detergent.



**CAUTION**

For safety reasons make sure to switch off the air-conditioner, and to disconnect it from the mains before cleaning.

## Access to the units for maintenance servicing



Attention: The unit has a remote control system and can start automatically. Two minutes prior to having access to the interior, the power supply should be disconnected so as to avoid any contact with the fan turbine in operation.

# General dimensions mm

## BCVI-20 & 25

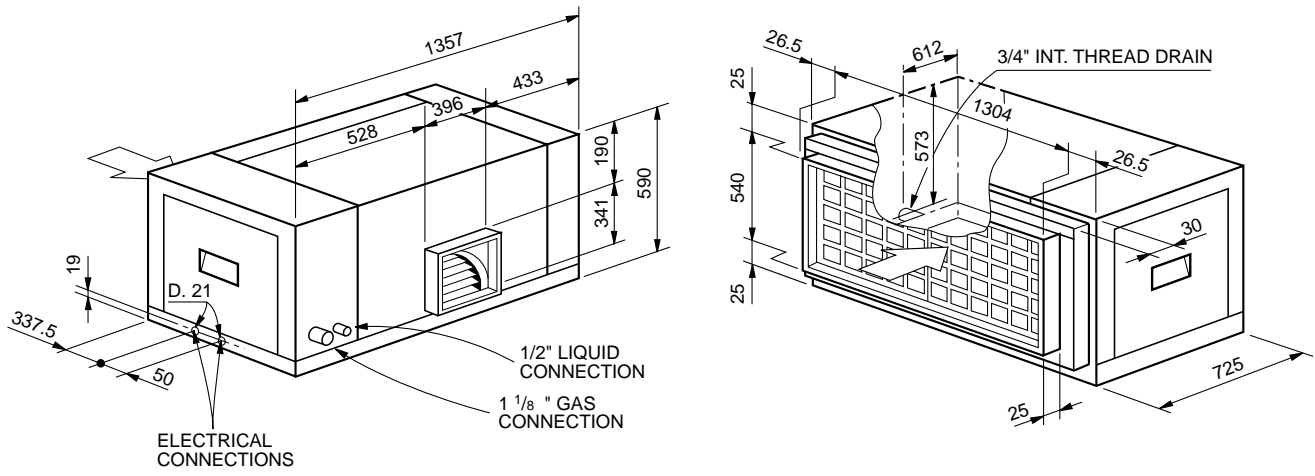

## BCVO-20 & 25

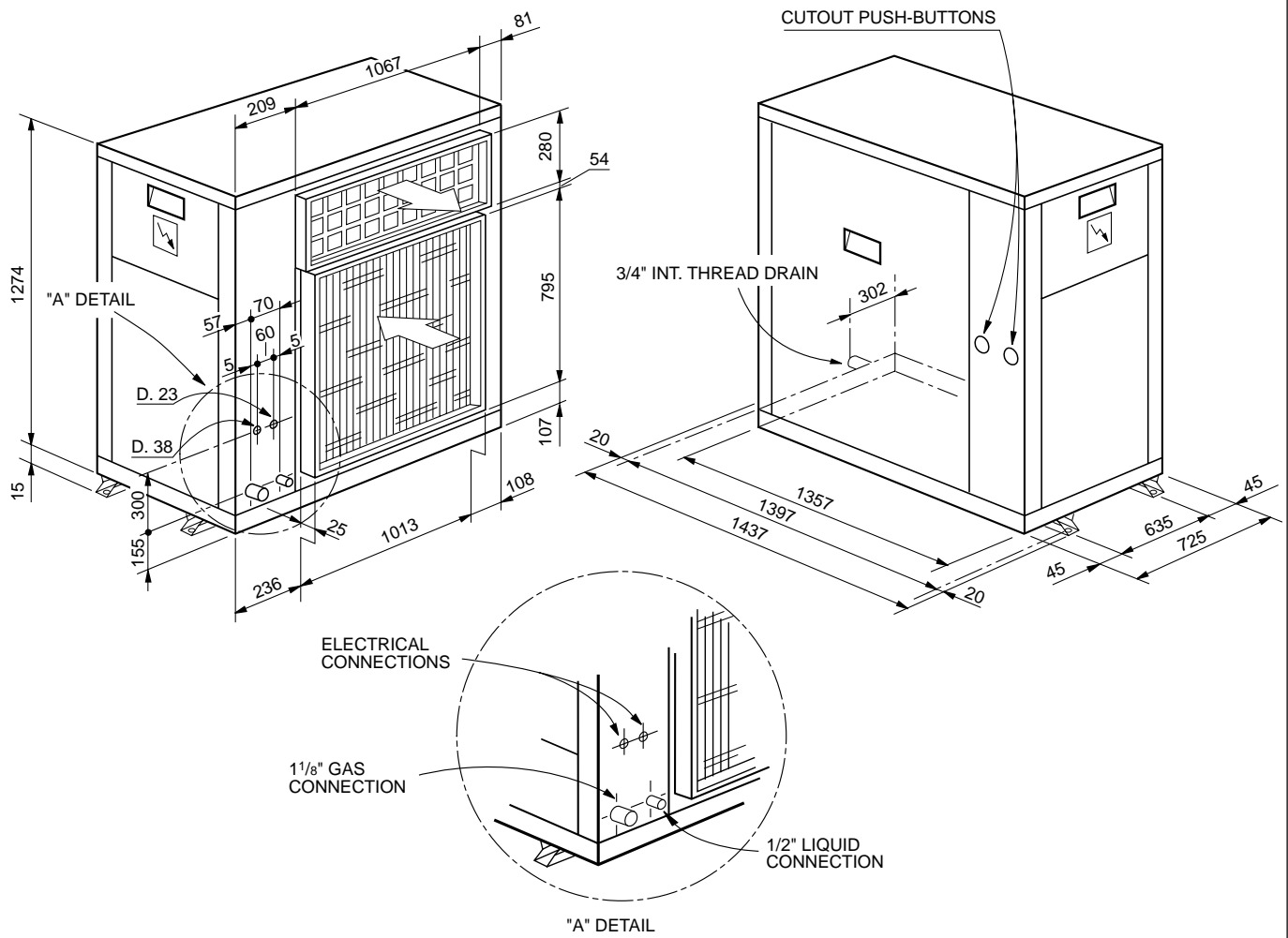

# General dimensions mm

## BCVI-30 & 40

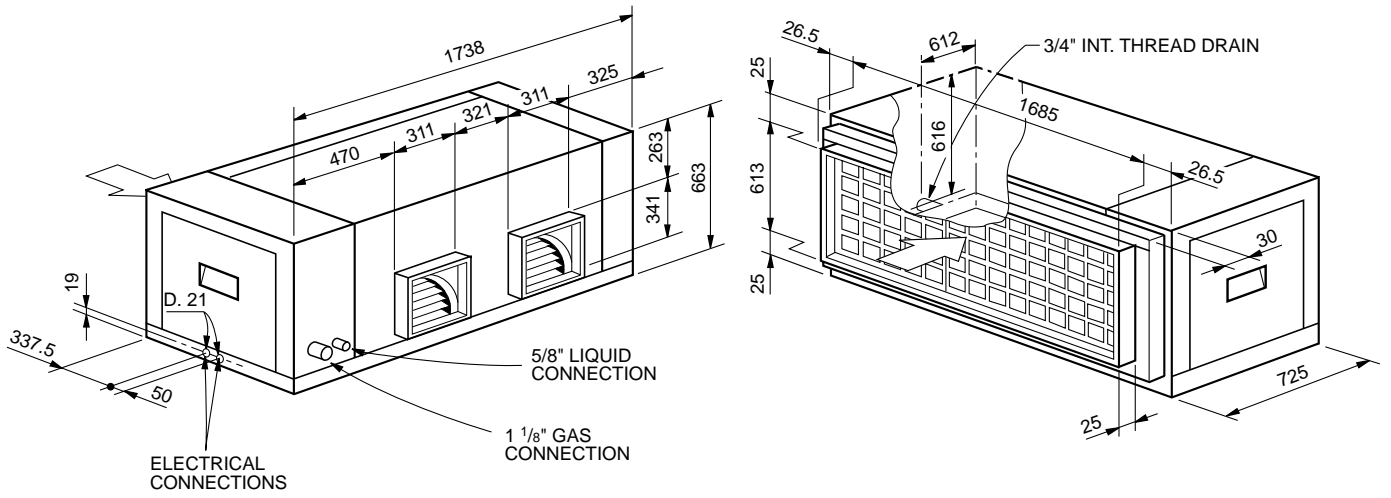

## BCVO-30 & 40

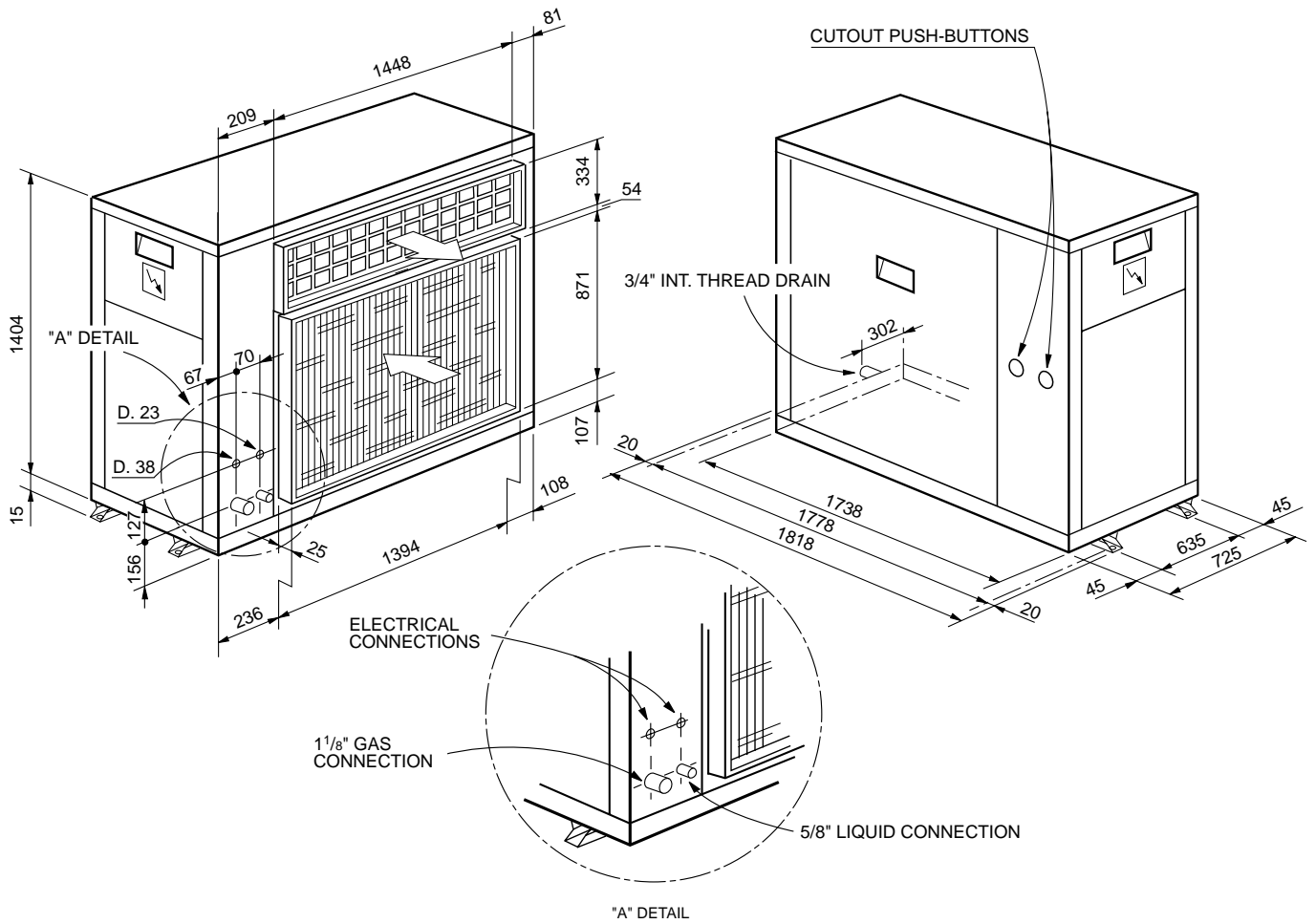

# General dimensions mm

## BCVI-45

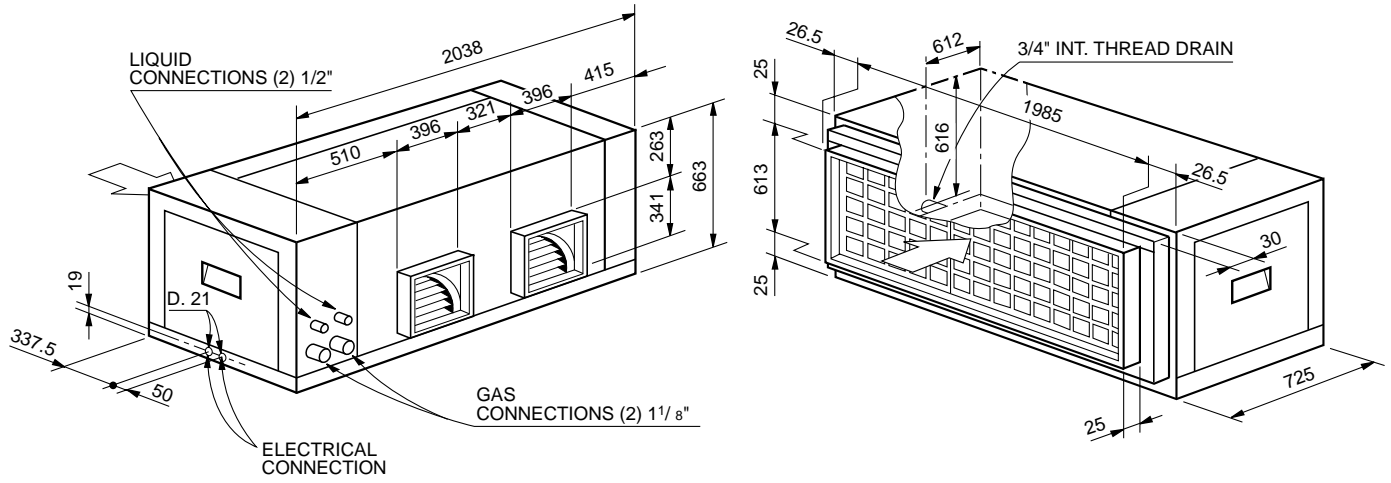

## BCVO-45

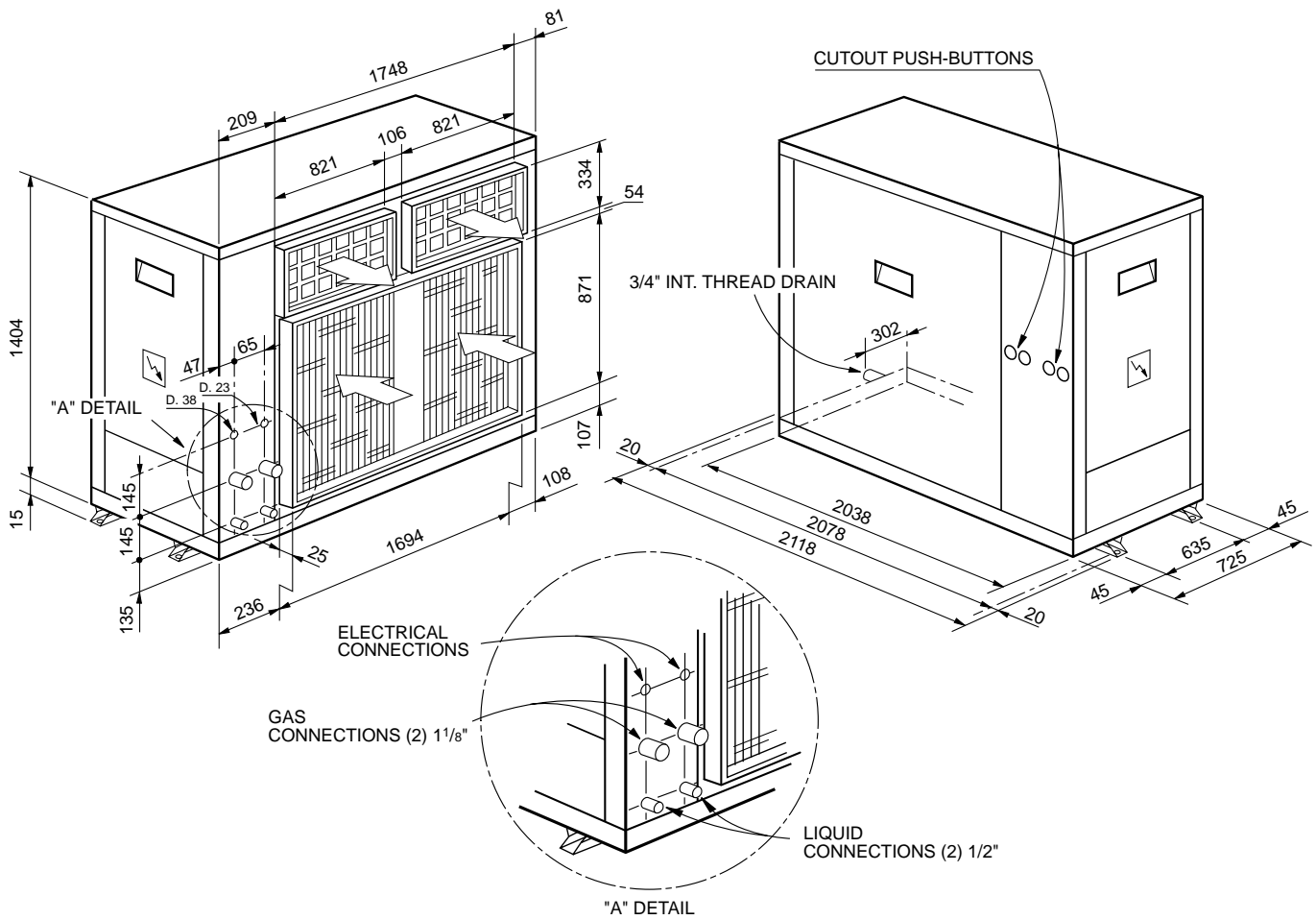

# General dimensions mm

## BCVI-60

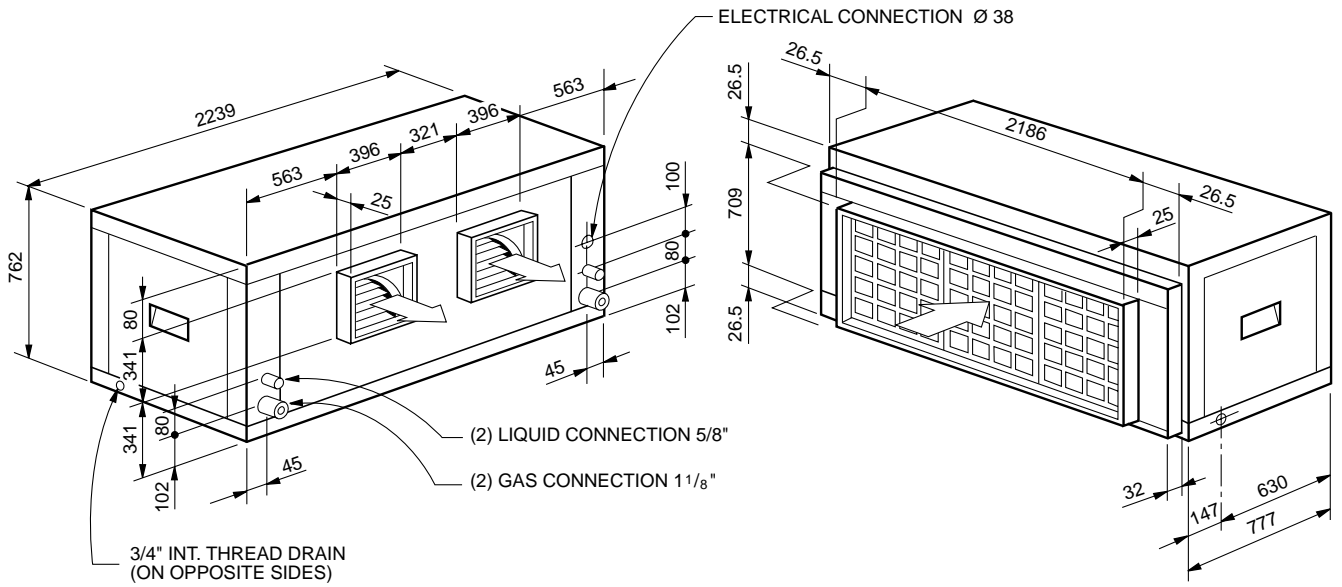

## BCVO-60 BCVO-80

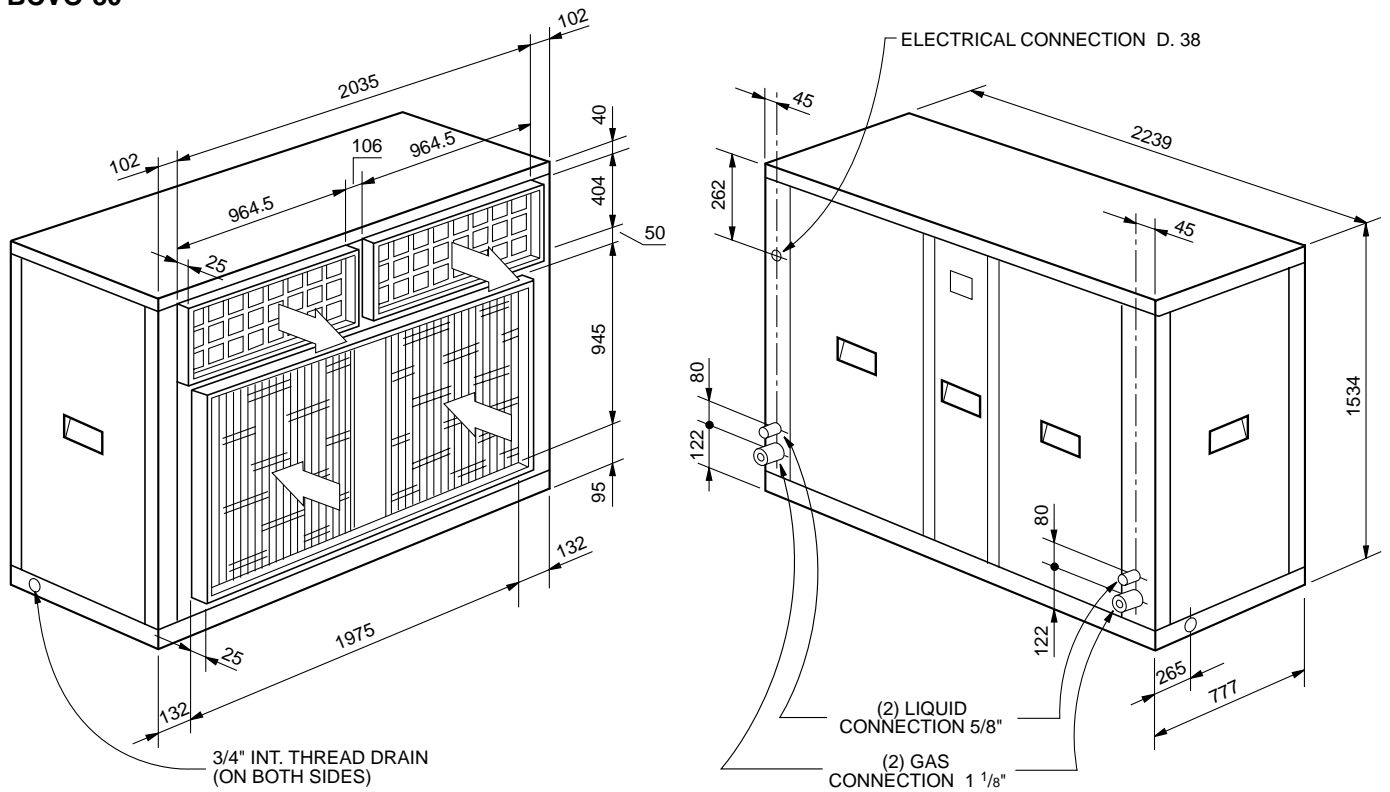



# Connections diagram

BCVO/I-20, 25, 30 & 40, 230.3.50

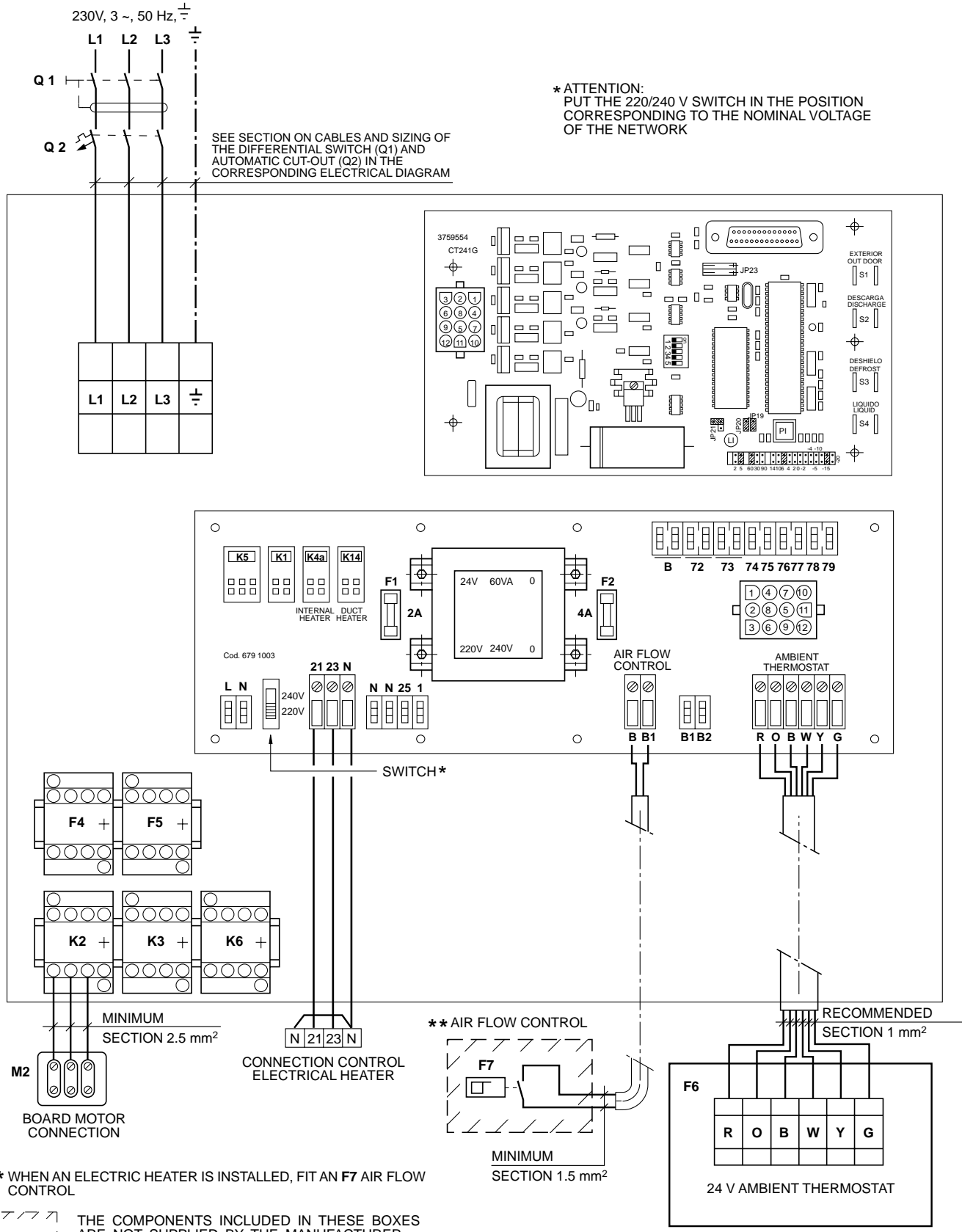

**\* ATTENTION:**  
PUT THE 220/240 V SWITCH IN THE POSITION  
CORRESPONDING TO THE NOMINAL VOLTAGE  
OF THE NETWORK

SEE SECTION ON CABLES AND SIZING OF  
THE DIFFERENTIAL SWITCH (Q1) AND  
AUTOMATIC CUT-OUT (Q2) IN THE  
CORRESPONDING ELECTRICAL DIAGRAM

**\*\* WHEN AN ELECTRIC HEATER IS INSTALLED, FIT AN F7 AIR FLOW CONTROL**

- THE COMPONENTS INCLUDED IN THESE BOXES ARE NOT SUPPLIED BY THE MANUFACTURER.
- THE COMPONENTS INCLUDED IN THESE BOXES ARE STANDARD ACCESSORIES SUPPLIED BY THE MANUFACTURER.

I-1283/j  
BCVO/I-20, 25, 30 & 40  
230.3.50

# Connections diagram

BCVO/I-20, 25, 30 & 40, 400.3.50

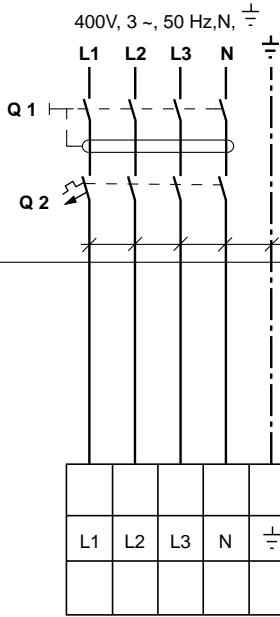

SEE SECTION ON CABLES AND SIZING OF THE DIFFERENTIAL SWITCH (Q1) AND AUTOMATIC CUT-OUT (Q2) IN THE CORRESPONDING ELECTRICAL DIAGRAM

\* ATTENTION:  
PUT THE 220/240 V SWITCH IN THE POSITION CORRESPONDING TO THE NOMINAL VOLTAGE OF THE NETWORK

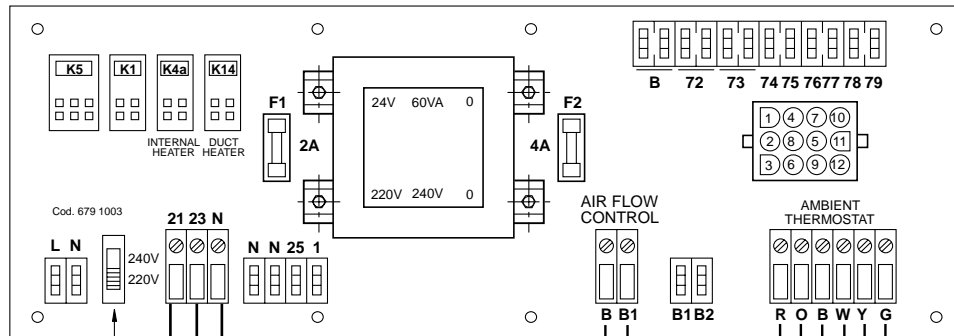
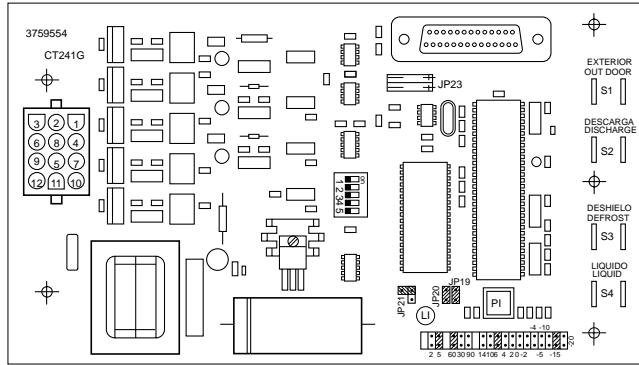

SWITCH \*

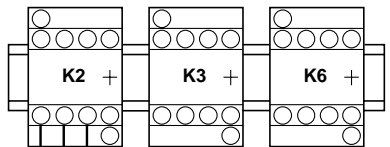
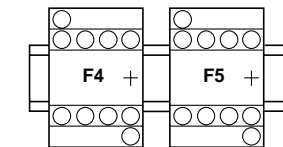

MINIMUM SECTION 1.5 mm<sup>2</sup>

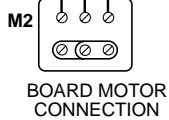

CONNECTION CONTROL ELECTRIC HEATER

\*\* AIR FLOW CONTROL

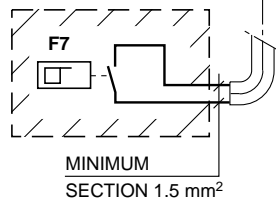

RECOMMENDED SECTION 1 mm<sup>2</sup>

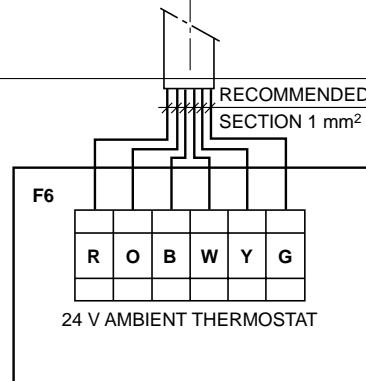

\*\* WHEN AN ELECTRIC HEATER IS INTALLED, FIT AN F7 AIR FLOW CONTROL

THE COMPONENTS INCLUDED IN THESE BOXES ARE NOT SUPPLIED BY THE MANUFACTURER.

THE COMPONENTS INCLUDED IN THESE BOXES ARE STANDARD ACCESSORIES SUPPLIED BY THE MANUFACTURER.

I-1284/j  
BCVO/I-20,25,30 & 40  
400.3.50





# Power diagram

BCVO/I-30, 230.3.50

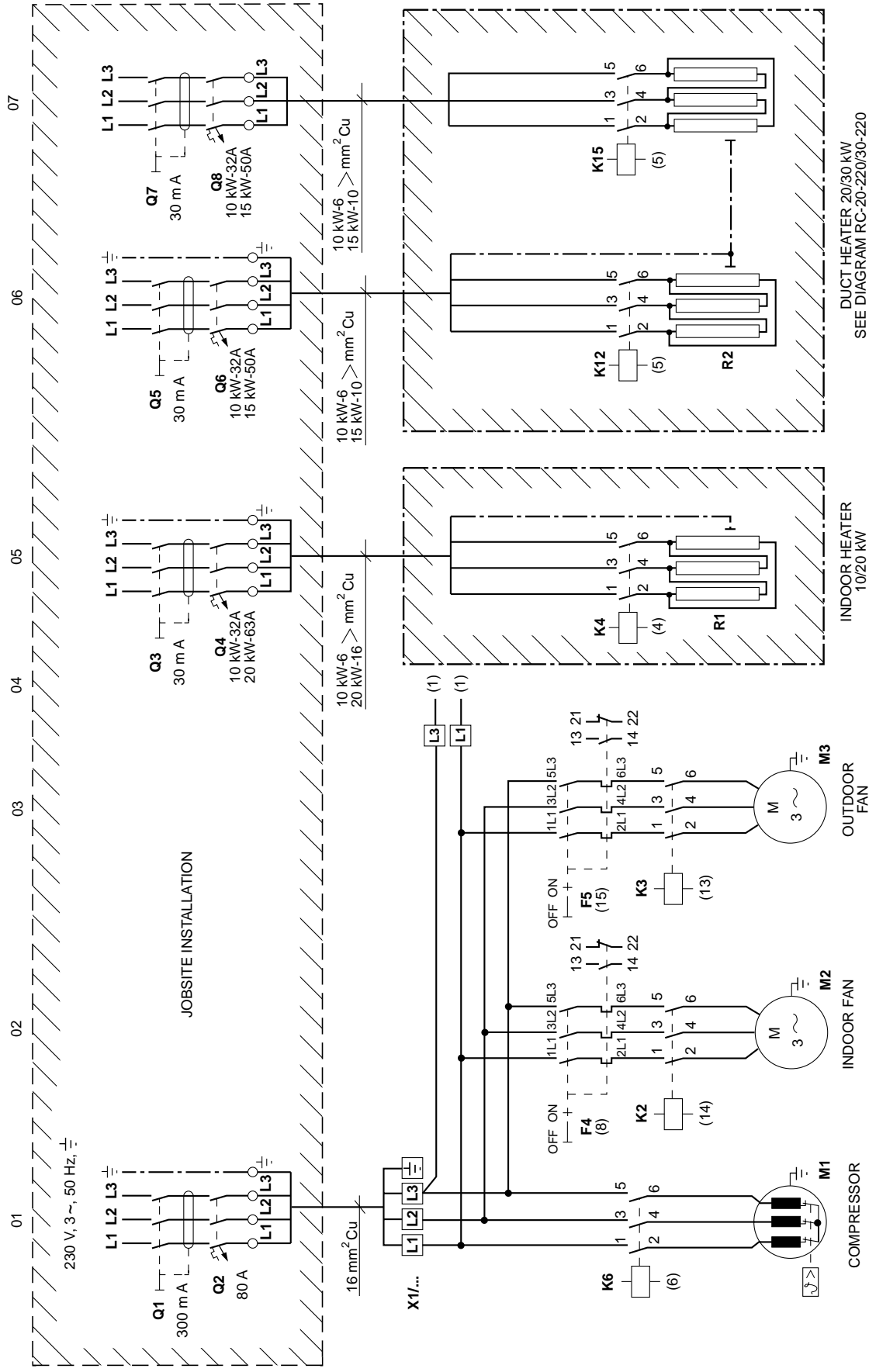

 THE COMPONENTS INCLUDED IN THESE BOXES ARE NOT SUPPLIED BY THE MANUFACTURER.  
 THE COMPONENTS INCLUDED IN THESE BOXES ARE STANDARD ACCESSORIES SUPPLIED BY THE MANUFACTURER.

DUCT HEATER 20/30 kW  
SEE DIAGRAM RC-20-220/30-220

INDOOR HEATER  
10/20 kW

I-1291/f  
BCVO/I-30,230.3.50

# Power diagram

BCVO/I-40, 230.3.50

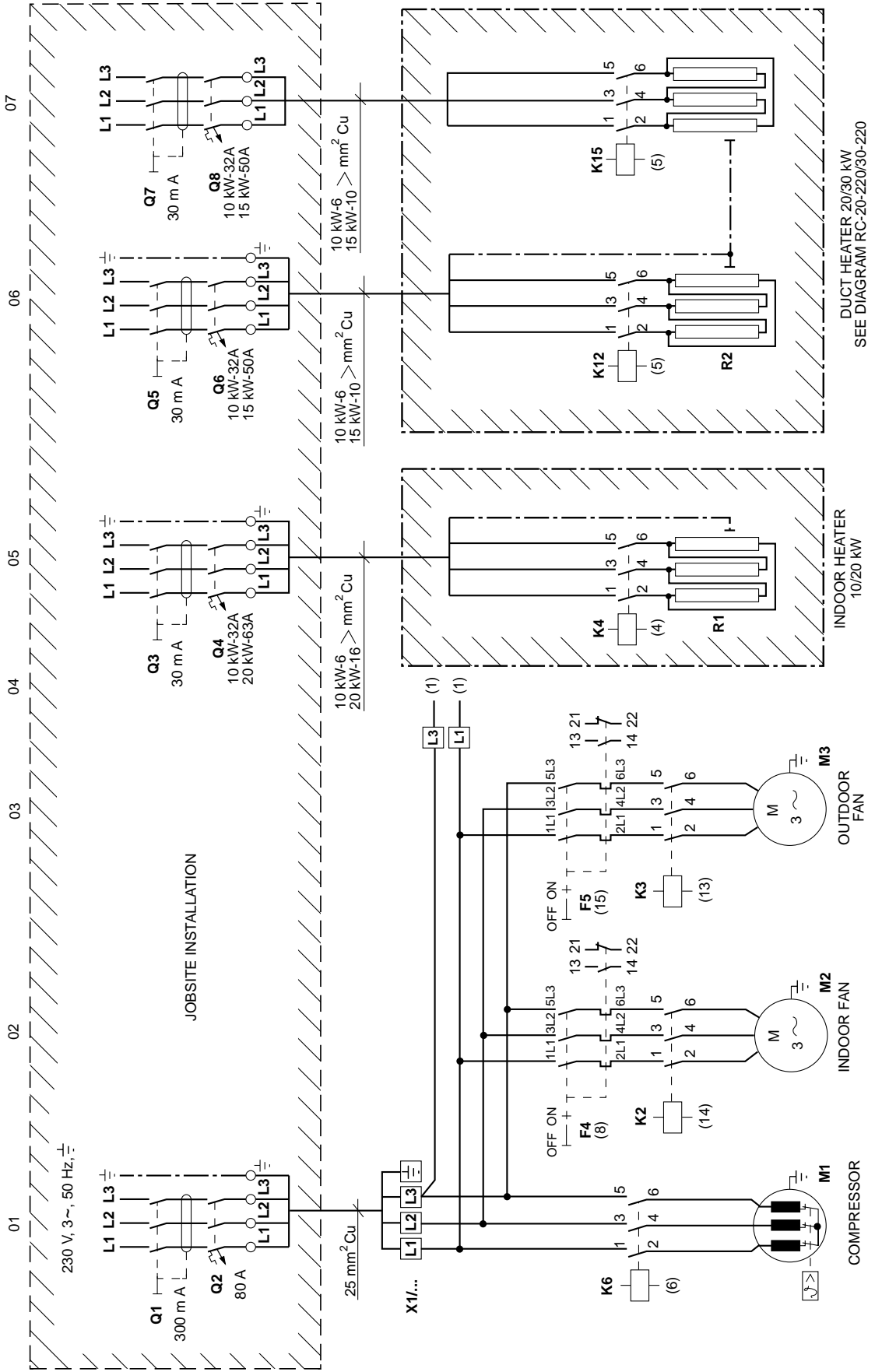

 THE COMPONENTS INCLUDED IN THESE BOXES ARE NOT SUPPLIED BY THE MANUFACTURER.  
 THE COMPONENTS INCLUDED IN THESE BOXES ARE STANDARD ACCESSORIES SUPPLIED BY THE MANUFACTURER.

DUCT HEATER 20/30 kW  
SEE DIAGRAM RC-20-220/30-220

I-1292/f  
BCVO/I-40,230.3.50

# Power diagram

BCVO/I-30 & 40, 400.3.50

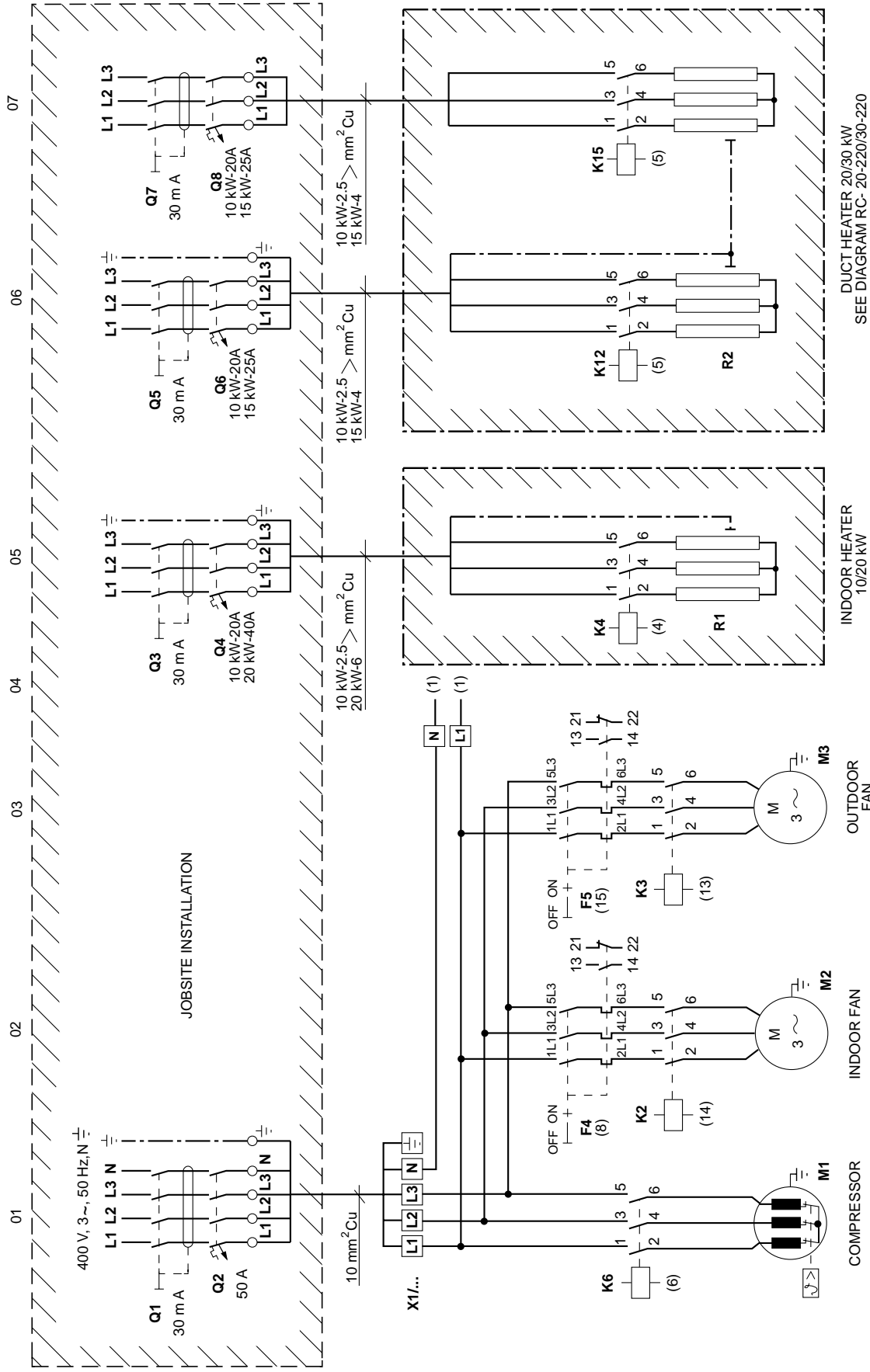

 THE COMPONENTS INCLUDED IN THESE BOXES ARE NOT SUPPLIED BY THE MANUFACTURER.  
 THE COMPONENTS INCLUDED IN THESE BOXES ARE STANDARD ACCESSORIES SUPPLIED BY THE MANUFACTURER.

DUCT HEATER 20/30 kW  
SEE DIAGRAM RC- 20-220/30-220

INDOOR HEATER  
10/20 kW

INDOOR FAN

INDOOR FAN

COMPRESSOR

OUTDOOR FAN

I-1300/f  
BCVO/I-30 & 40,400.3.50

# Control diagram

BCVO/I-20, 25, 30 & 40, 230.3.50, 400.3.50

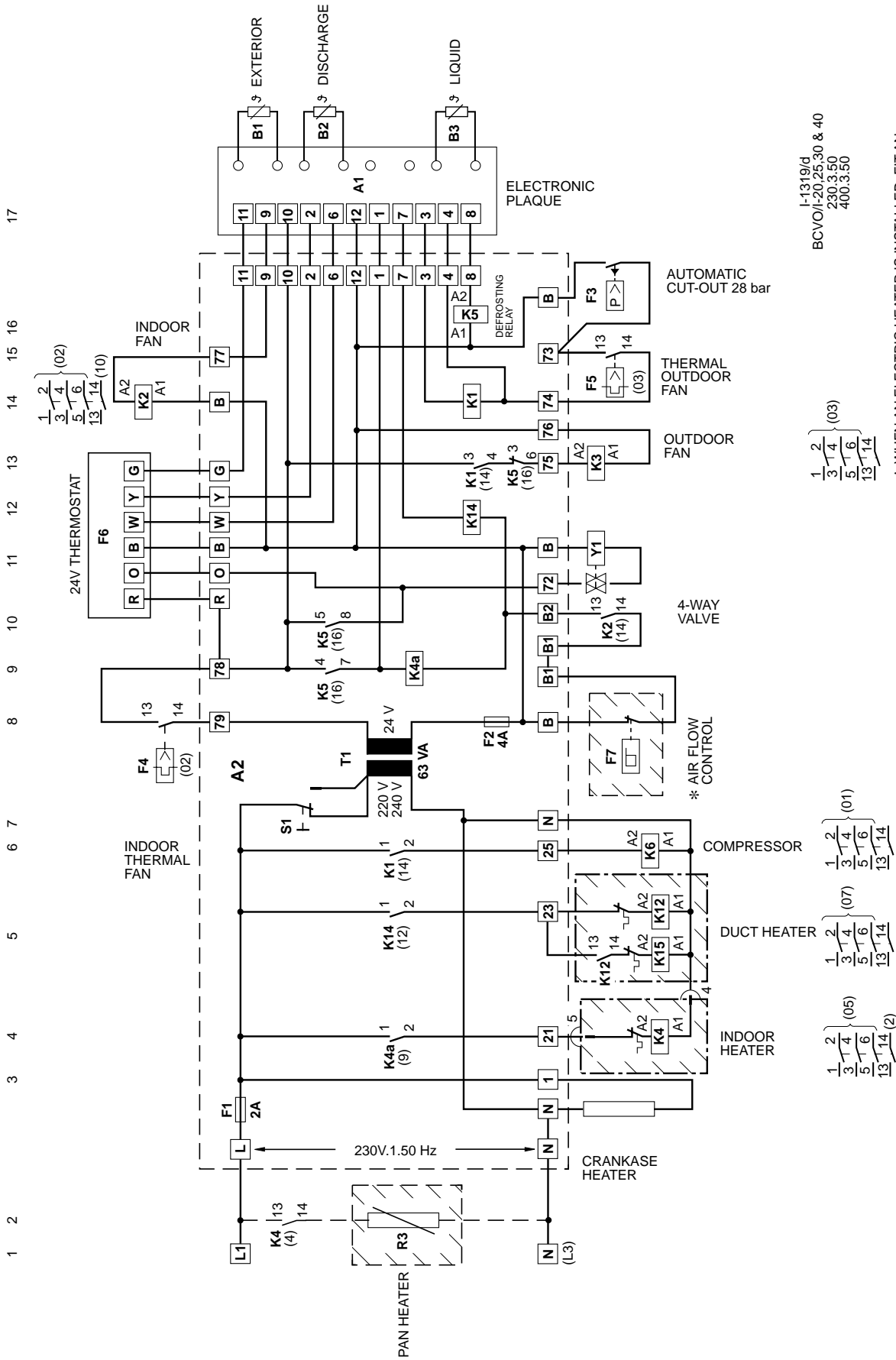

I-1319/d  
BCVO/I-20,25,30 & 40  
230.3.50  
400.3.50

1-2 (03)  
3-4 (03)  
5-6 (03)  
13-14 (03)

1-2 (01)  
3-4 (07)  
5-6 (05)  
13-14 (2)

\* WHEN AN ELECTRIC HEATER IS INSTALLED, FIT AN F7 AIR FLOW CONTROL

THE COMPONENTS INCLUDED IN THESE BOXES ARE NOT SUPPLIED BY THE MANUFACTURER.  
THE COMPONENTS INCLUDED IN THESE BOXES ARE STANDARD ACCESSORIES SUPPLIED BY THE MANUFACTURER.

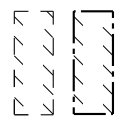

# Interconnection diagram

BCVO/I-45, 400.3.50

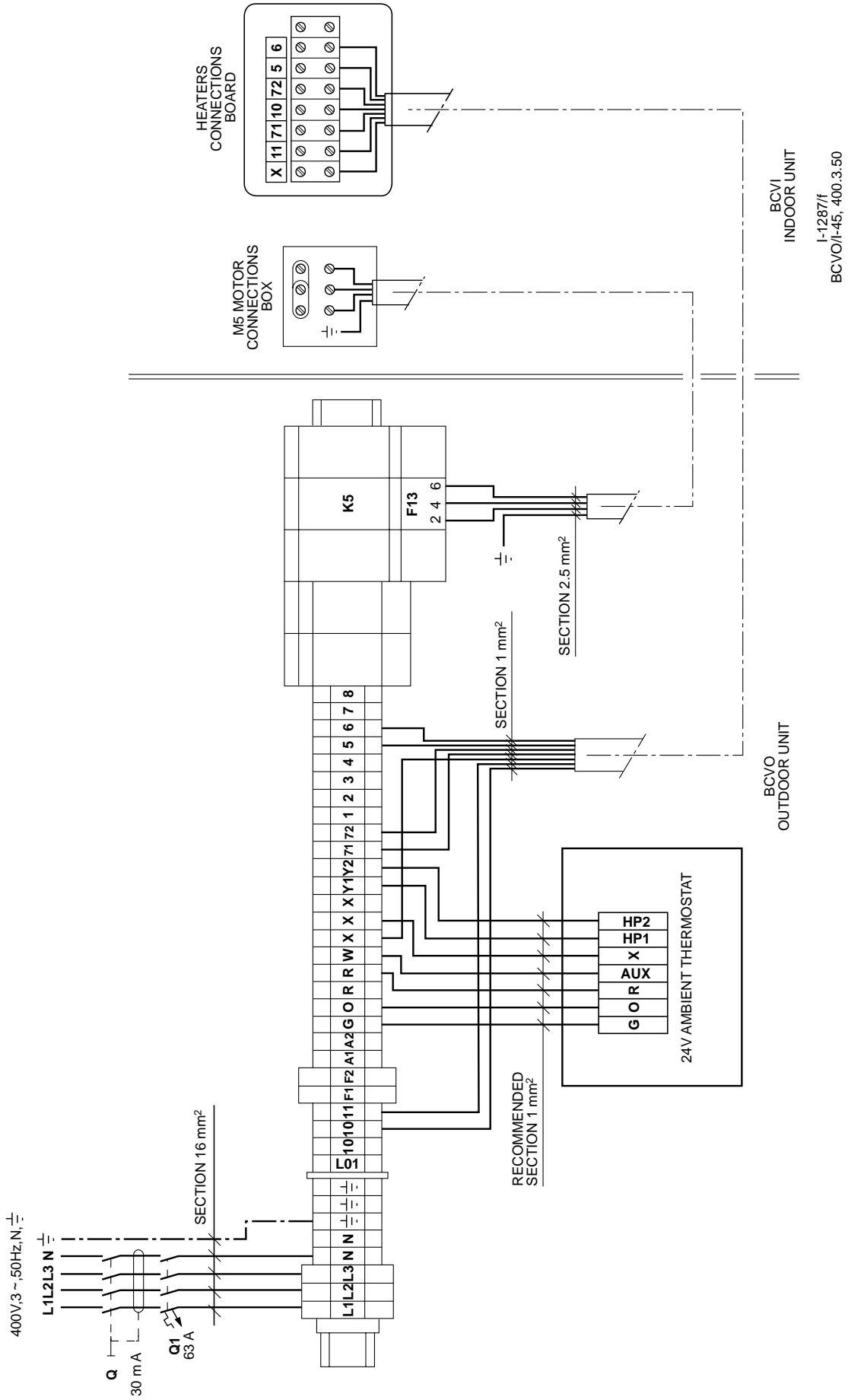

BCVO/I-45, 400.3.50

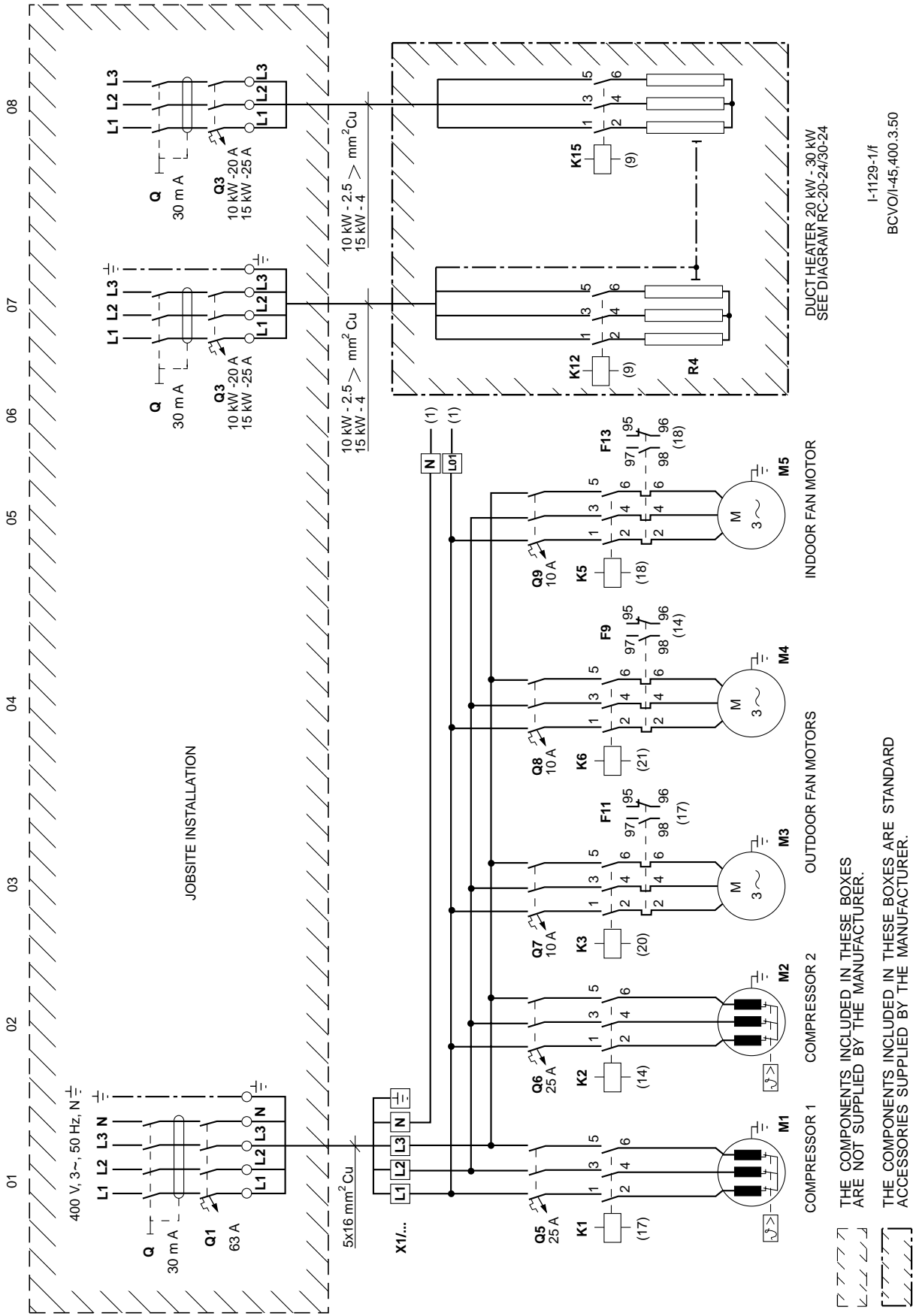

# Control diagram

BCVO/I-45, 400.3.50 (1 of 2)

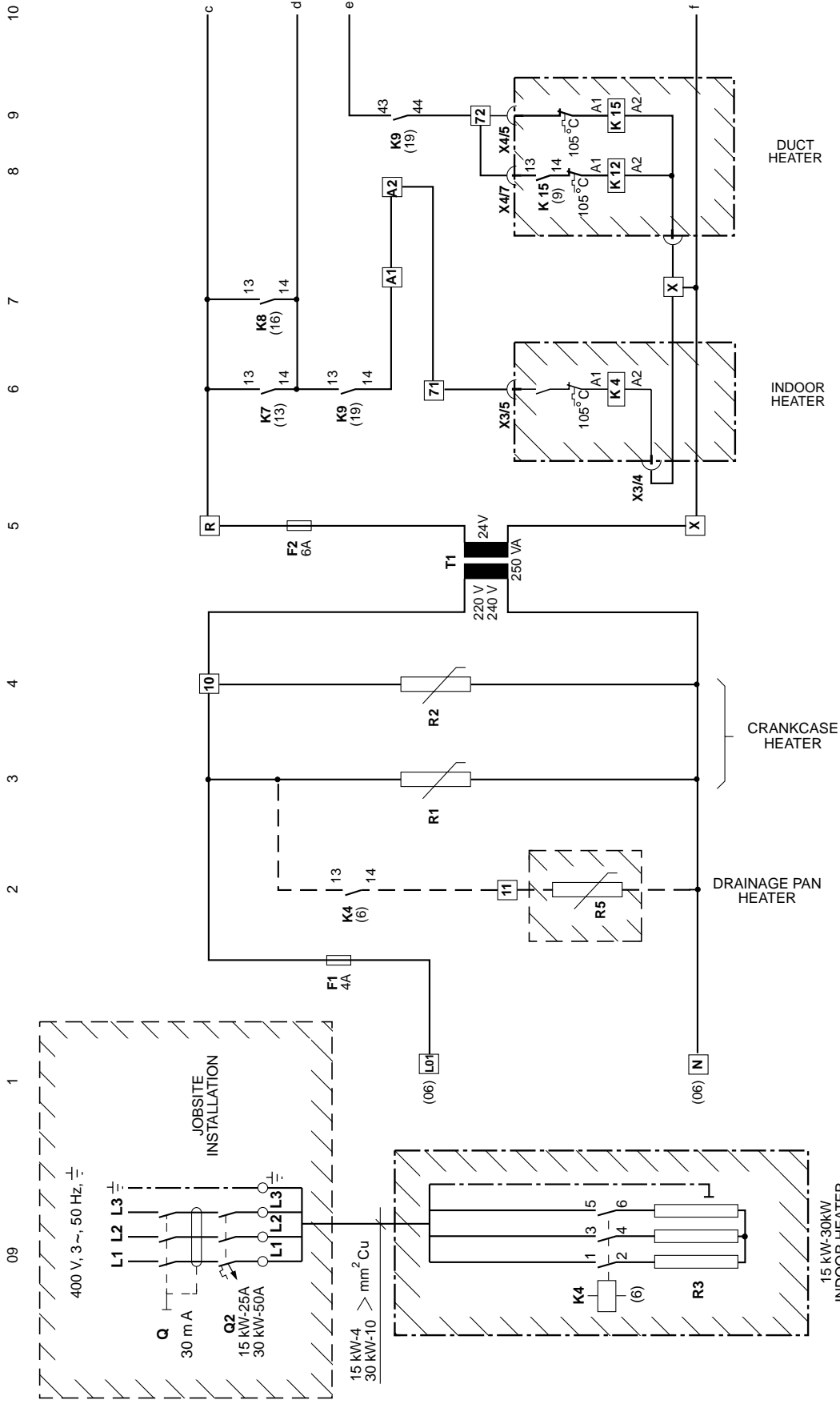

THE COMPONENTS INCLUDED IN THESE BOXES ARE NOT SUPPLIED BY THE MANUFACTURER.

THE COMPONENTS INCLUDED IN THESE BOXES ARE STANDARD ACCESSORIES SUPPLIED BY THE MANUFACTURER.

I-1129-2/f  
BCVO/I-45,400.3.50 (1 of 2)

# Control diagram

BCVO/I-45, 400.3.50 (2 of 2)

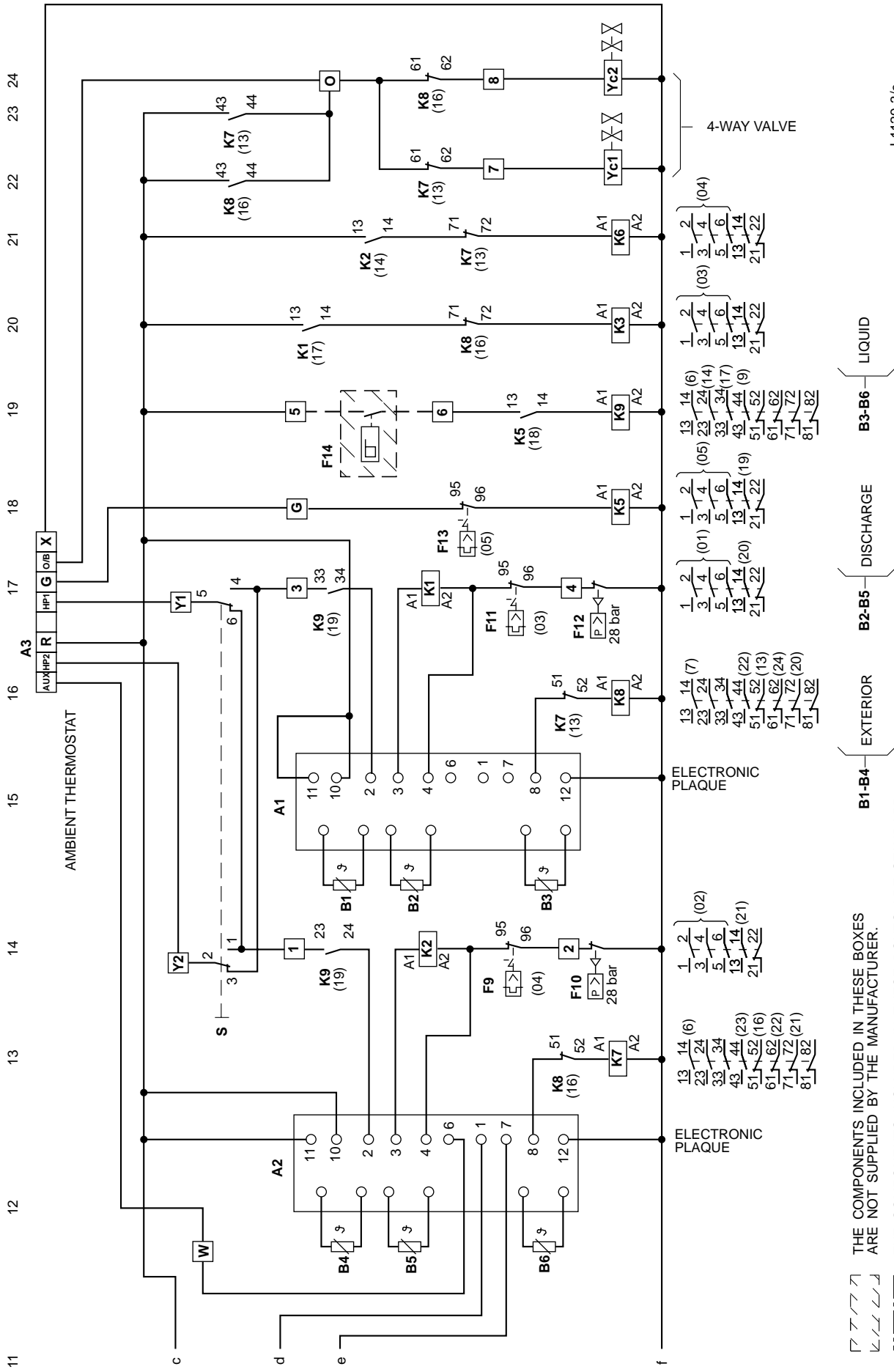

I-1129-3/e  
BCVO/I-45, 400.3.50 (2 of 2)

LIQUID  
DISCHARGE  
EXTERIOR  
B1-B4  
B2-B5  
B3-B6

THE COMPONENTS INCLUDED IN THESE BOXES ARE NOT SUPPLIED BY THE MANUFACTURER.  
THE COMPONENTS INCLUDED IN THESE BOXES ARE STANDARD ACCESSORIES SUPPLIED BY THE MANUFACTURER.

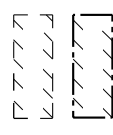

# Interconnection diagram

BCVO/I-60, 400.3.50

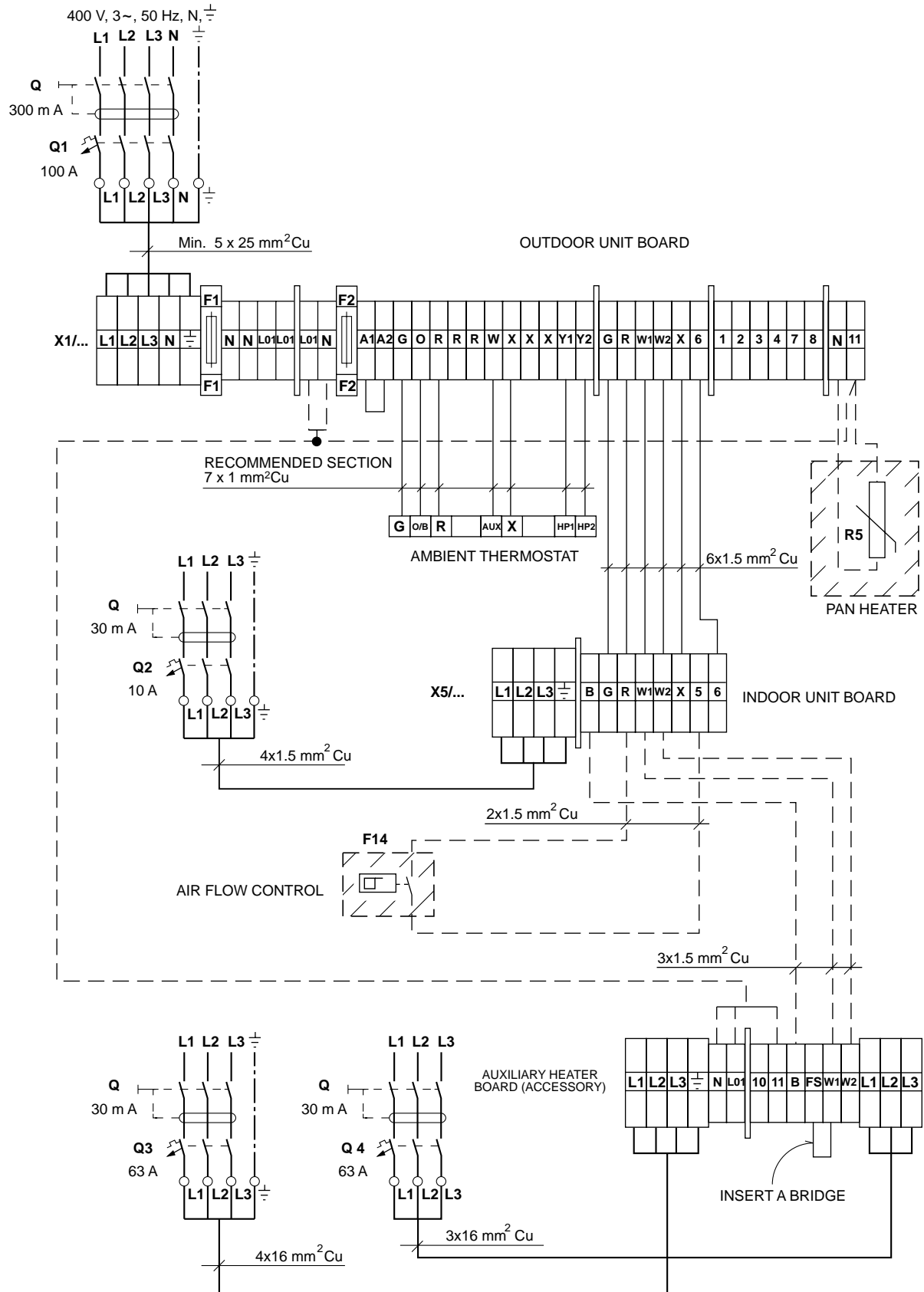

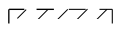
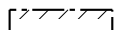
-  THE COMPONENTS INCLUDED IN THESE BOXES ARE NOT SUPPLIED BY THE MANUFACTURER.
-  THE COMPONENTS INCLUDED IN THESE BOXES ARE STANDARD ACCESSORIES SUPPLIED BY THE MANUFACTURER.

I-1155-4/h  
BCVO/I-60,400.3.50

# Power diagram

BCVO/I-60, 400.3.50

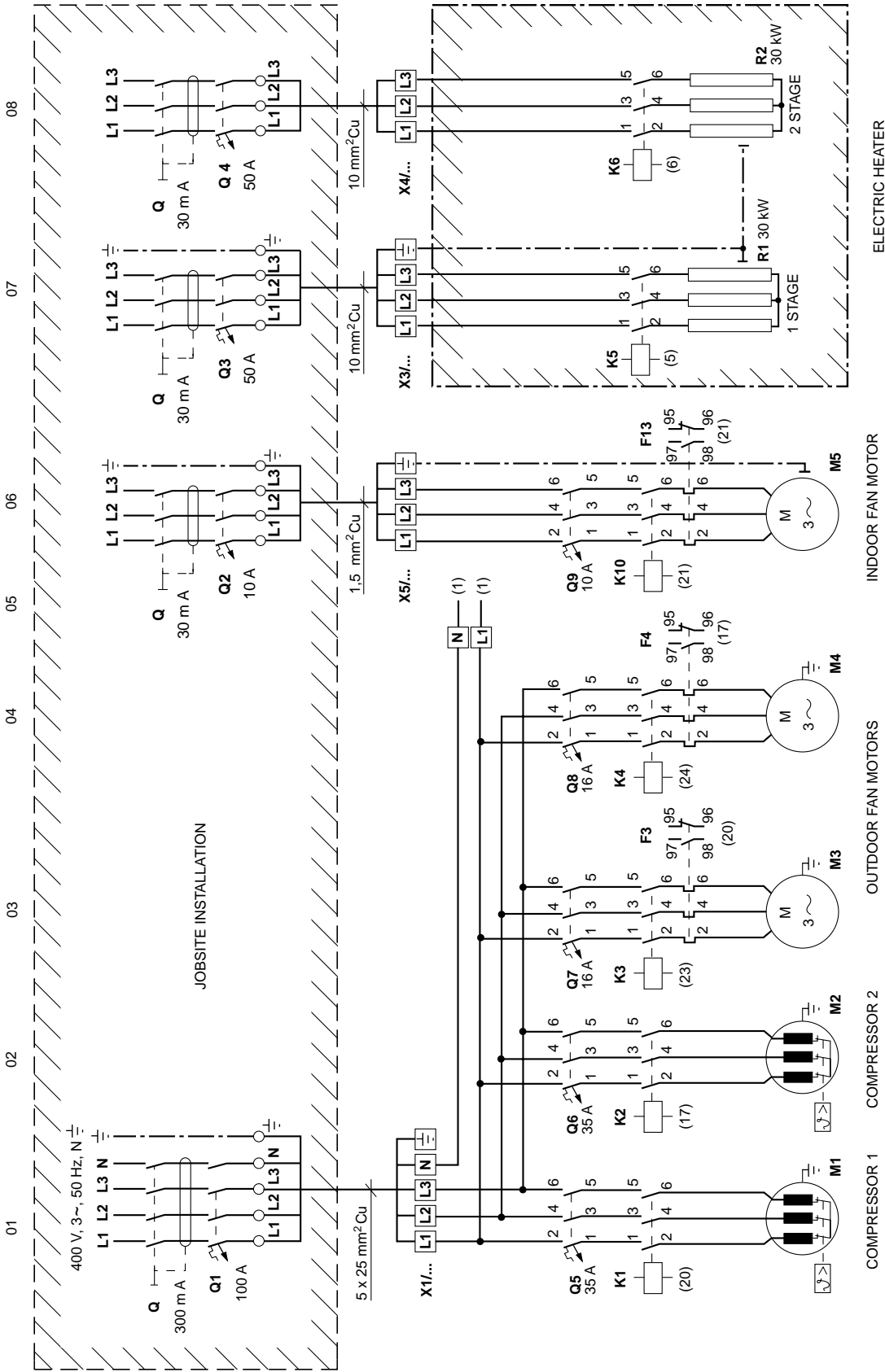

THE COMPONENTS INCLUDED IN THESE BOXES ARE NOT SUPPLIED BY THE MANUFACTURER.

THE COMPONENTS INCLUDED IN THESE BOXES ARE STANDARD ACCESSORIES SUPPLIED BY THE MANUFACTURER.

ELECTRIC HEATER

INDOOR FAN MOTOR

OUTDOOR FAN MOTORS

COMPRESSOR 1 COMPRESSOR 2

I-1155-1/f  
BCVO/I-60,400.3.50

# Control diagram

BCVO/I-60, 400.3.50 (1 of 2)

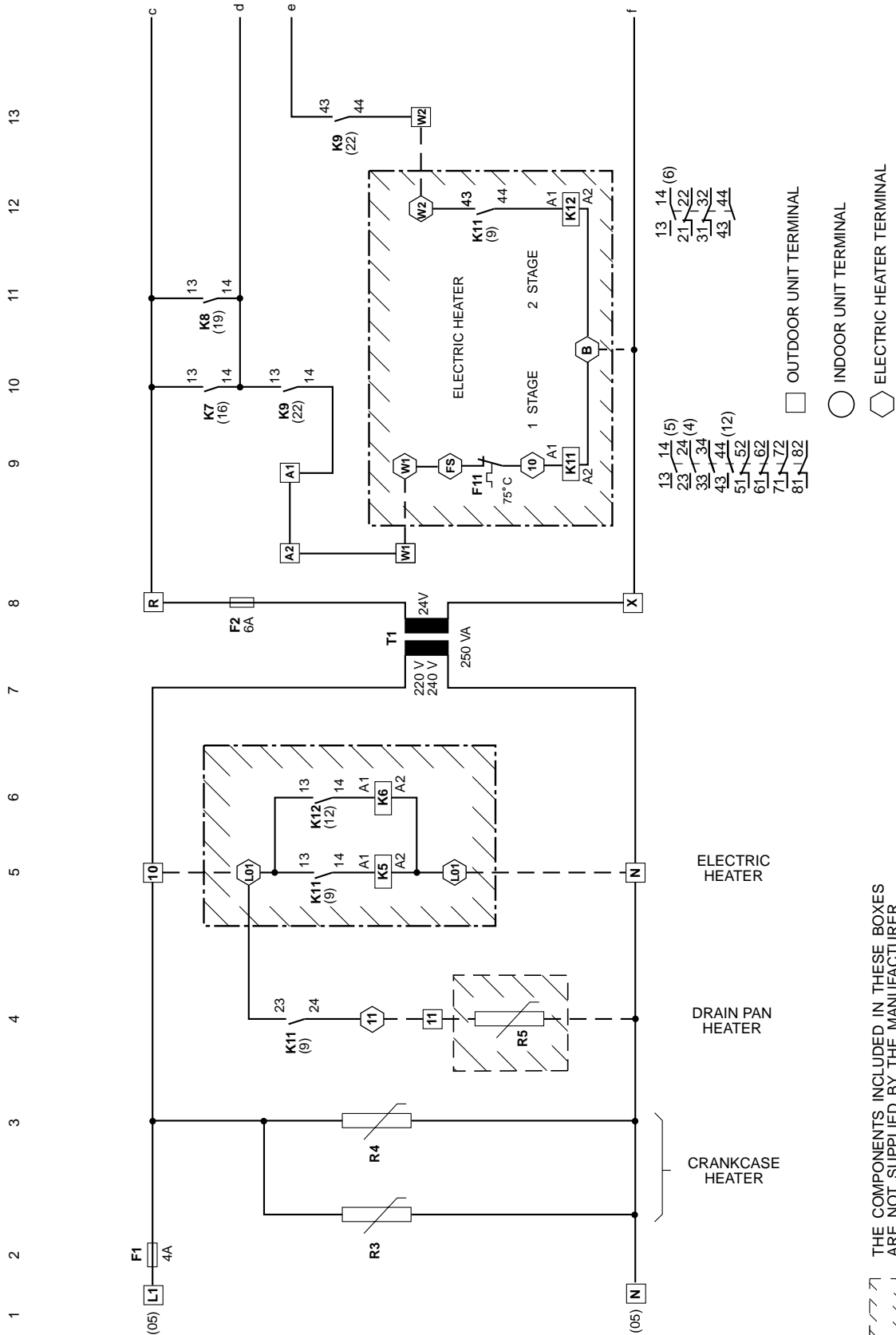

I-1155-2/d  
BCVO/I-60,400.3.50 (1 of 2)

THE COMPONENTS INCLUDED IN THESE BOXES ARE NOT SUPPLIED BY THE MANUFACTURER.

THE COMPONENTS INCLUDED IN THESE BOXES ARE STANDARD ACCESSORIES SUPPLIED BY THE MANUFACTURER.

# Control diagram

BCVO/I-60, 400.3.50 (2 of 2)

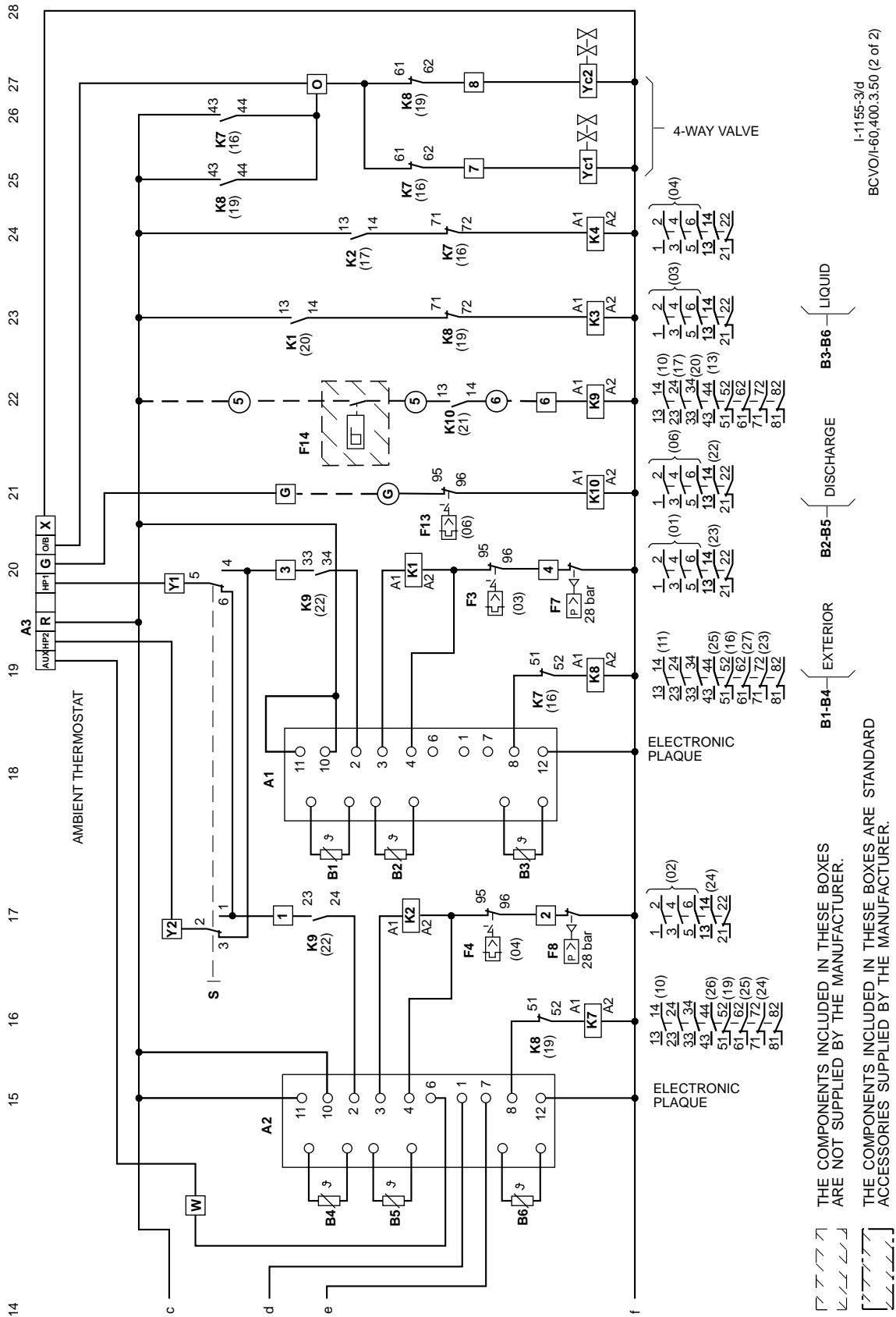

I-1155-3/d  
BCVO/I-60,400.3.50 (2 of 2)

# Interconnection diagram

BCVO-80/CHI-800, 400.3.50 (1 of 4)

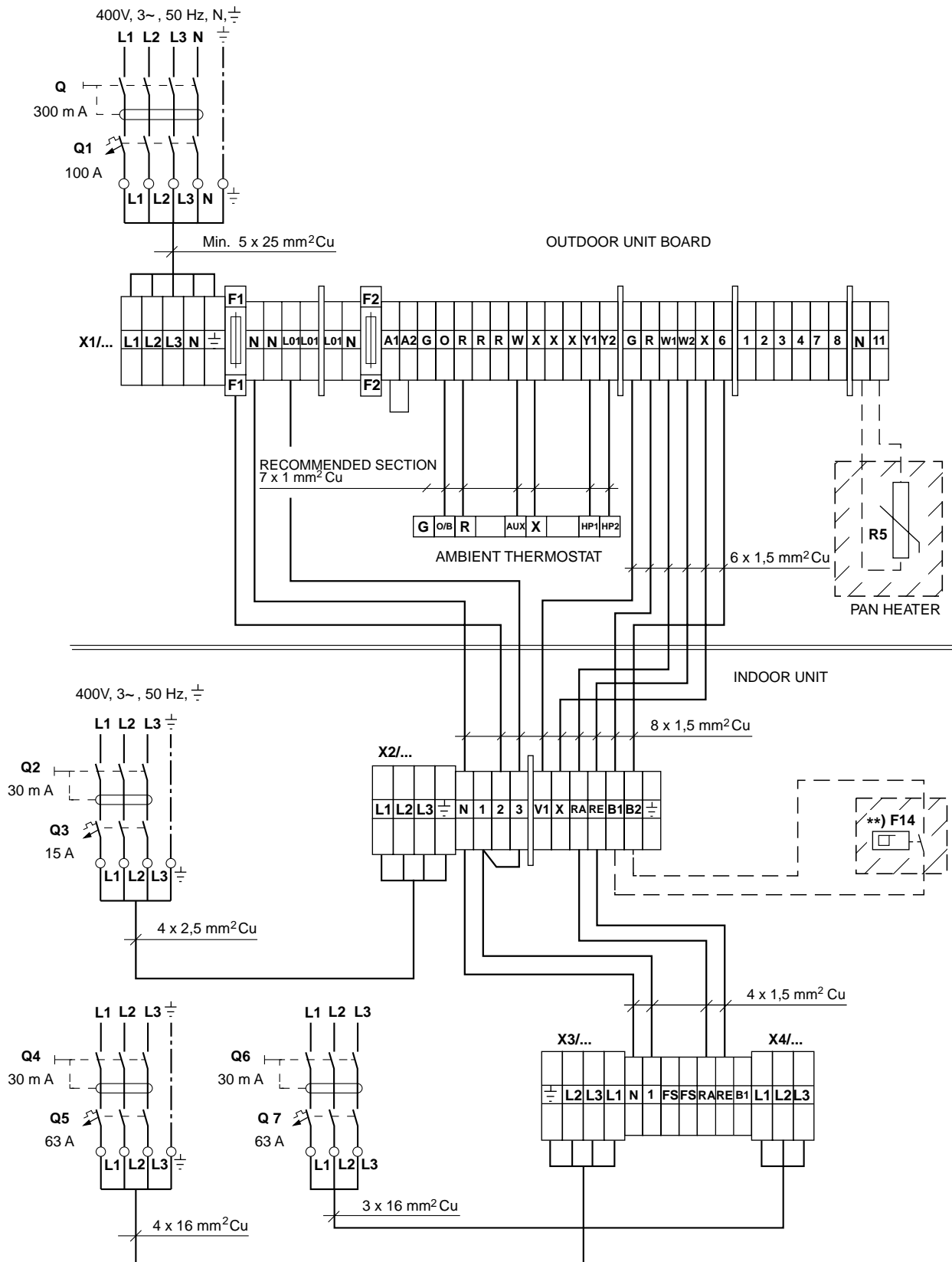

\*\* ) WHEN AN ELECTRIC HEATER IS INSTALLED, FIT AN F14 AIR FLOW CONTROL

$\square \ / \ / \ / \ /$  THE COMPONENTS INCLUDED IN THESE BOXES  
 $\square \ / \ / \ / \ /$  ARE NOT SUPPLIED BY THE MANUFACTURER.

I-1918/a (1 of 4)  
 BCVO-80/CHI-800  
 400.3.50

# Power diagram

BCVO-80, 400.3.50 (2 of 4)

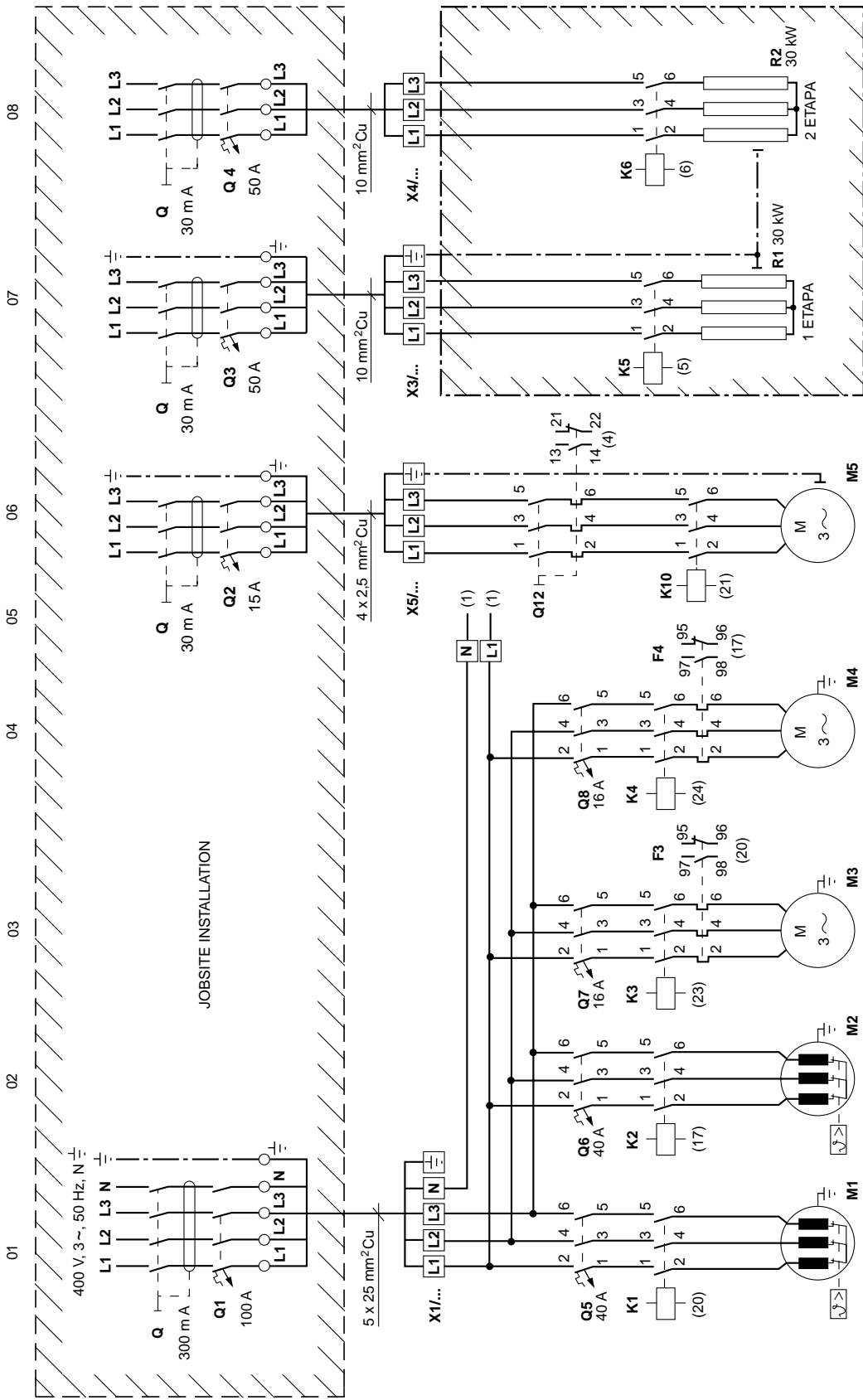

ELECTRIC HEATER

INDOOR FAN MOTOR

OUTDOOR FAN MOTORS

COMPRESOR 2

COMPRESOR 1

THE COMPONENTS INCLUDED IN THESE BOXES ARE NOT SUPPLIED BY THE MANUFACTURER.

THE COMPONENTS INCLUDED IN THESE BOXES ARE STANDARD ACCESSORIES SUPPLIED BY THE MANUFACTURER.

I-1918/a (2 of 4)  
BCVO-80,400.3.50

# Control diagram

BCVO-80, 400.3.50 (3 of 4)

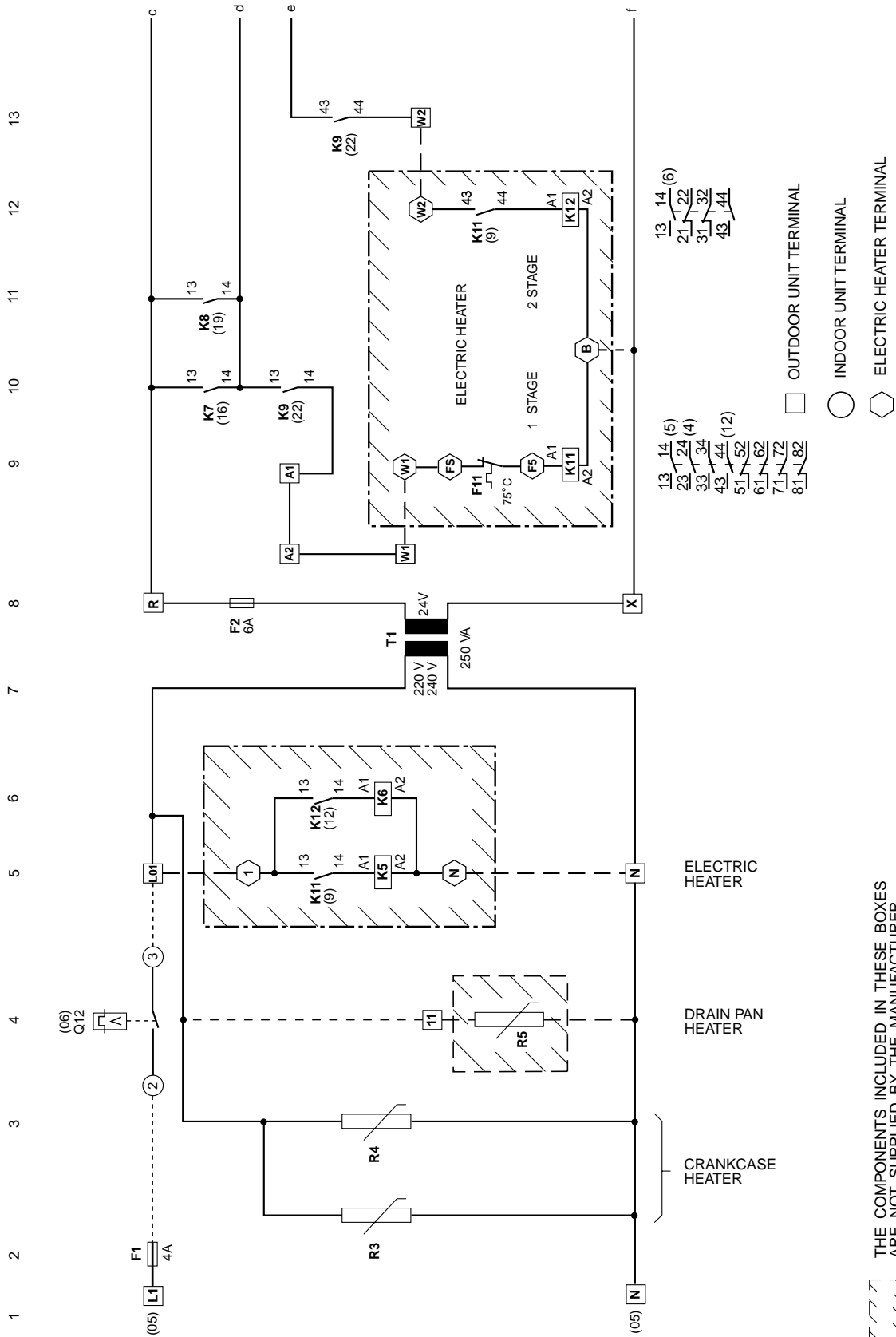

- 13 14 (5)
- 21 24 (4)
- 33 34
- 43 44 (12)
- 51 52
- 61 62
- 71 72
- 81 82
- 13 14 (6)
- 21 22
- 31 32
- 43 44

- OUTDOOR UNIT TERMINAL
- INDOOR UNIT TERMINAL
- ◇ ELECTRIC HEATER TERMINAL

I-1918/a (3 of 4)  
BCVO-80,400.3.50

 THE COMPONENTS INCLUDED IN THESE BOXES ARE NOT SUPPLIED BY THE MANUFACTURER.  
 THE COMPONENTS INCLUDED IN THESE BOXES ARE STANDARD ACCESSORIES SUPPLIED BY THE MANUFACTURER.

# Control diagram

BCVO-80, 400.3.50 (4 of 4)

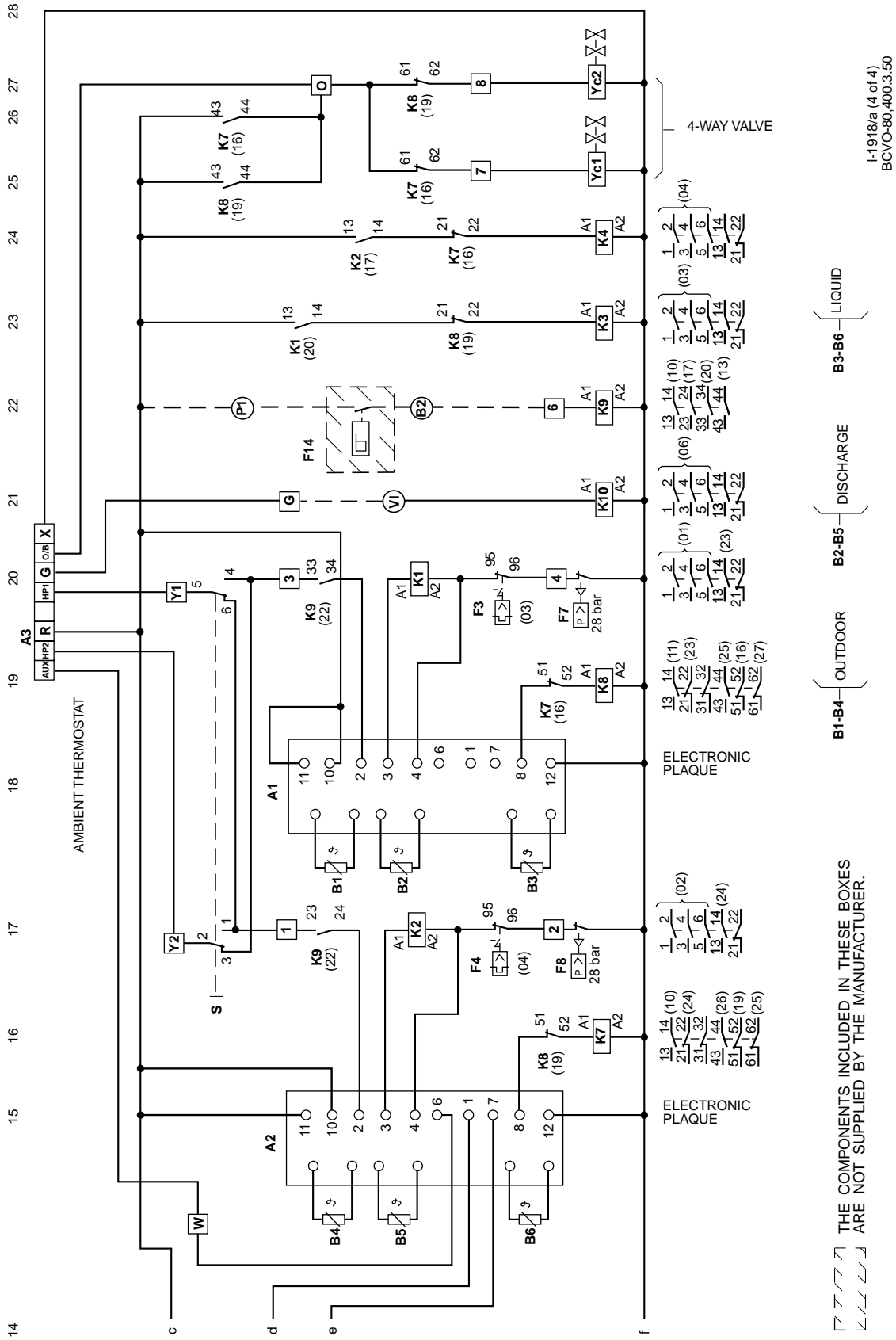

□ □ □ □ □ THE COMPONENTS INCLUDED IN THESE BOXES  
 L L L L L ARE NOT SUPPLIED BY THE MANUFACTURER.

I-1918/a (4 of 4)  
 BCVO-80, 400.3.50

All data subject to change without notice.

DECLARATION OF COMPLIANCE ON MACHINERY



MANUFACTURER: **CLIMA ROCA YORK, S.L.**

ADDRESSE: Paseo Espronceda, 278, 08.204 SABADELL

This machine complies with the basic demands of the EP Standards on machinery (Standard "EC" 89/392/CEE), including any modification of same.

APPLICATION OF THE MACHINE: AIR CONDITIONER/COOLING

TYPE: **BCVO/BCVI, CHI**

EC STANDARDS APPLIED: 89/392/EEC, 89/336/EEC

MATCHING STANDARDS APPLIED: EN60204-1, EN292-1, EN292-2, EN563, EN294, EN953, EN55014, EN60555-2, EN50082-1

INTERNATIONAL STANDARDS AND TECHNICAL SPECIFICATIONS APPLIED : EN ISO 9001, (Pr EN378)

PLACE: Sabadell, (España)

SIGNATURES:

A handwritten signature in black ink, appearing to read 'Román Larroda', is written over a horizontal line.

ROMÁN LARRODA  
QUALITY CONTROL MANAGER

